

Equipment	LIFTKET STAR MB 030/20 (500 kg)	
Width	Depth	Height
455	205	110
Weight	Approx. 29 Kg	
Wall Thickness	10mm	

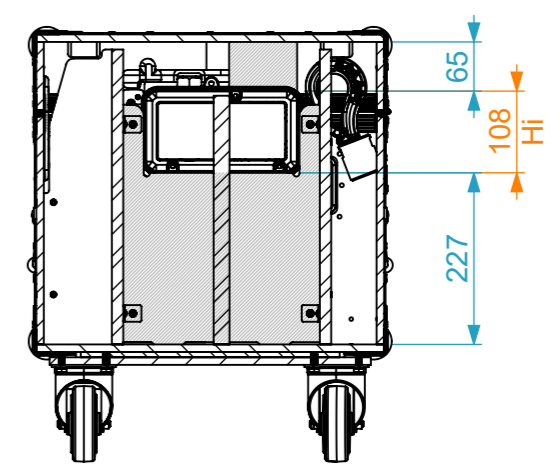
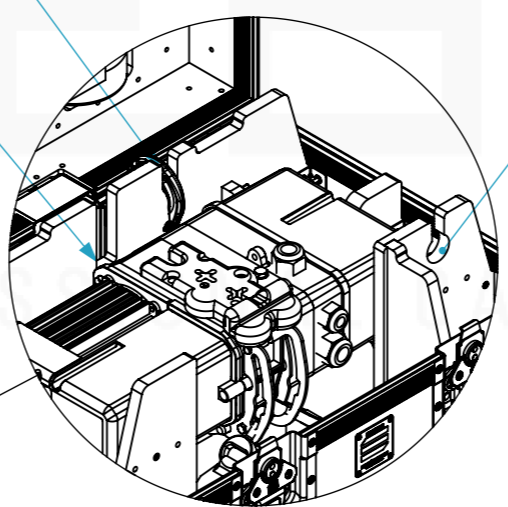
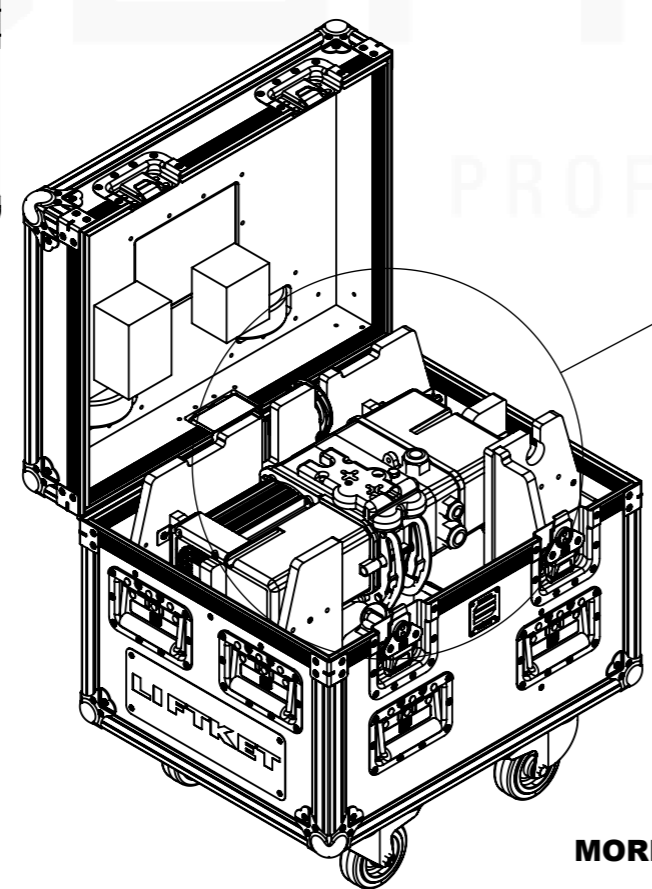
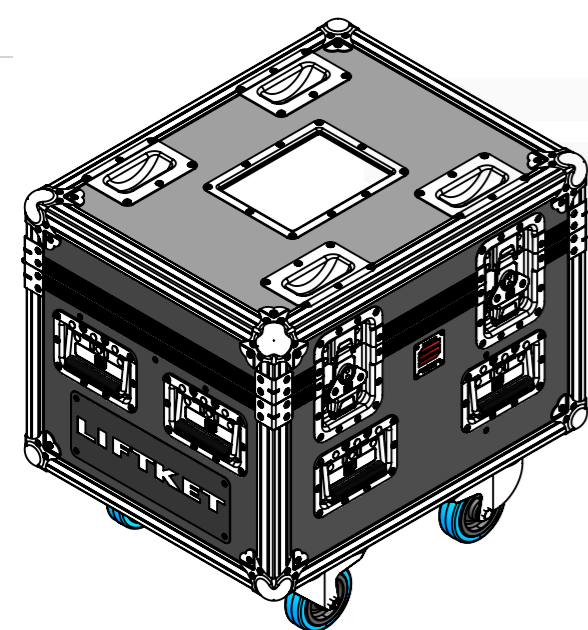
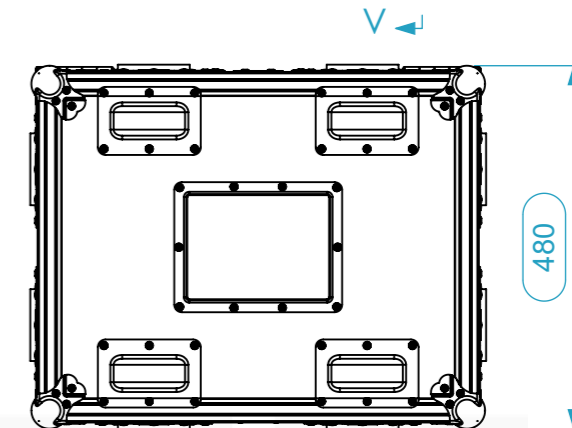
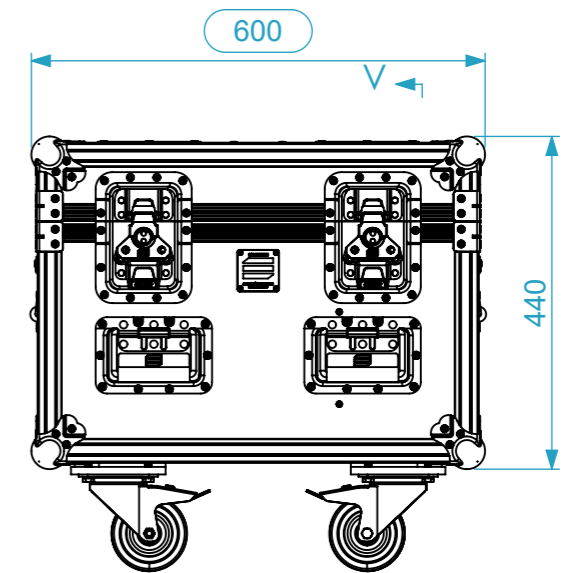
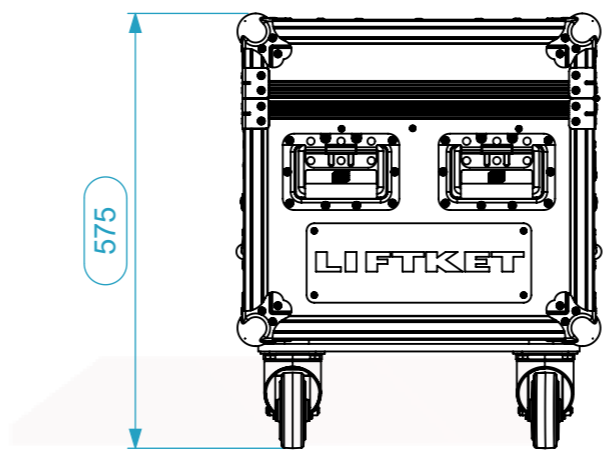
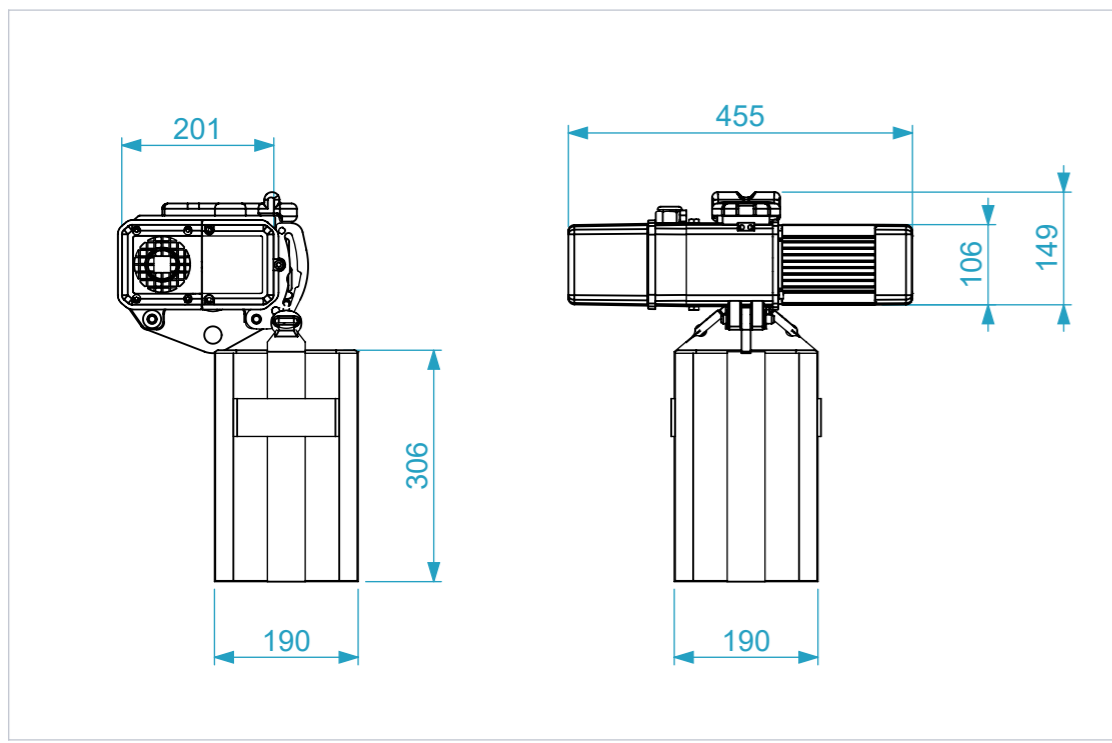

Cut-out for chain hook

Cut-out for chain

Cut-out for electrical cables

General External Dimensions	
W	Width
D	Depth
H	Height
Usable Inner Dimensions	
Wi	Inside Width
Di	Inside Depth
Hi	Inside Height
Wood Inner Dimensions	
WWi	Wood Inside Width
WDi	Wood Inside Depth
WHi	Wood Inside Height

MORE DETAILS IN THE NEXT PAGE

This drawing must not be copied or disclosed without consent of the owner

Drawn by	alexandre	Date	14/07/2020
Reference	LIFT.155		
Scale	1:10	units in mm	general tolerance 0.8mm
1st Angle projection	Flight case PRO, 1x LIFTKET STAR 500kg		



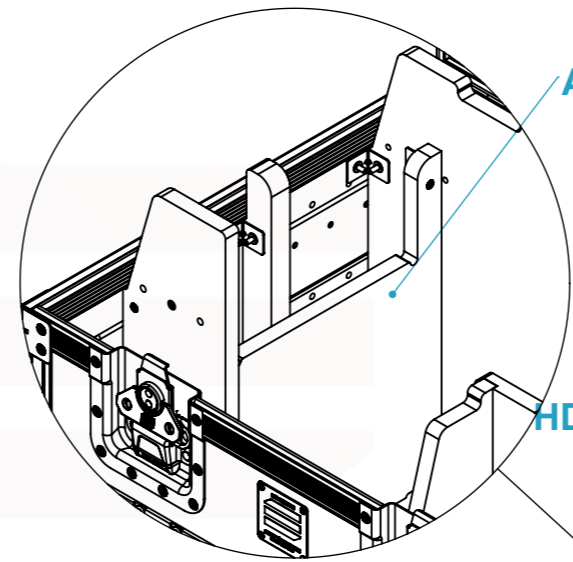
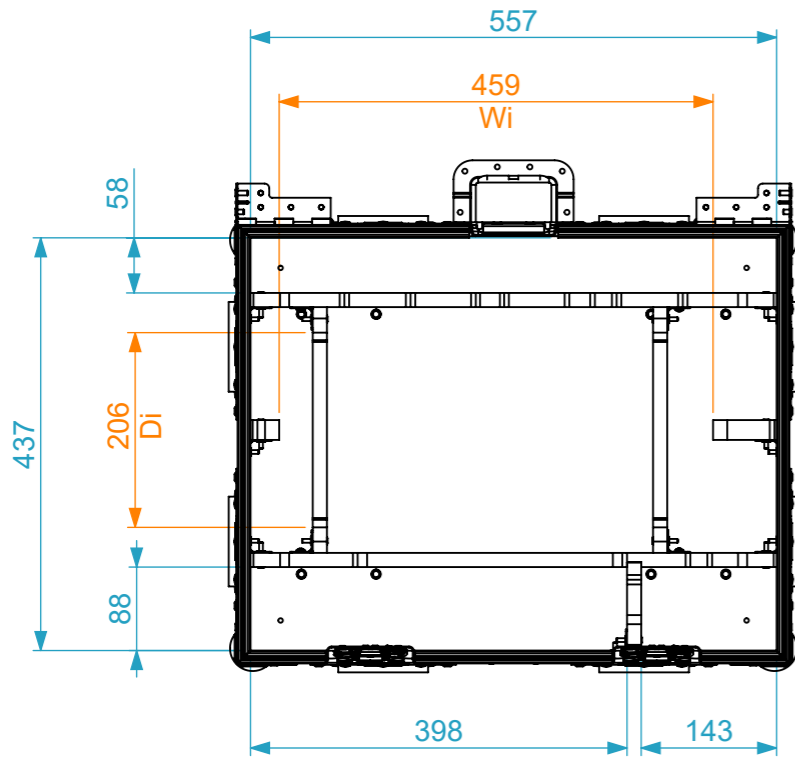

Adjustable divider

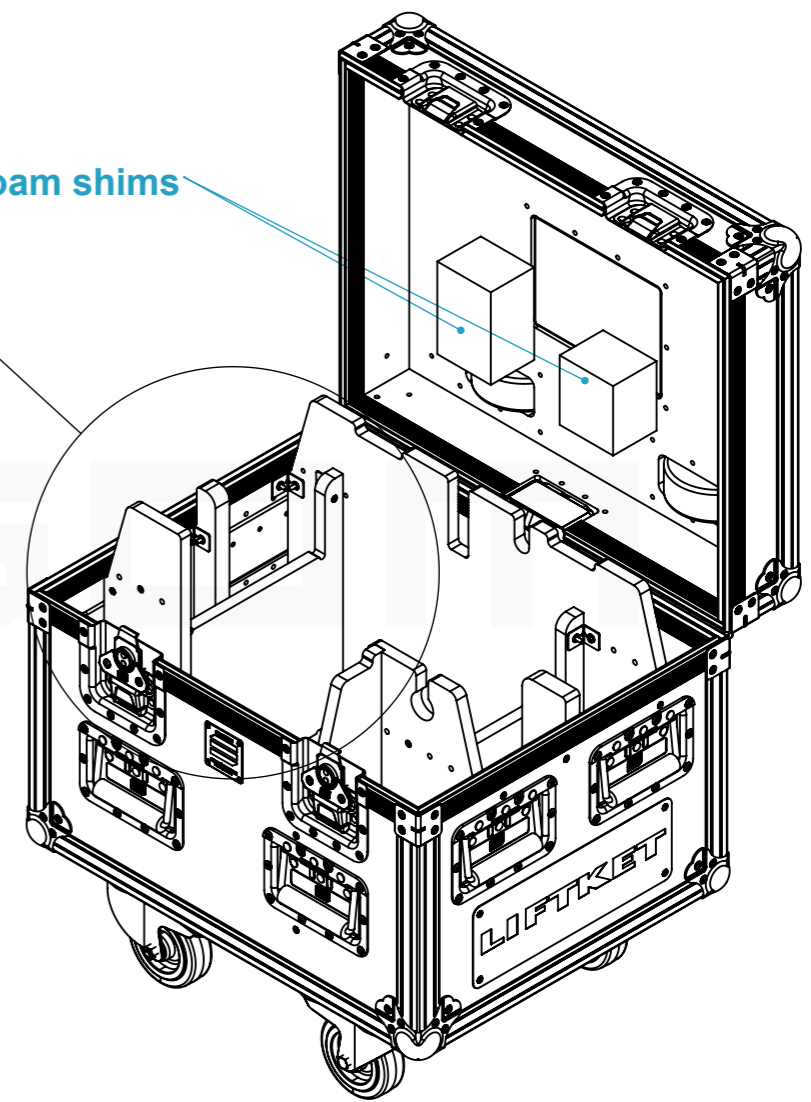

HD Foam shims

Compartments for hoist chain

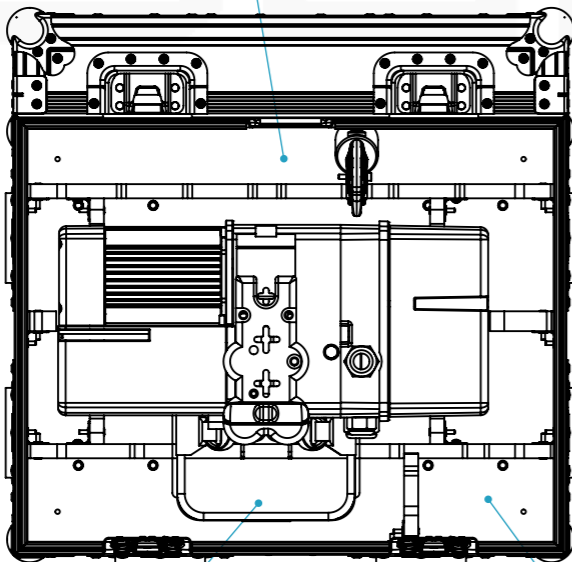

Compartment for the chain bag

Compartment for electrical cables and socket

PROFESSIONAL CASES

Drawn by	Name	Date
alexandre	alexandre	14/07/2020
Reference	LIFT.155	
Scale	units in mm	general tolerance
1:8	DO NOT SCALE	0.8mm
Flight case PRO, 1x LIFTKET STAR 500kg		



A3 This drawing must not be copied or disclosed without consent of the owner

