

<b>Equipment</b>	STAGEMAKER D8 SL5 DB + GLS	
<b>Width</b>	<b>Depth</b>	<b>Height</b>
519	282	180
<b>Weight</b>	Approx. 60 Kg	
<b>Wall Thickness</b>	10mm	

STAGEMAGER SL5

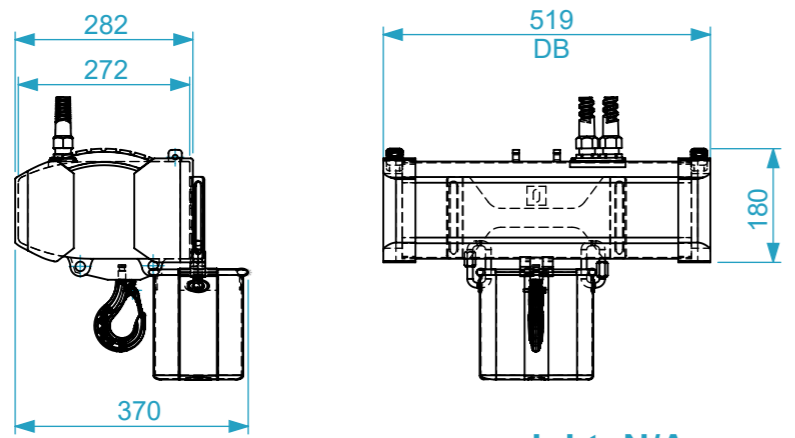

weight: N/A

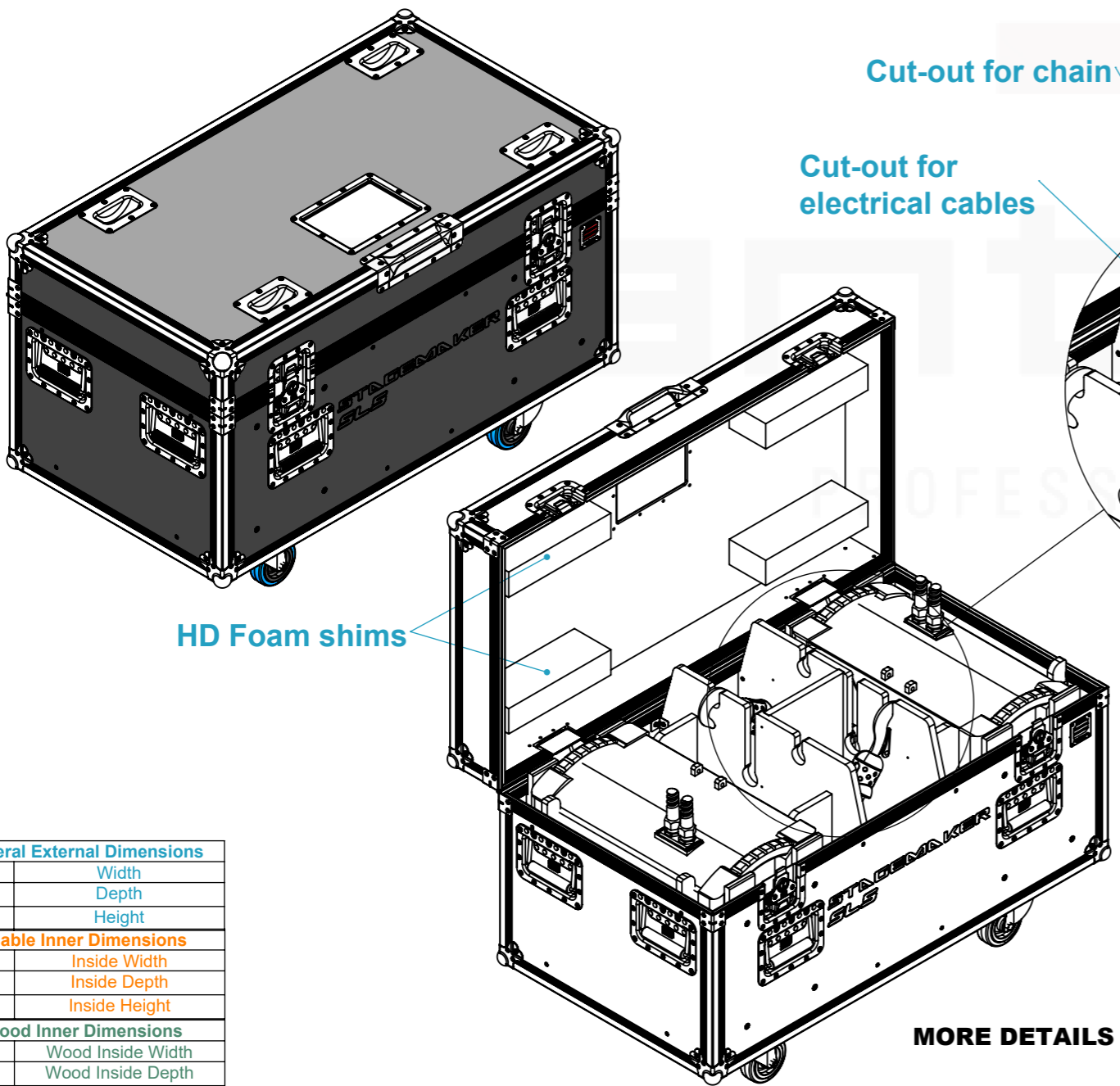
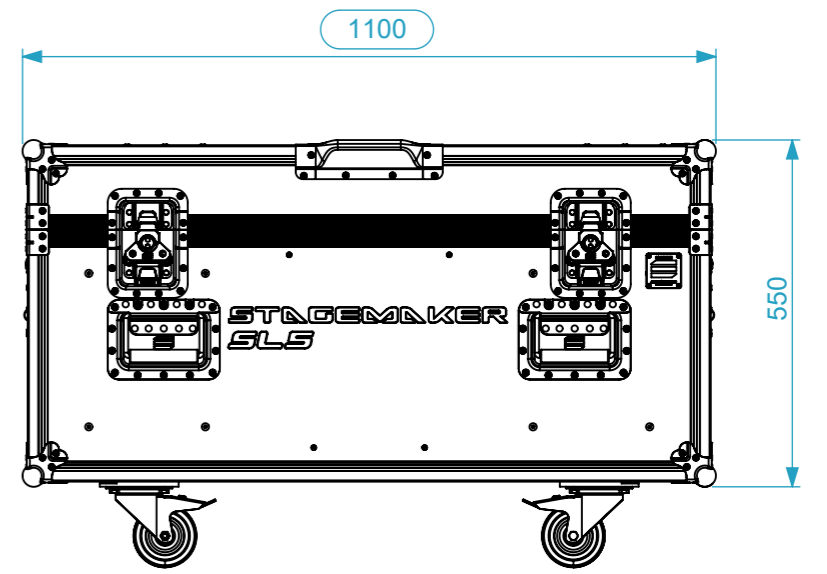
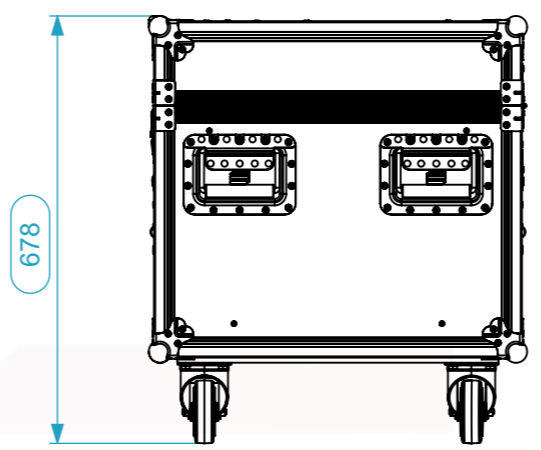

Cut-out for chain  
Cut-out for electrical cables  
Cut-out for chain hook

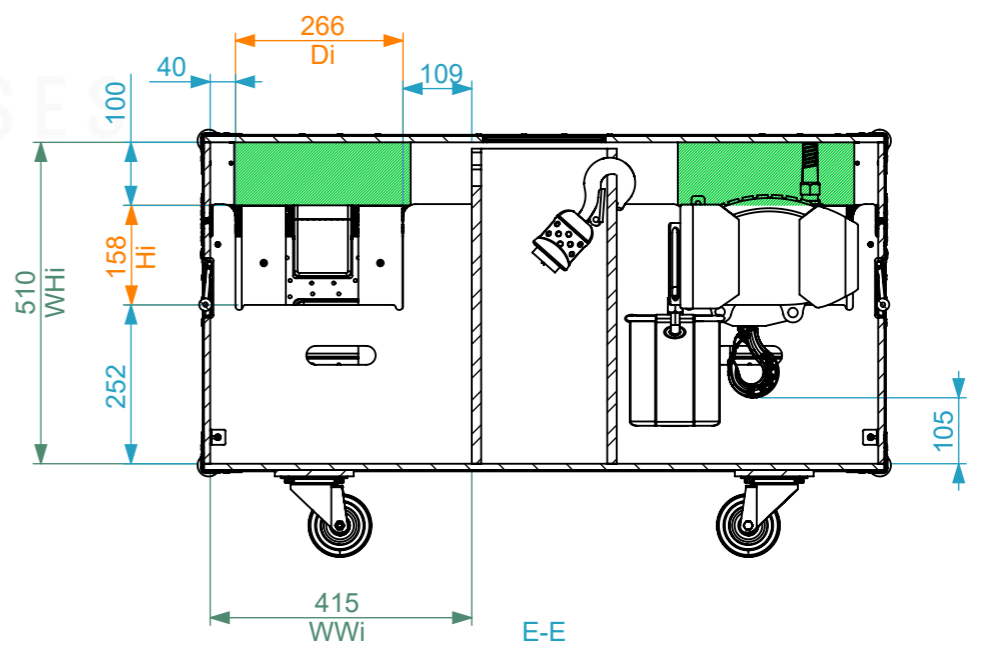
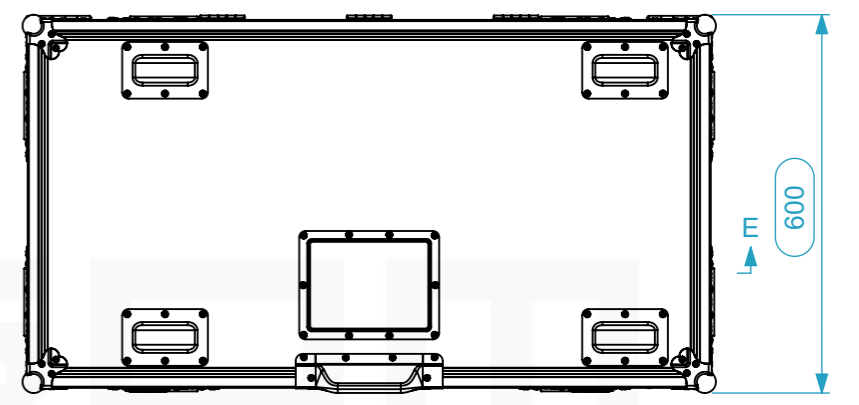
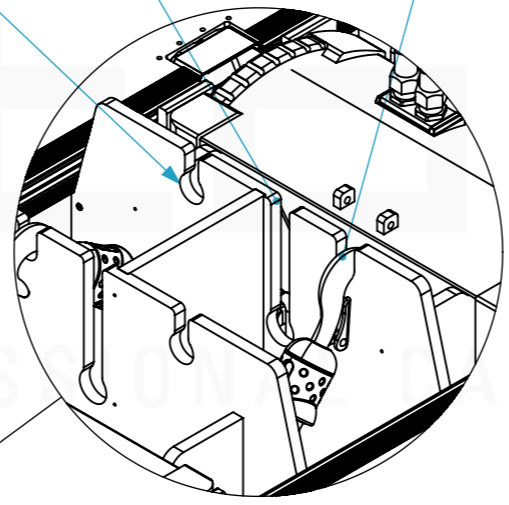

General External Dimensions	
W	Width
D	Depth
H	Height
Usable Inner Dimensions	
Wi	Inside Width
Di	Inside Depth
Hi	Inside Height
Wood Inner Dimensions	
WWi	Wood Inside Width
WDi	Wood Inside Depth
WHi	Wood Inside Height

MORE DETAILS IN THE NEXT PAGE

Name	Date
alexandre	11/02/2020
Reference	LIFT.149
Scale	1:12
units in mm	general tolerance 0.8mm
Flight case, 2x Verlinde Stagemaker D8 SL5	



This drawing must not be copied or disclosed without consent of the owner

1st Angle projection

A3

The flightcase is compatible STAGEMAKER SL5 Double Brake configuration.

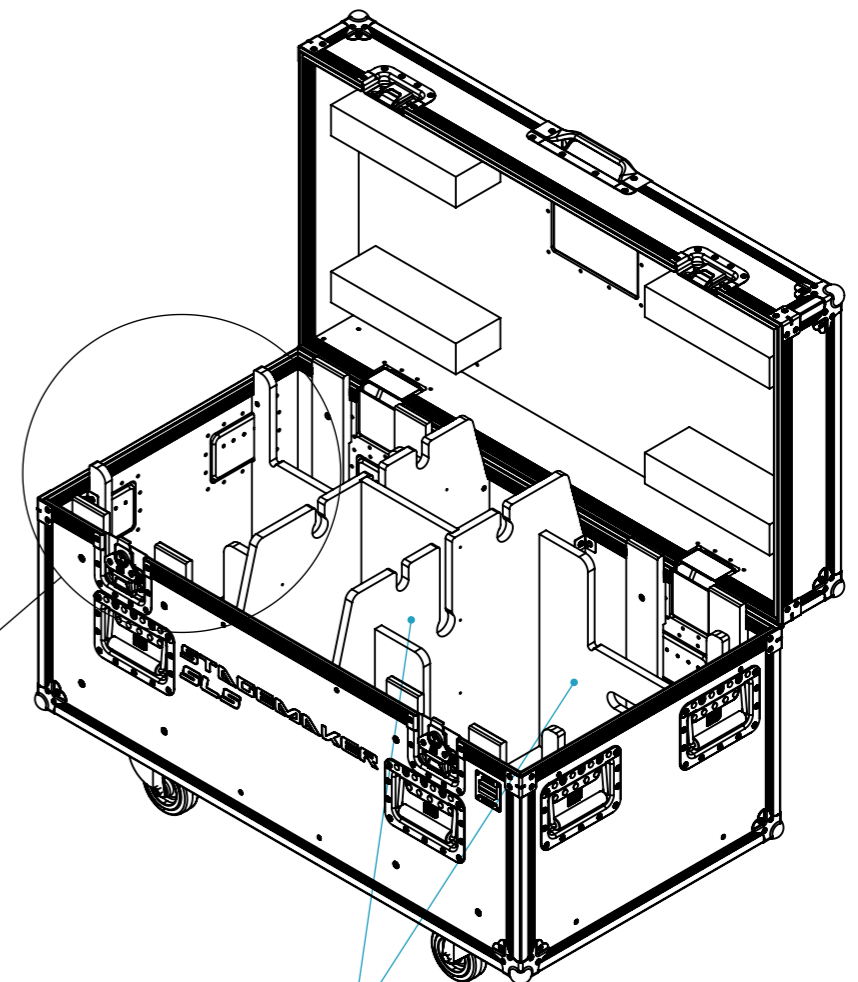
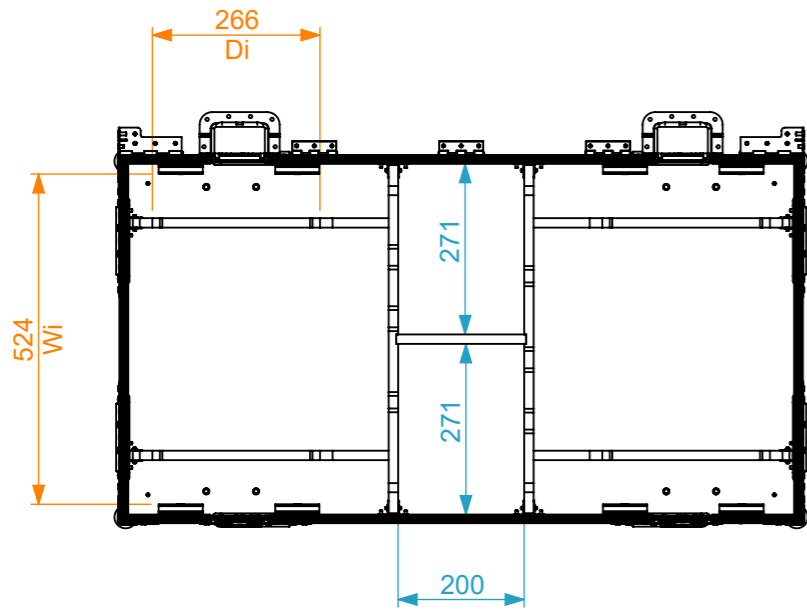

Plywood dividers

Compartment for the chain bag

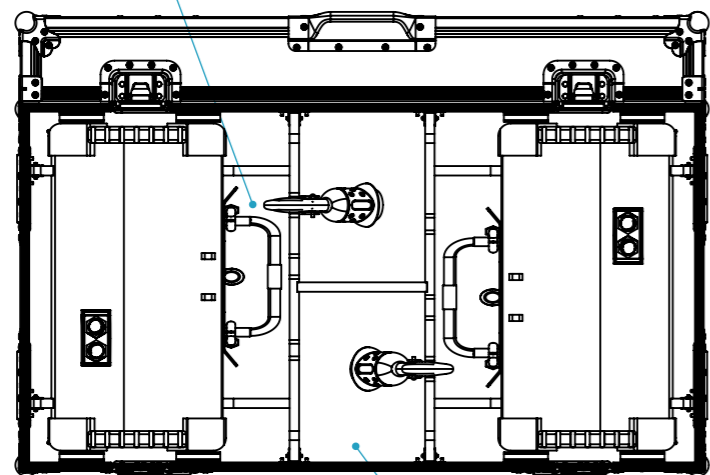

Compartment for hoist chain and electrical cables

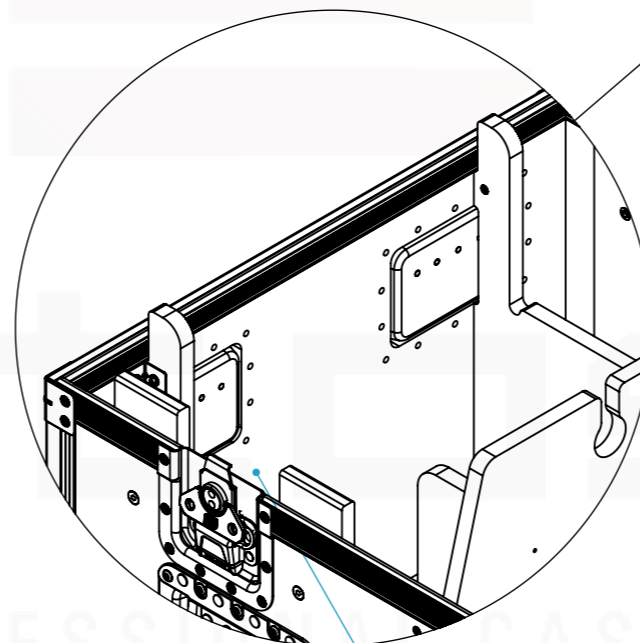

Gap for access to chain hoist handles

Drawn by	Name	Date
alexandre	alexandre	11/02/2020
Reference	LIFT.149	
Scale	units in mm	general tolerance
1:12	DO NOT SCALE	0.8mm
Flight case, 2x Verlinde Stagemaker D8 SL5		



This drawing must not be copied or disclosed without consent of the owner

1st Angle projection

A3