

Equipment	VICINAY ABK101-1004U	
Width	Depth	Height
266	387	164
Internal Dimensions		
Width	Depth	Height
1056	436	480
Weight	Approx. 47 Kg	
Wall Thickness	10mm	

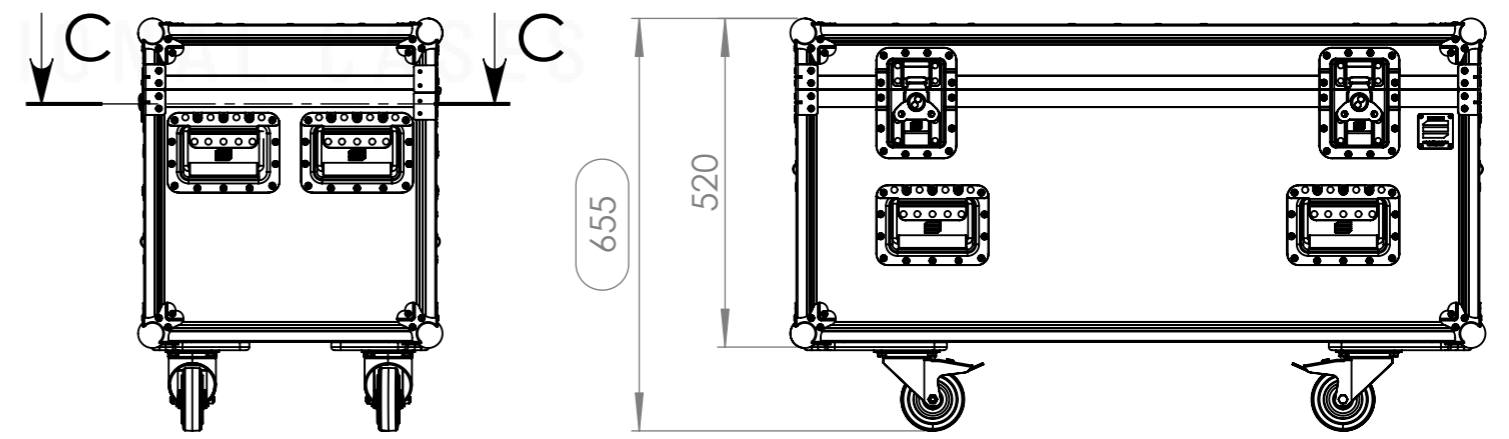
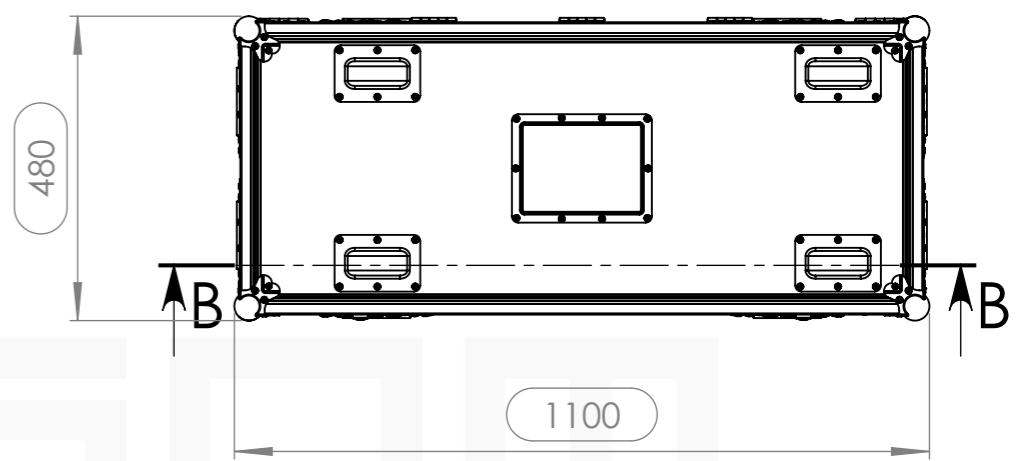
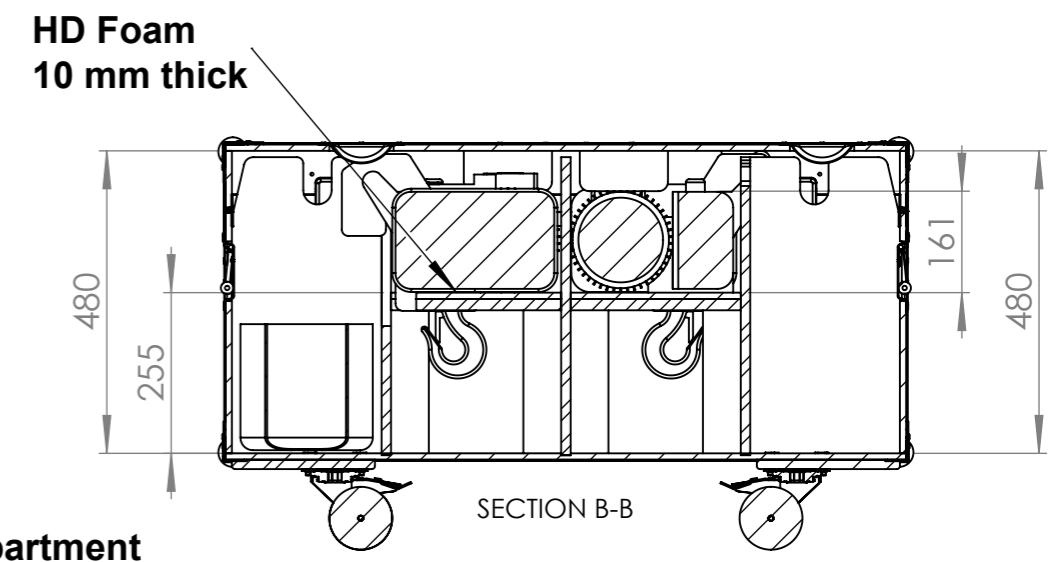
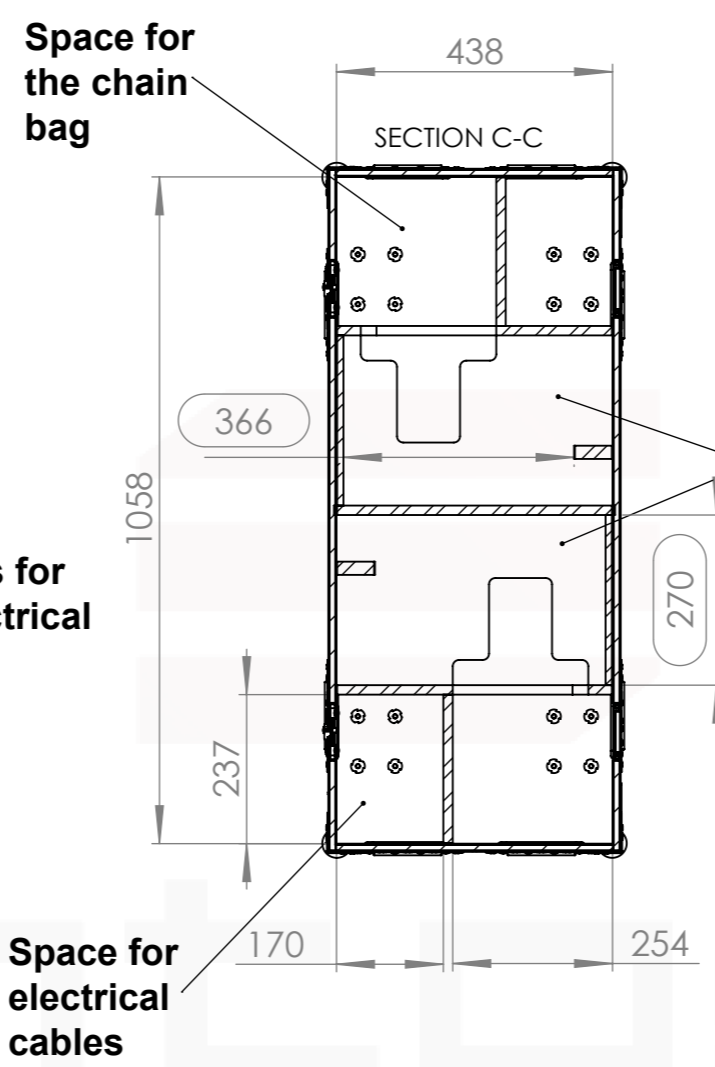
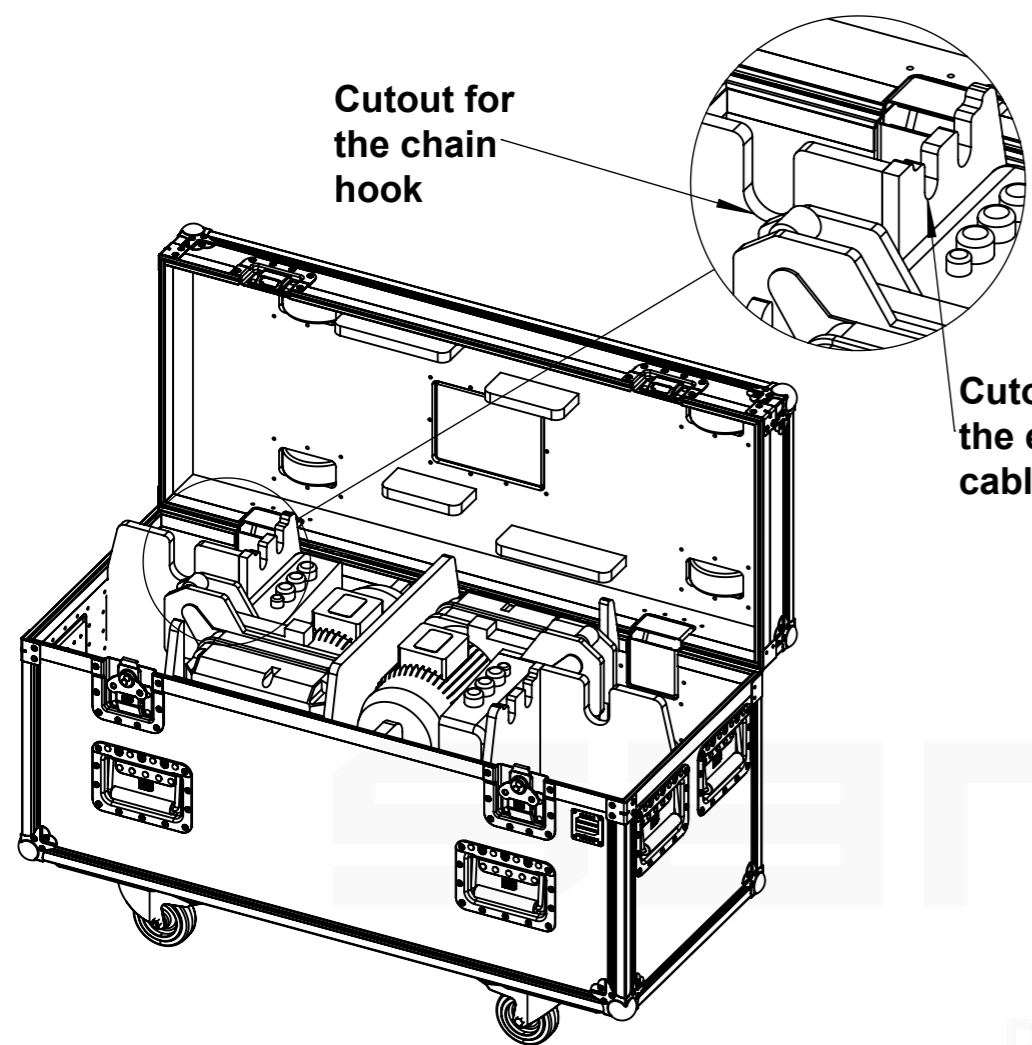

Hardware		
Qty	Ref.	Description
4	40403	Large corner bracket f. 35mm case angle
8	410429	Ball Corner large three-leg cranked 35 mm 9 holes
8	34085	Large, heavy duty, recessed sprung handle
1	88001D	Dish for 88001 Tour Label
1	CHAPA.1000	Identification Plate
2	172511COMP	Large AH butterfly with 'push-back', 14mm dish
2	270836	Large lidstay cranked / hinge
2	RODA.100T	Swivel castor Ø100mm with brake
2	RODA.100	Swivel castor Ø100 mm
4	38083	Castor dish deep zinc plated
2	DCR110	Combination of Hinge and 2 Corner Braces
3	2602	Medium duty butt hinge z./p.

This drawing must not be copied or disclosed without consent of the owner

Drawn by	alexandre	Date	15/03/2017
Reference	LIFT.125		
Scale	1:12	units in mm	DO NOT SCALE
		general tolerance	0.8mm
FLIGHTCASE, 2X VICINAY ABK101-1004U IT, RODAS			

