

Interior dimensions		
Width	Depth	Height
1030	185	756
Weight	Approx. 29 Kg	
Wall Thickness	9mm	

REVISIONS				
ZONE	REV.	DESCRIPTION	DATE	APPROVED
	0	Final Drawing	15/01/2016	Carlos Rodrigues

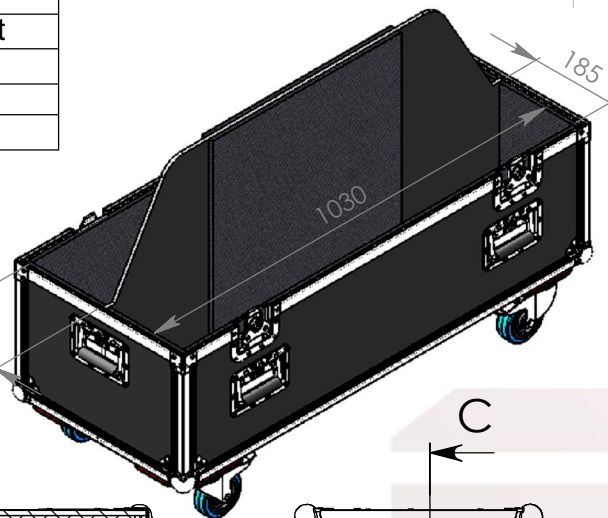

SECTION C-C
SCALE 1 : 10

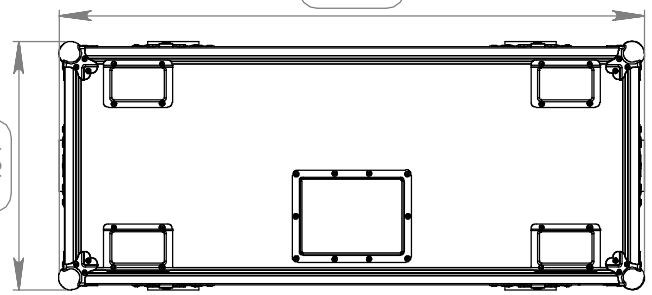
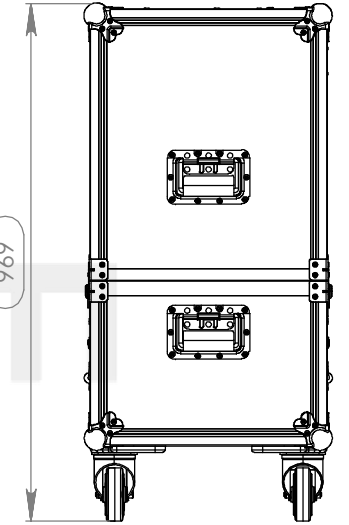
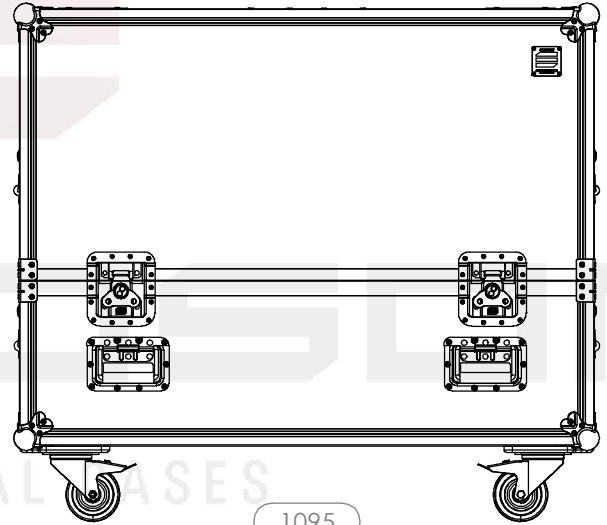
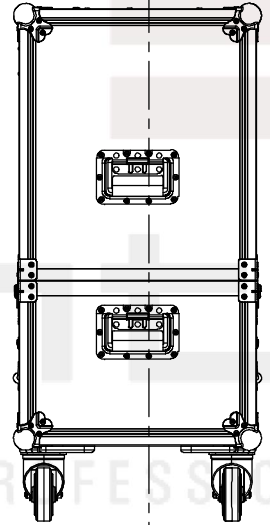
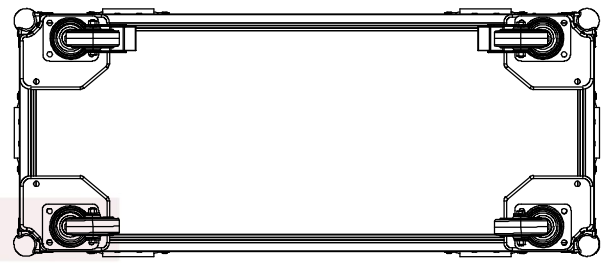
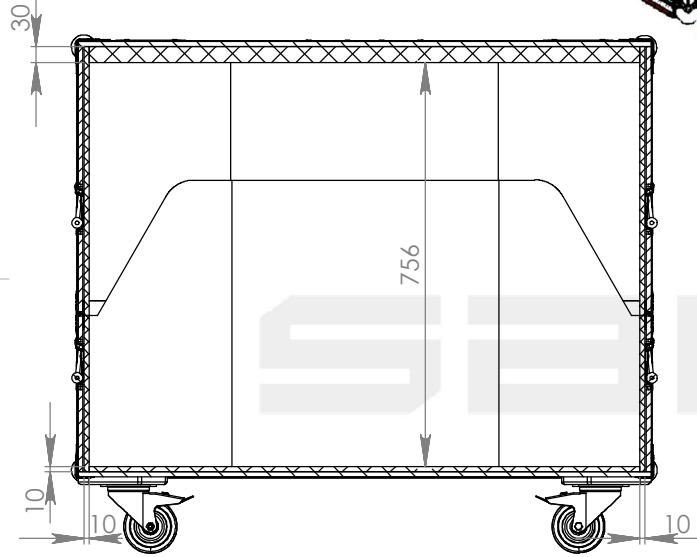

Hardware		
Qty	Ref.	Description
8	410429	Heavy Duty Ball Corner
8	40403	Large corner bracket f. 35mm case angle
4	172531	Large butterfly V3 with 'push-back' function
8	34082	Recessed sprung handle medium model
1	88001D	Dish for 88001 Tour Label
1	CHAPA.1000	Identification Plate
2	RODA.100T	Swivel castor Ø100mm with brake
2	RODA.100	Swivel castor Ø100 mm
4	38082	Castor dish deep zinc plated

This drawing must not be copied or disclosed without consent of the owner

Drawn by	Name	Date
Telmo Santos	Telmo Santos	18/01/2016
Reference	LED.320R	
Scale	units in mm	general tolerance
1:5	DO NOT SCALE	0.8mm
1st Angle projection	ECRAN DE LED 1024X200X780MM., RODAS	

