

Internal Dimensions		
Width	Depth	Height
856	656	560
Weight	Approx. 32 Kg	
Wall Thickness		10mm

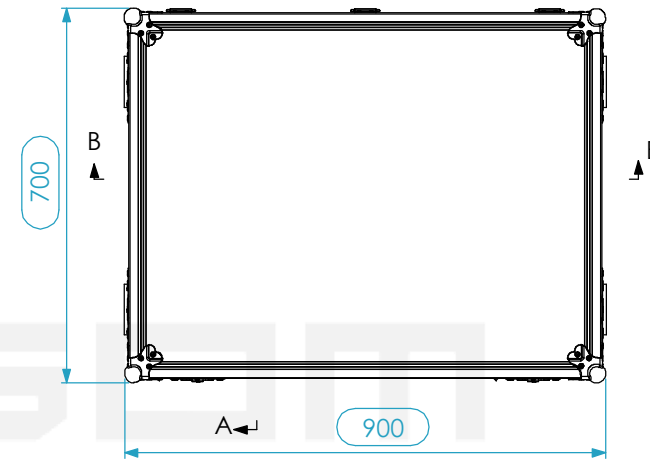

SECTION A-A

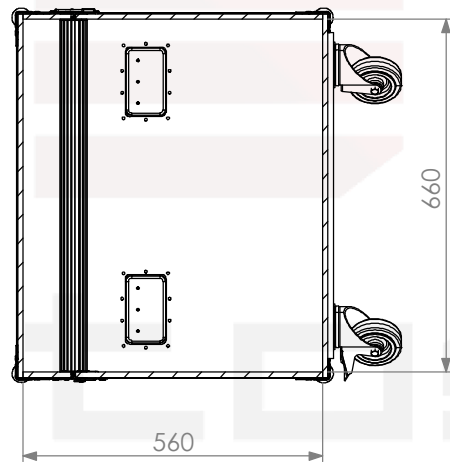
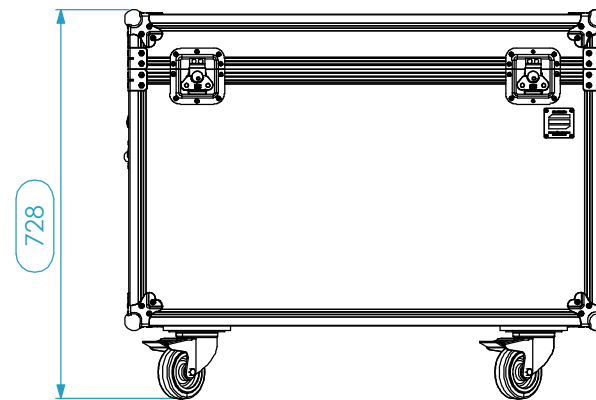
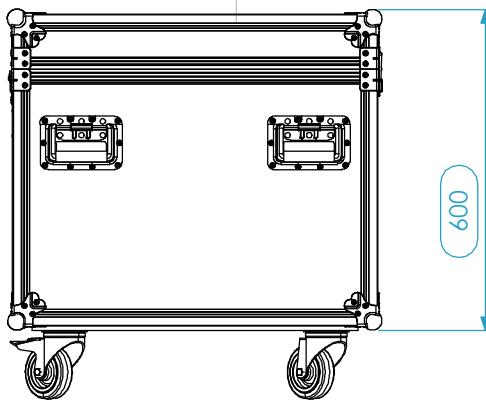
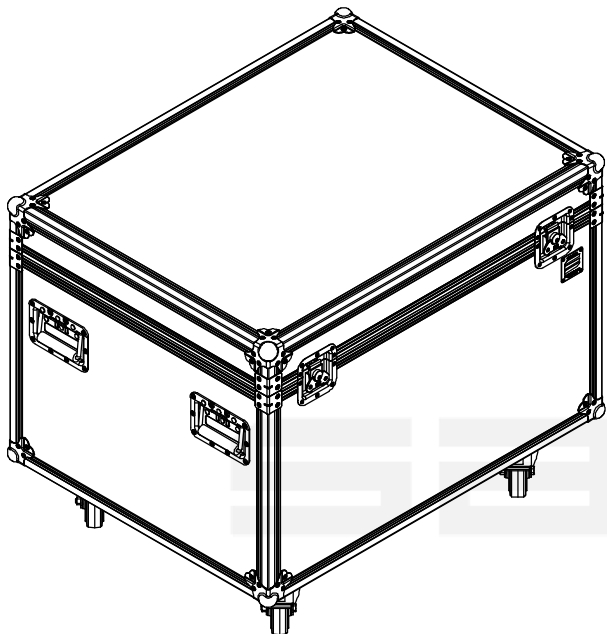
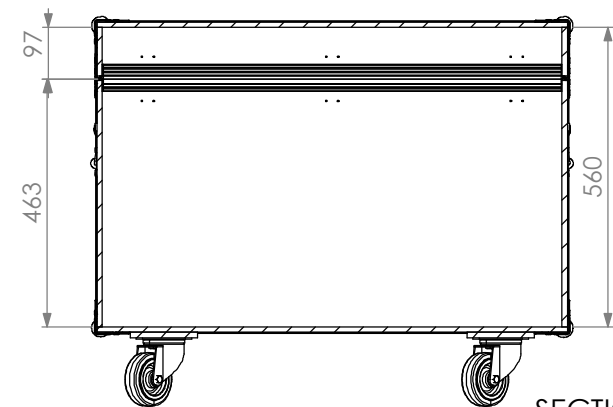

SECTION B-B

Hardware		
Qty	Ref.	Description
8	410429	Heavy Duty Ball Corner
8	40403	Large corner bracket f. 35mm case angle
2	RODA.100T	Swivel castor Ø100mm with brake
2	RODA.100	Swivel castor Ø100 mm
4	34082	Recessed Sprung Handle Medium
2	17290S	Key lockable medium Butterfly special
3	2524	Heavy Duty Strut Hinge
2	R1.070	Whells Feet for 700mm cases

This drawing must not be copied or disclosed without consent of the owner



Scale	1:10
units in mm	DO NOT SCALE
general tolerance	0.8mm
FC L1AA.756X436X440	

