

Internal Dimensions		
Width	Depth	Height
556	506	600
Weight	Approx. 24 Kg	
Wall Thickness		10mm

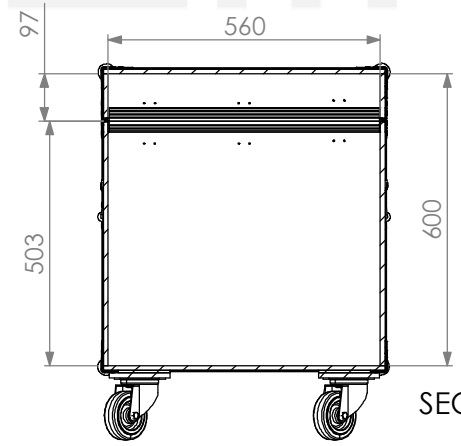
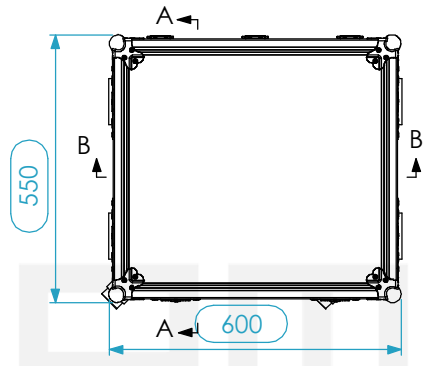
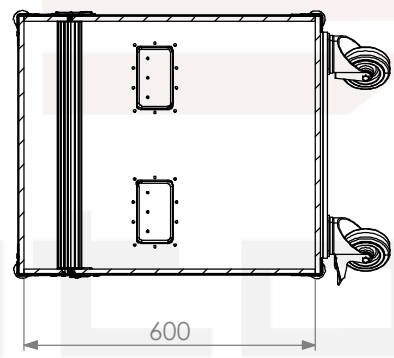
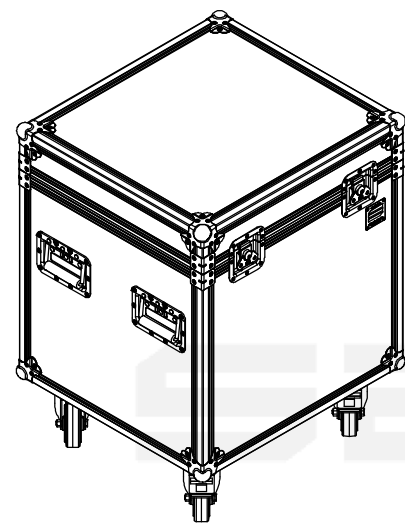
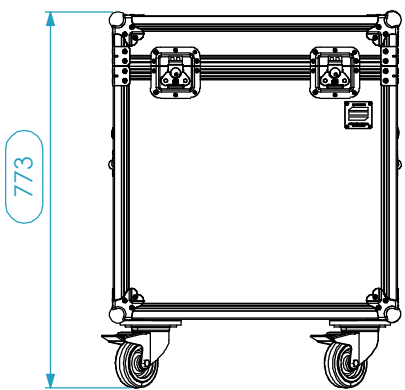
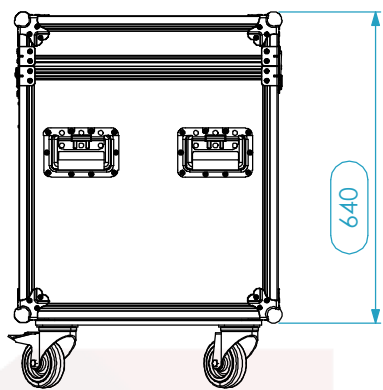

SECTION A-A

SECTION B-B

Hardware		
Qty	Ref.	Description
8	410429	Heavy Duty Ball Corner
8	40403	Large corner bracket f. 35mm case angle
2	RODA.100T	Swivel castor Ø100mm with brake
2	RODA.100	Swivel castor Ø100 mm
4	34082	Recessed Sprung Handle Medium
2	17290S	Key lockable medium Butterfly special
3	2524	Heavy Duty Strut Hinge
2	R1A.055	Whells Feet 550mm

PROFESSIONAL CASES

This drawing must not be copied or disclosed without consent of the owner

Scale	1:11	units in mm	general tolerance 0.8mm
Reference	L1AAR.0605564		
FC	L1AA.556X506X600		

