

### Interior dimensions

Width	Depth	Height
1197	370	145
Weight	Approx. 31 Kg	
Wall Thickness	7mm	

### REVISIONS

ZONE	REV.	DESCRIPTION	DATE	APPROVED
-	0	Final Drawing	10-06-2016	Ezequiel Cambao

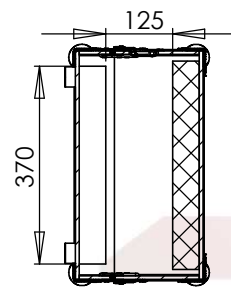

SEÇÃO F-F

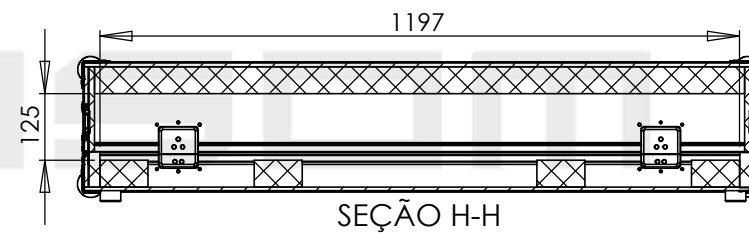
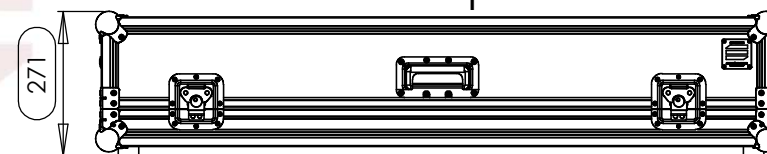
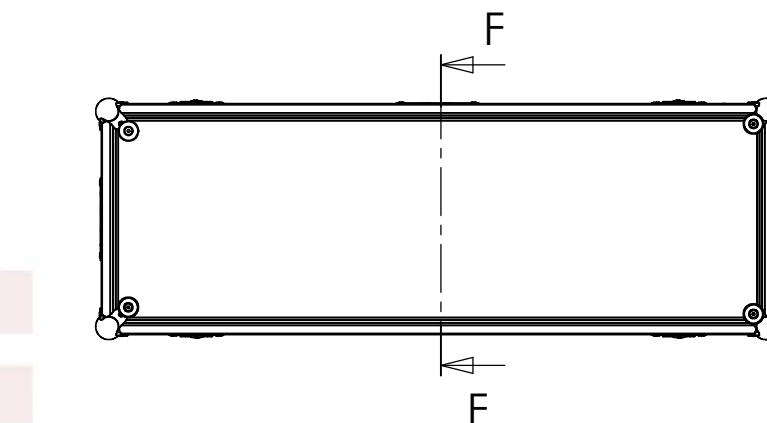
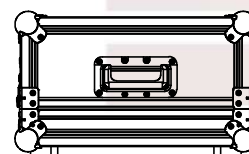

SEÇÃO H-H

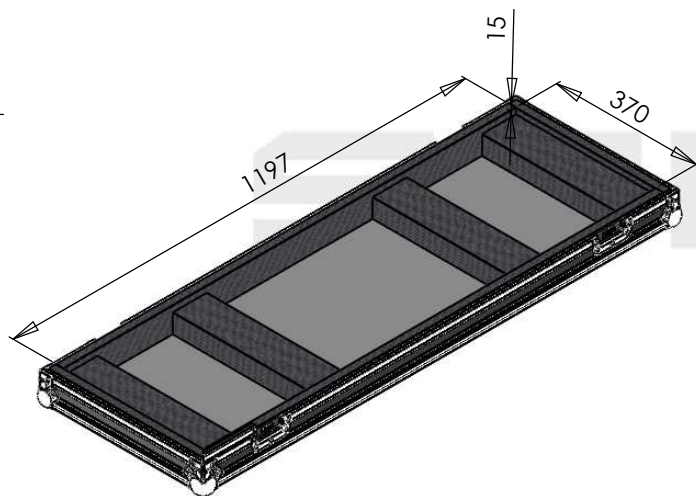
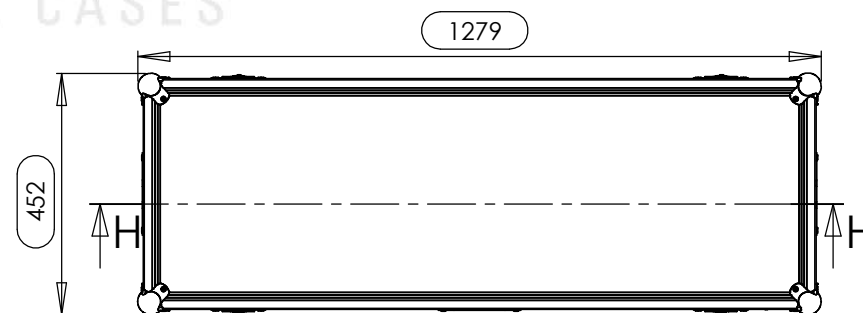

### Hardware

Qty	Ref.	Description
4	17290S	Key lockable medium Butterfly special
8	4120	Heavy duty ball corner, zinc plated
8	40403	Large corner bracket f. 35mm case angle
4	4909	38 mm rubber foot black with steel insert. Height: 20 mm.
3	340822	Recessed sprung handle - Small
1	CHAPA.1000	Identification Plate

This drawing must not be copied or disclosed without consent of the owner



Scale: 1:10  
UNITS IN mm DO NOT SCALE  
 general tolerance: 0.8mm

KEYBRD2.102  
 FLIGHTCASE TG. KORG P33X 76K

