

Internal Dimensions		
Width	Depth	Height
1363	483	203
Weight	Approx. 18.27 Kg	
Wall Thickness	10mm	

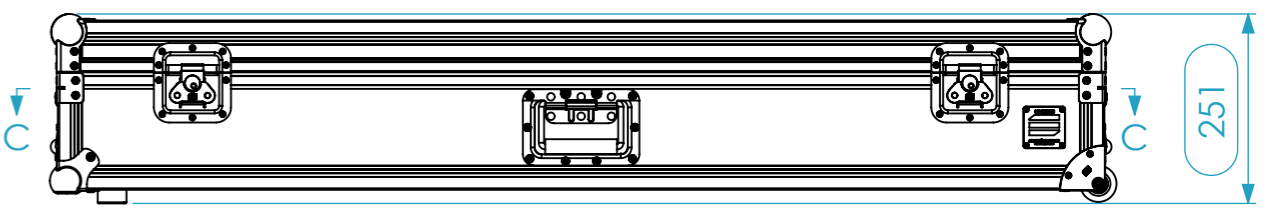

INTERIOR FOAM CAN BE ADJUSTED ACCORDING TO EQUIPMENT:

MAX.

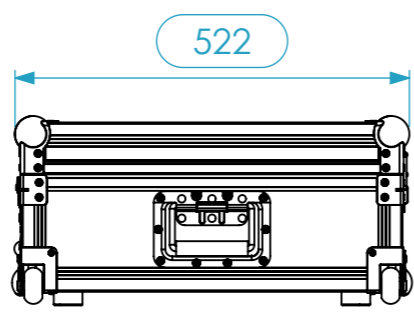
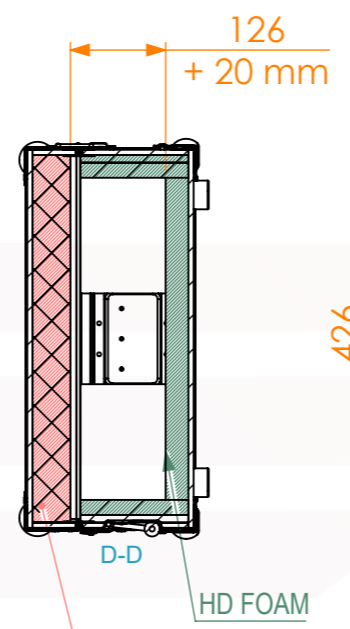
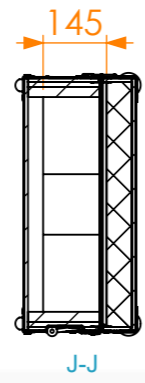
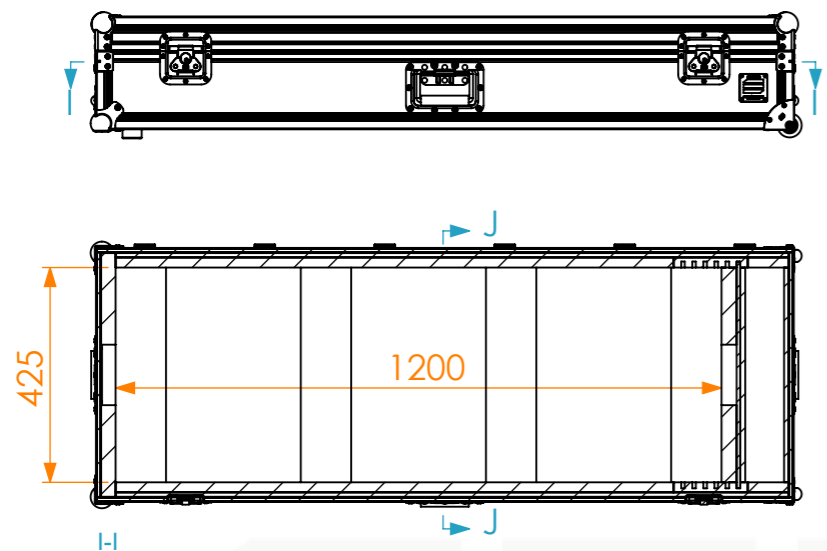

Pressing Eggbox Foam 50 mm thick

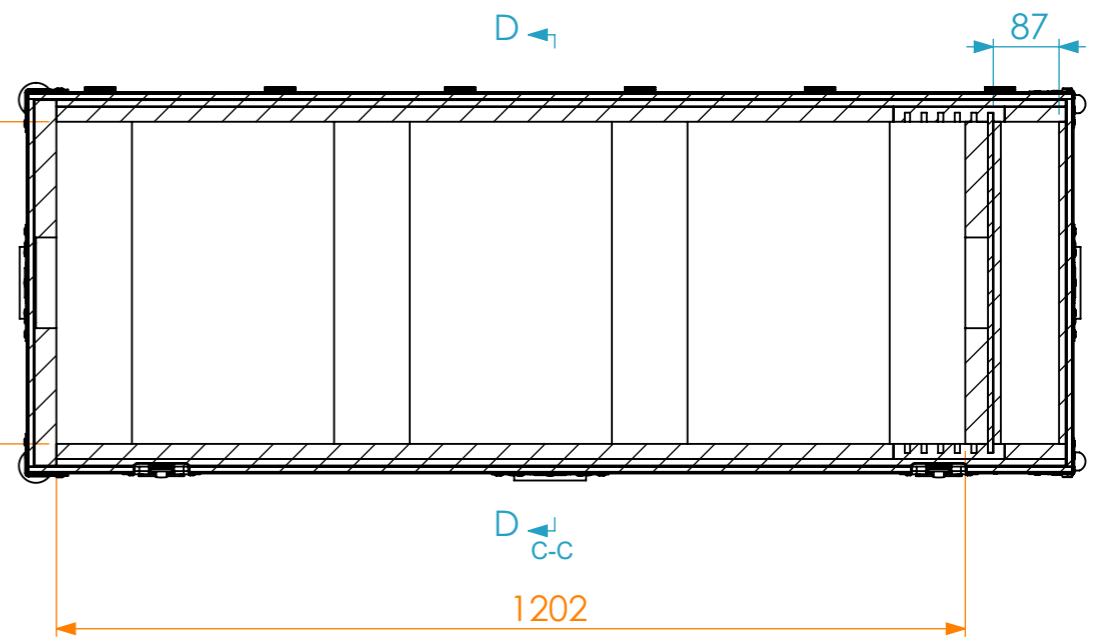

MIN.

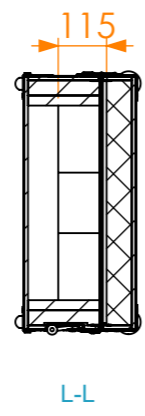
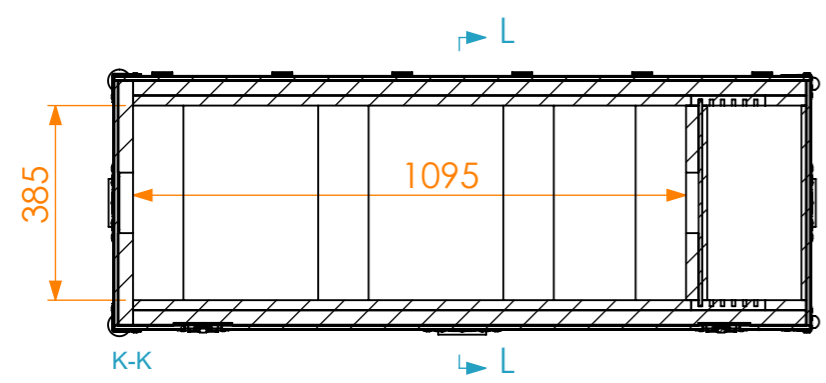

Equipment Dimensions			
	Width	Depth	Height
Min.	1097	386	96
Max.	1202	426	126

General External Dimensions		Usable Inner Dimensions	
W	Width	Wi	Inside Width
D	Depth	Di	Inside Depth
H	Height	Hi	Inside Height

Name	Date	
Drawn by	CarlaSilva	06/11/2018
Reference	KEY.140	
Scale	1:10	units in mm
	DO NOT SCALE	general tolerance 0.8mm
1st Angle projection	FC STANDARD, KEYBOARD	



This drawing must not be copied or disclosed without consent of the owner

A3