

Interior dimensions		
Width	Depth	Height
19"	600	10 uni
Weight	Approx. 25 Kg	
Wall Thickness		10mm

REVISIONS				
ZONE	REV.	DESCRIPTION	DATE	APPROVED
-	-	Final Drawing	21/07/2014	Daniel Lopes

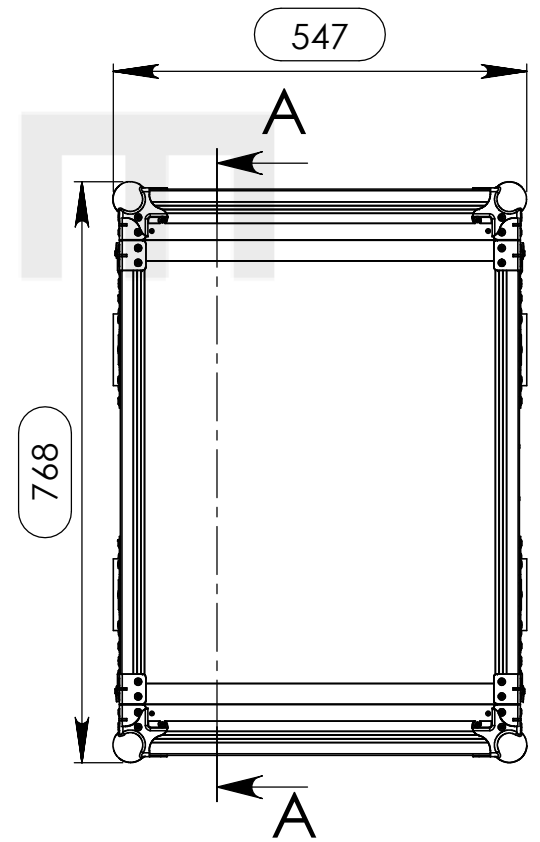
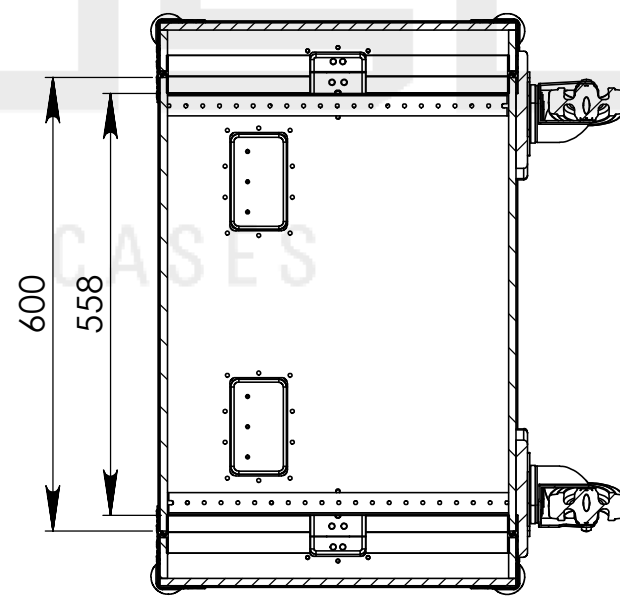
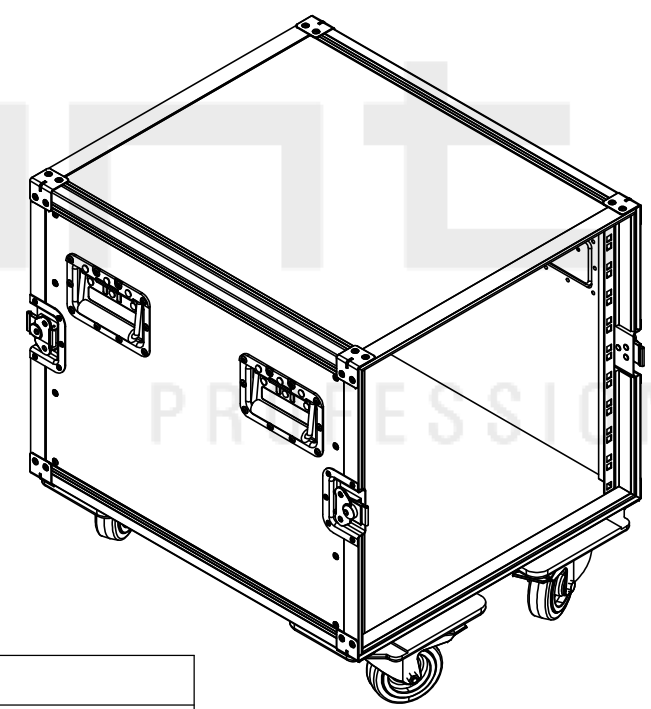
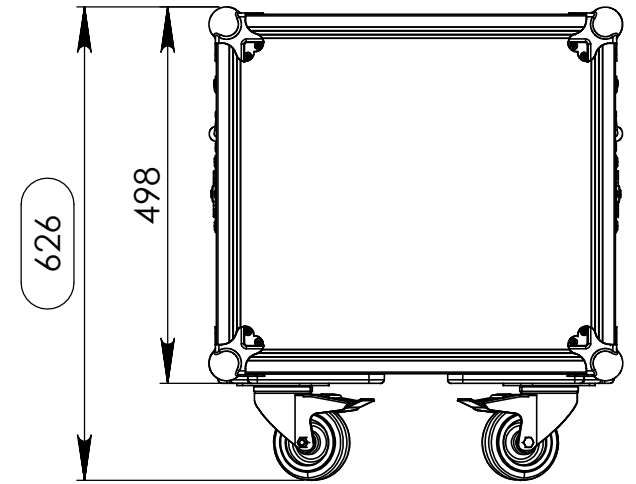
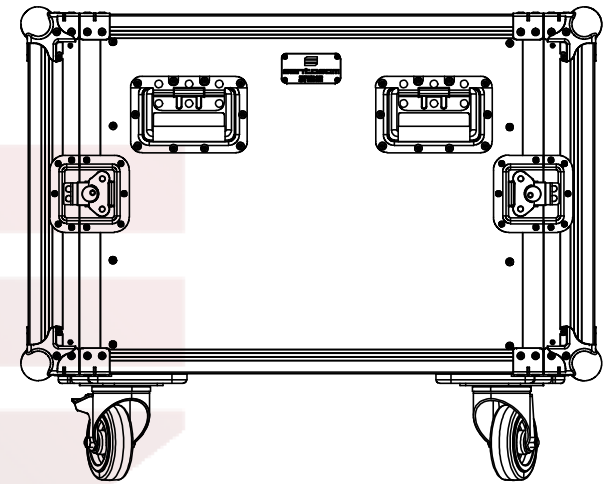
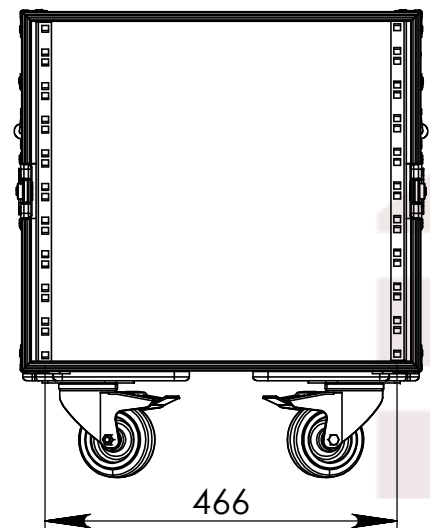
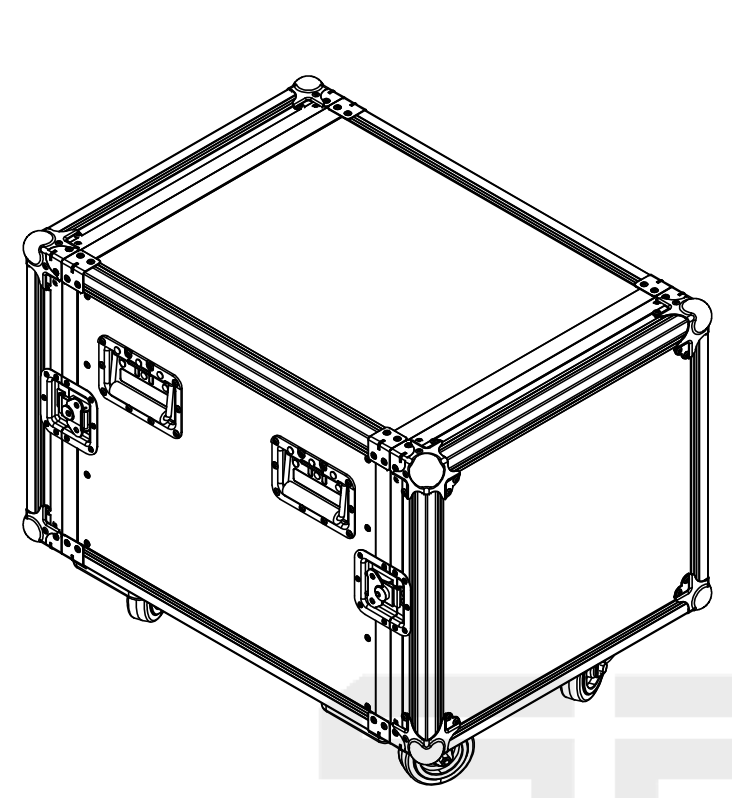

Hardware		
Qty	Ref.	Description
16	40403	Large corner bracket f. 35mm case angle
8	410429	Heavy Duty Ball Corner
1	CHAPA.1000	Identification Plate
4	17290S	Key lockable medium Butterfly special
4	34082	Recessed sprung handle medium model
2	RODAS.1001	Castor plate wood black
2	RODA.100T	Swivel castor Ø100mm with brake
2	RODA.100	Swivel castor Ø100 mm

SECTION A-A

This drawing must not be copied or disclosed without consent of the owner

Drawn by	Name	Date
DanielLopes	DanielLopes	21-07-2014
Reference	K2T.1060R	
Scale	units in mm	general tolerance
1:10	DO NOT SCALE	0.8mm
1st Angle projection	RACK 19" 2 TAMPAS 10U 600 PROF., RODAS	

