

### Interior dimensions

Width	Depth	Height
19"	800	5Un
Weight	Approx. 32 Kg	
Wall Thickness	10mm	

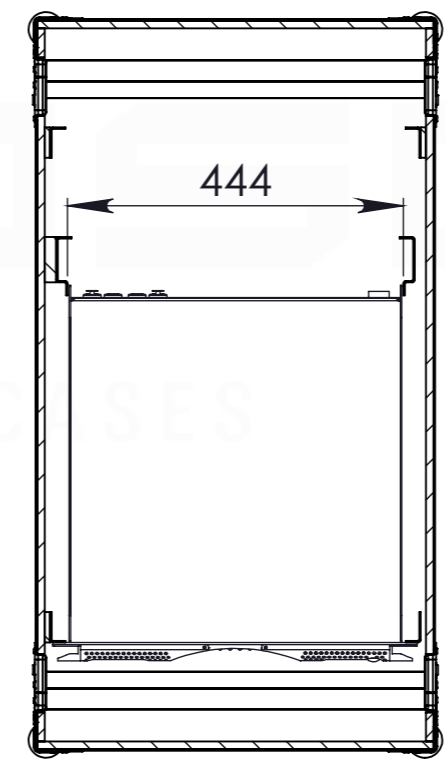

SECTION L-L

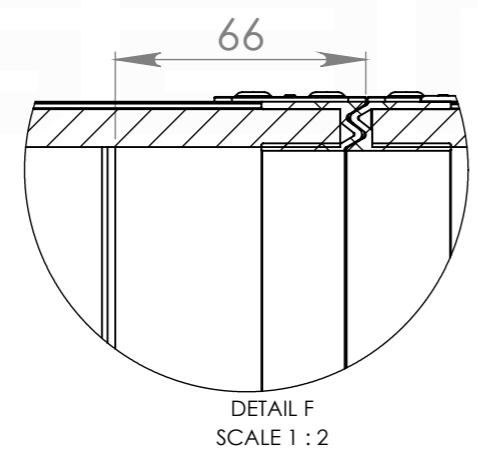
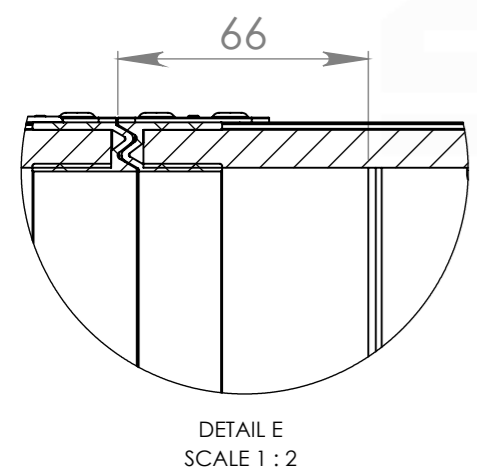
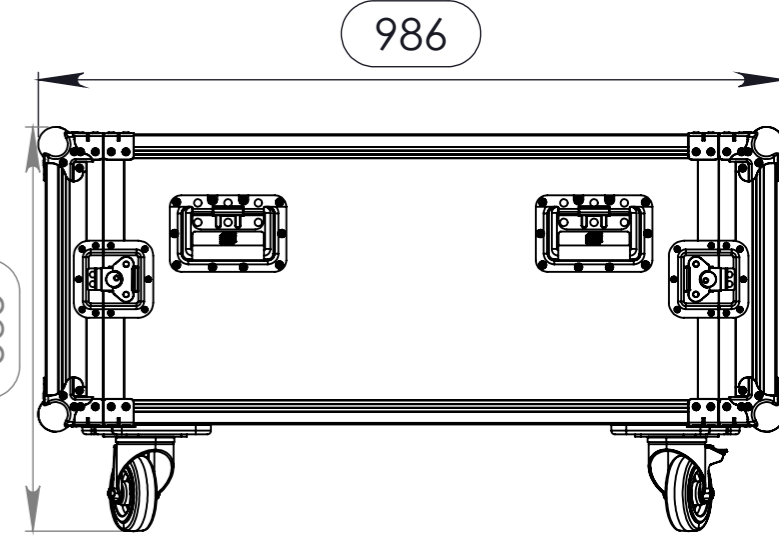
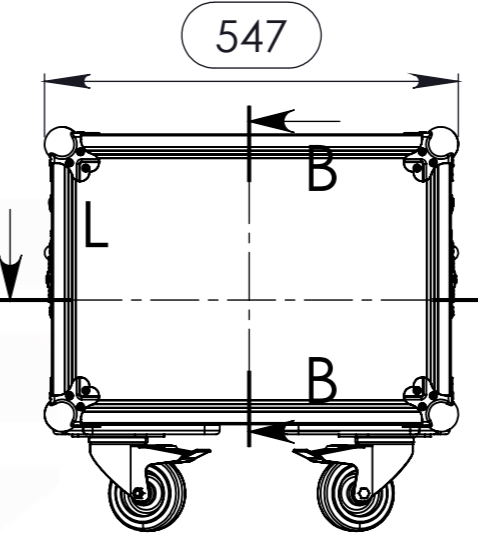
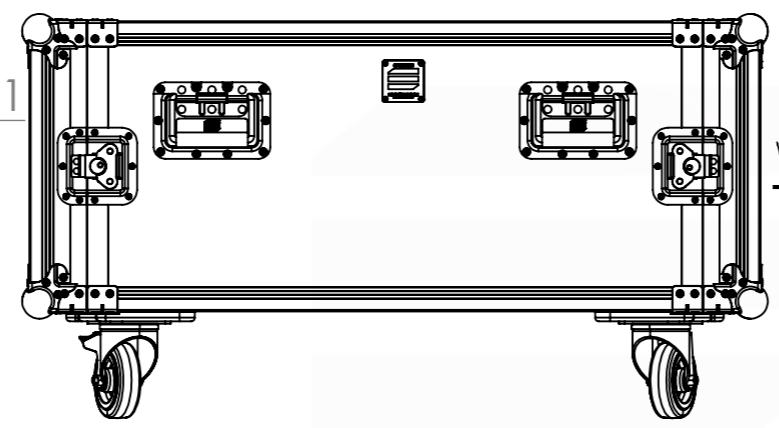
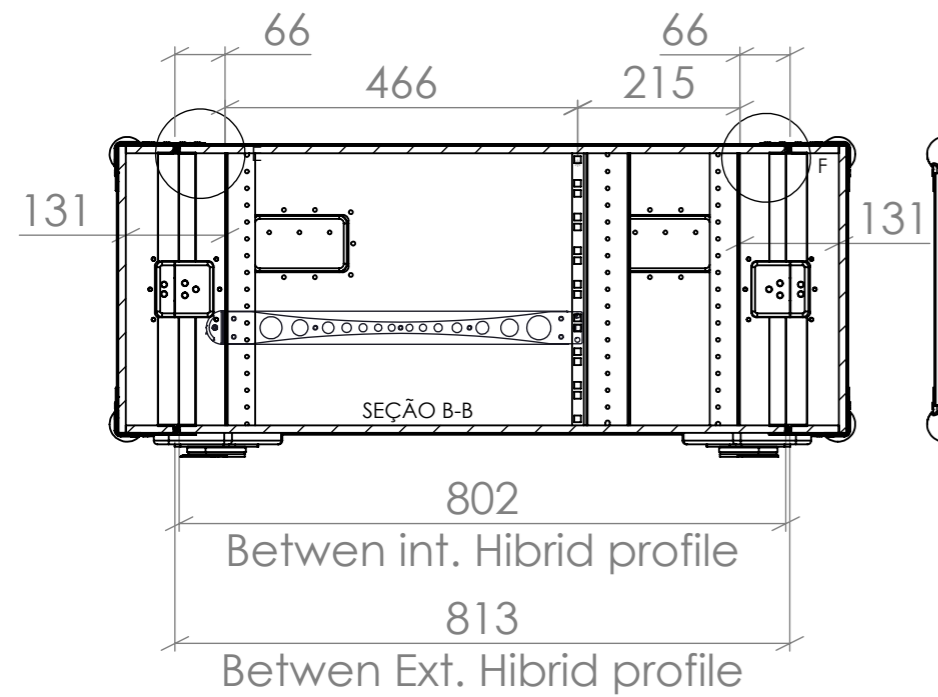
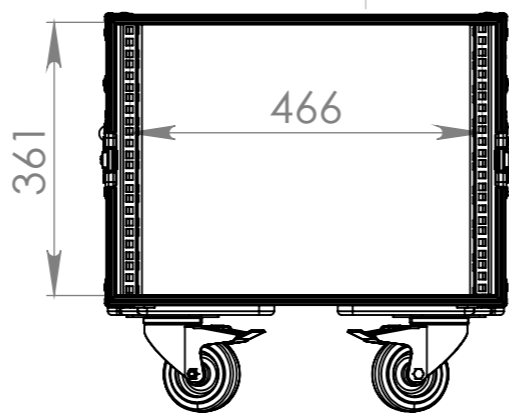
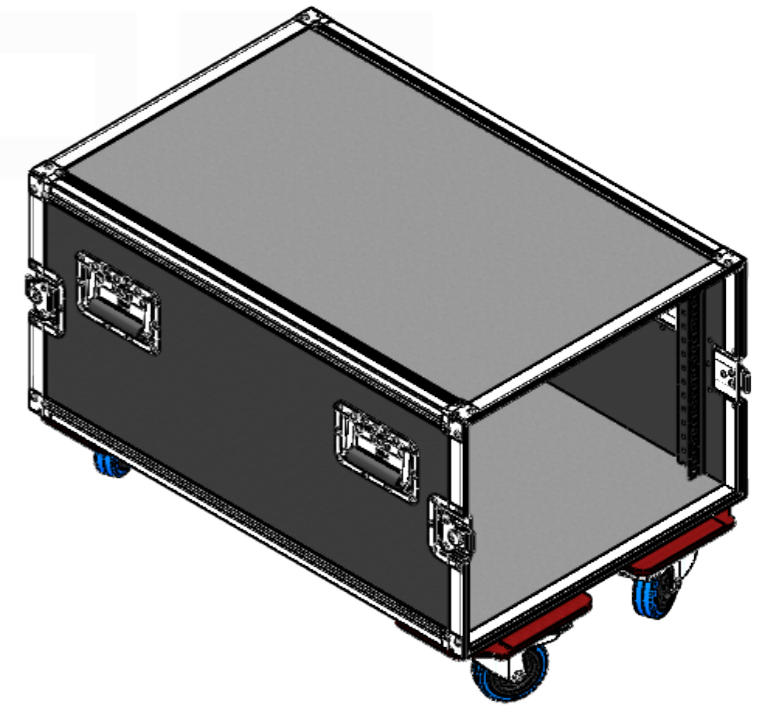

Hardware		
Qty	Ref.	Description
16	40403	Large corner bracket f. 35mm case angle
8	4101	Heavy Duty Ball Corner
4	17290S	Key lockable medium Butterfly special
4	34082	Recessed sprung handle medium model
1	CHAPA.1000	Identification Plate
2	RODA.100T	Swivel castor Ø100mm with brake
2	RODA.100	Swivel castor Ø100 mm

This drawing must not be copied or disclosed without consent of the owner

Drawn by	telmosantos	Date	10/10/2016
Reference	K2T.0877AR		
Scale	1:10	units in mm	general tolerance 0.8mm
DO NOT SCALE			
RACK 19" 2 TAMPAS 8U 775 PROF., RODAS			

