

Interior dimensions		
Width	Depth	Height
19"	250	2Un
Weight	Approx. 6 Kg	
Wall Thickness		7mm

REVISIONS				
ZONE	REV.	DESCRIPTION	DATE	APPROVED
-	-	Final Drawing	15/07/2013	Daniel Lopes

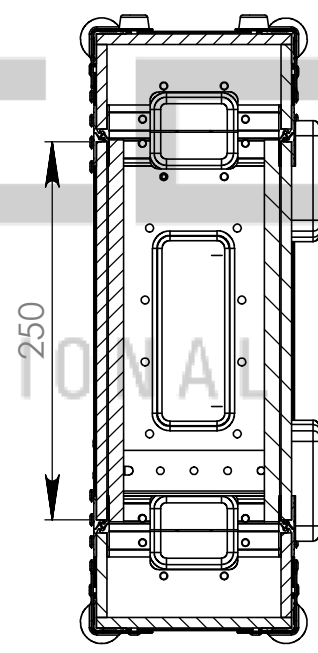

SECTION A-A

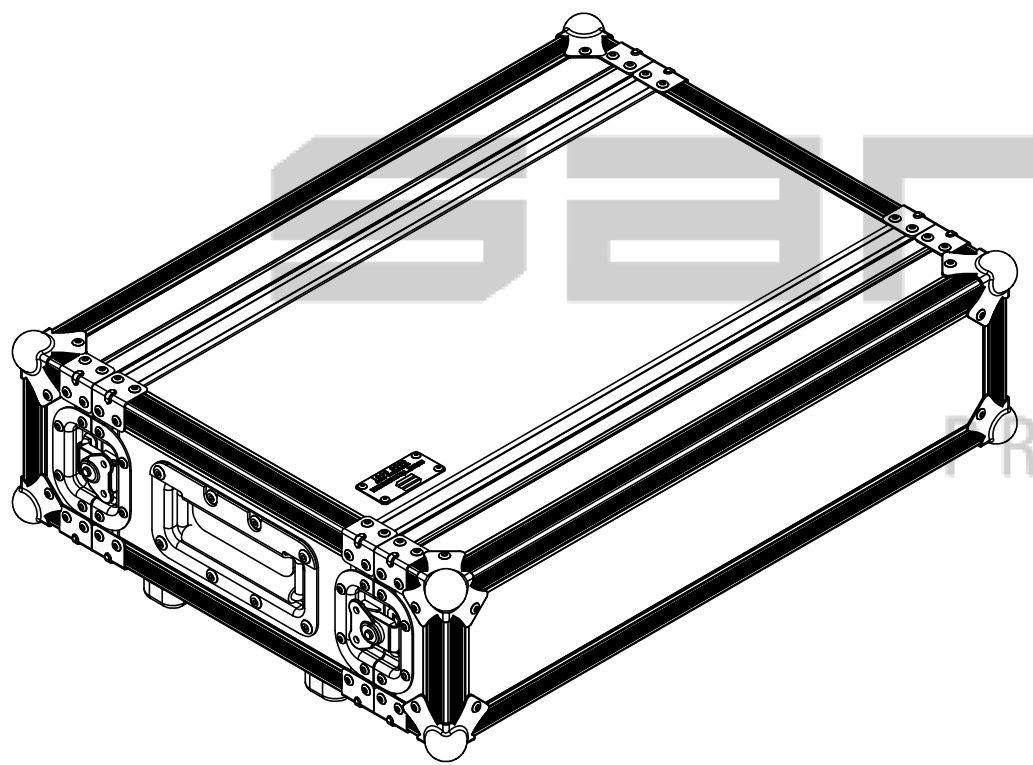
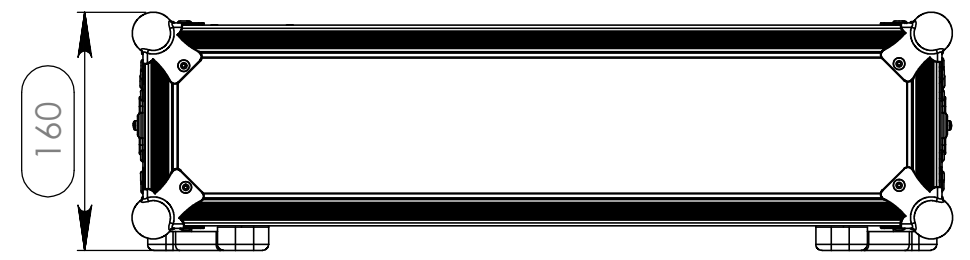
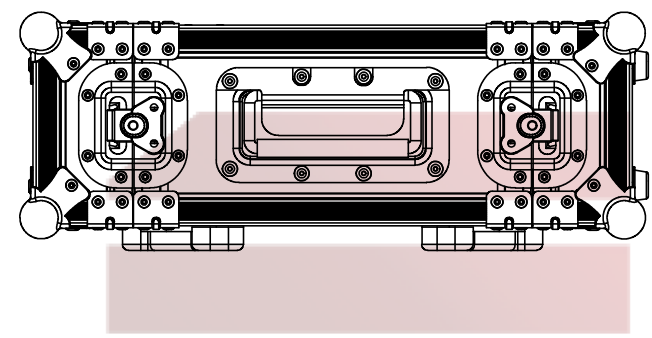
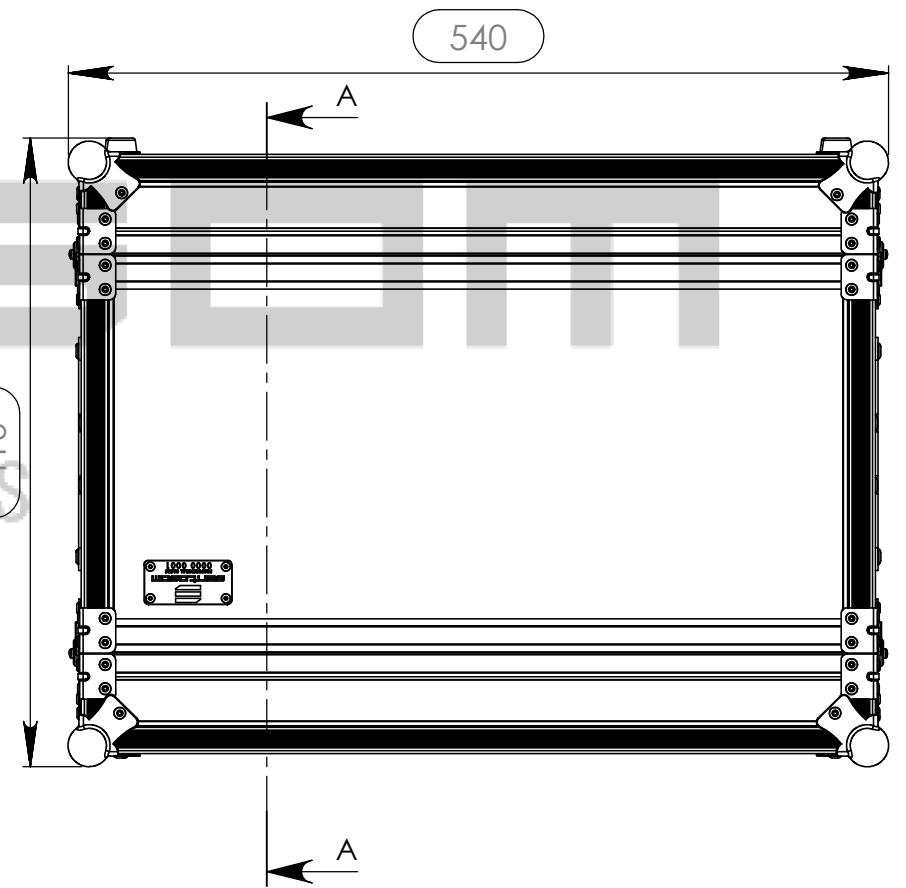

Hardware		
Qty	Ref.	Description
16	40407	Medium corner-brace zinc plated 1,0mm
8	4112	Small ball corner - 3 leg - zinc plated
4	4903	Rubber foot 20 x 9 mm, black
4	17373	Small butterfly catch assembled into ultra compact dish
2	340821	Recessed sprung handle - Small

This drawing must not be copied or disclosed without consent of the owner

Drawn by	Name	Date
DanielLopes	DanielLopes	15-07-2013
Reference	K2T.0225A	
Scale	units in mm	general tolerance
1:5	DO NOT SCALE	0.8mm
1st Angle projection	RACK 19" 2 TAMPAS 2U 250 PROF.	

