

Interior dimensions

Width	Depth	Height
198	265	208
Weight	Approx. 6 Kg	
Wall Thickness	7mm	

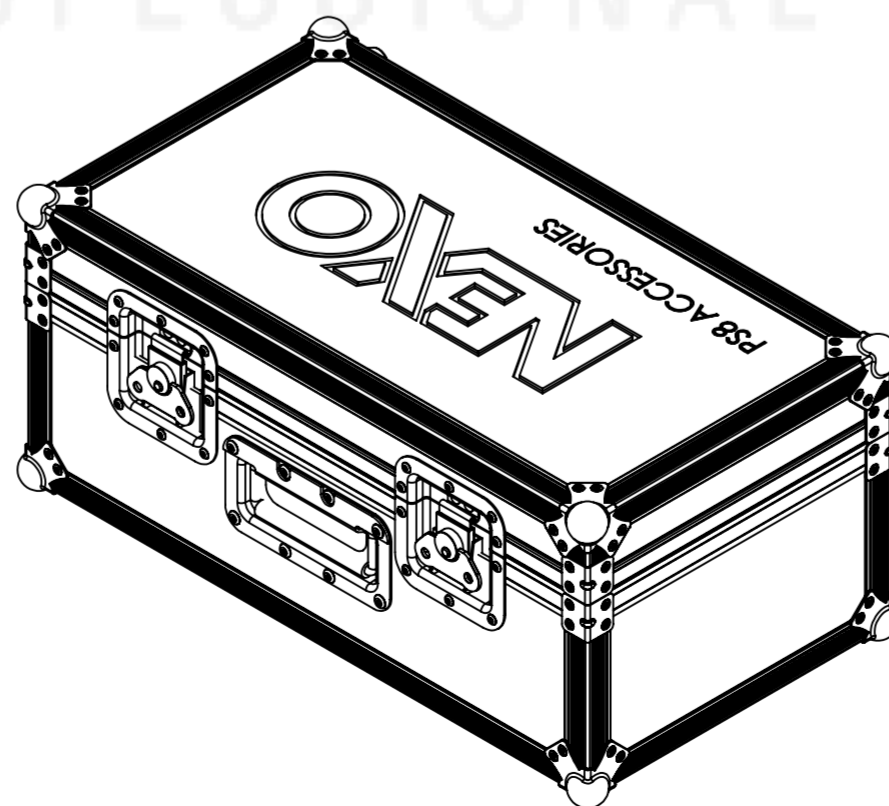
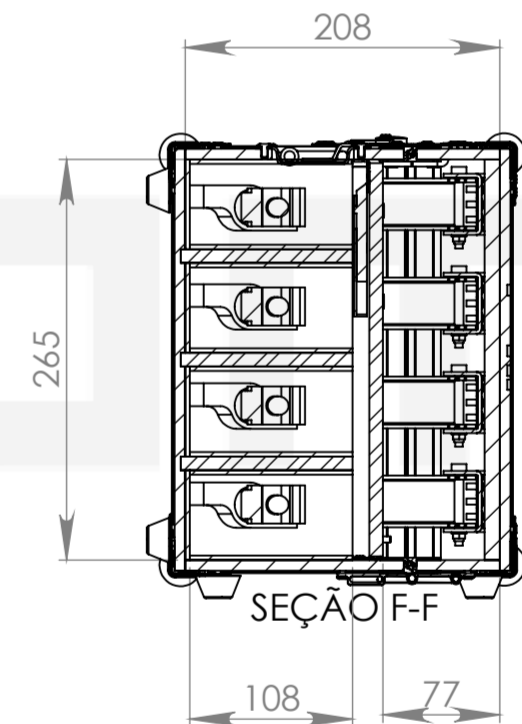
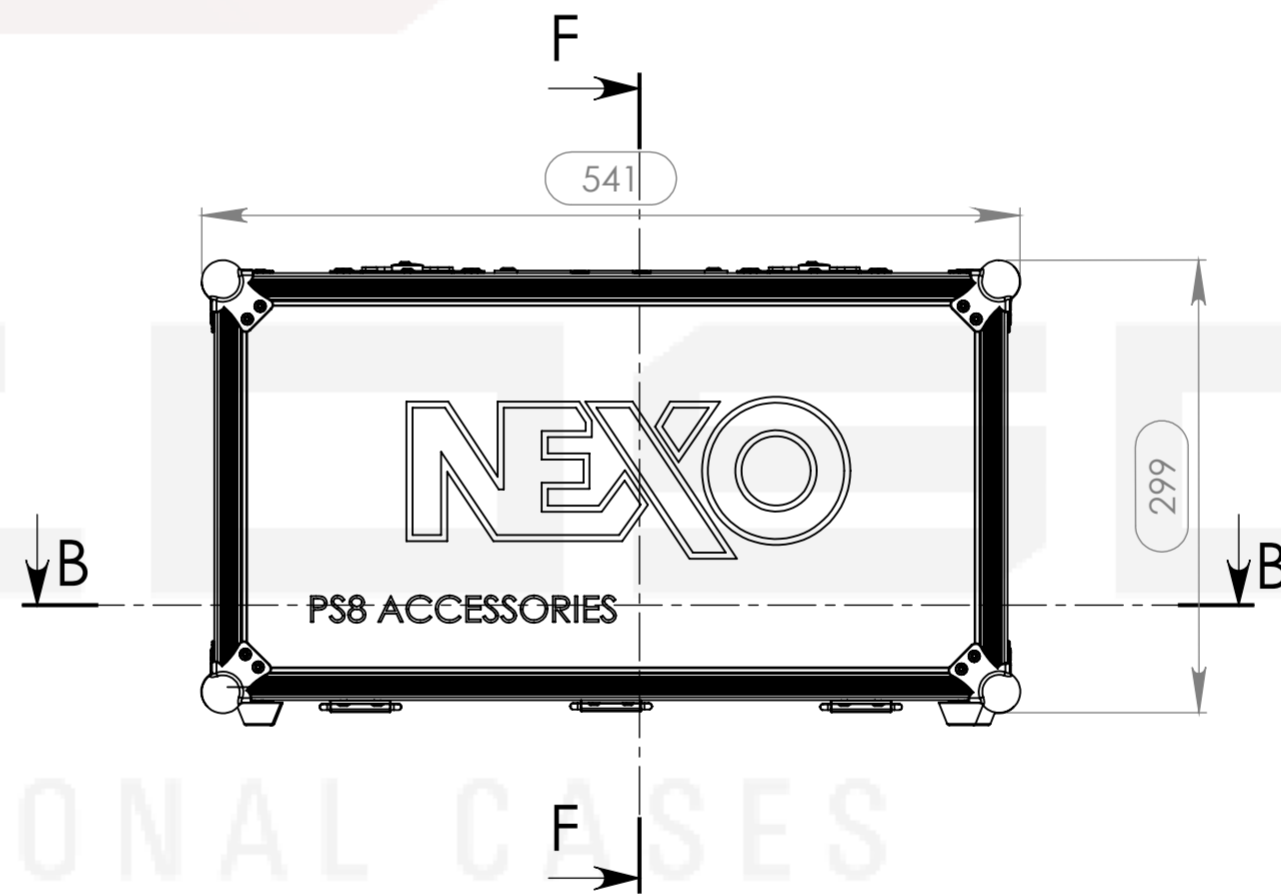
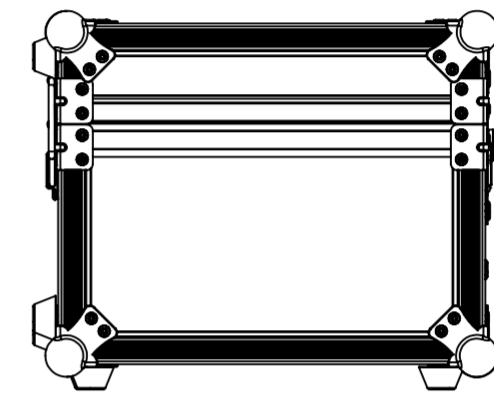
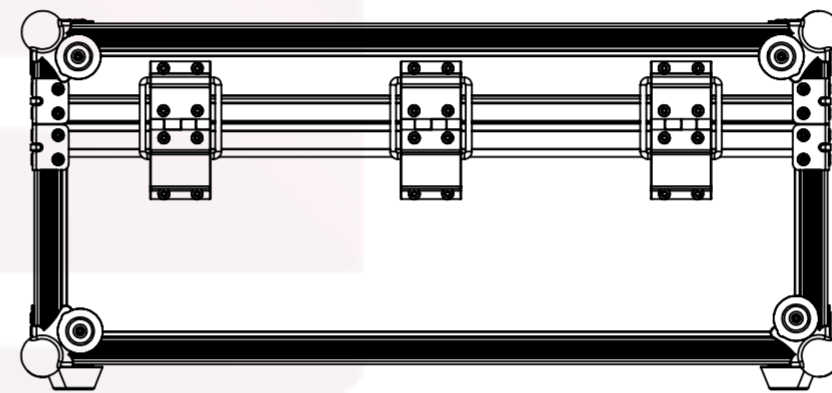
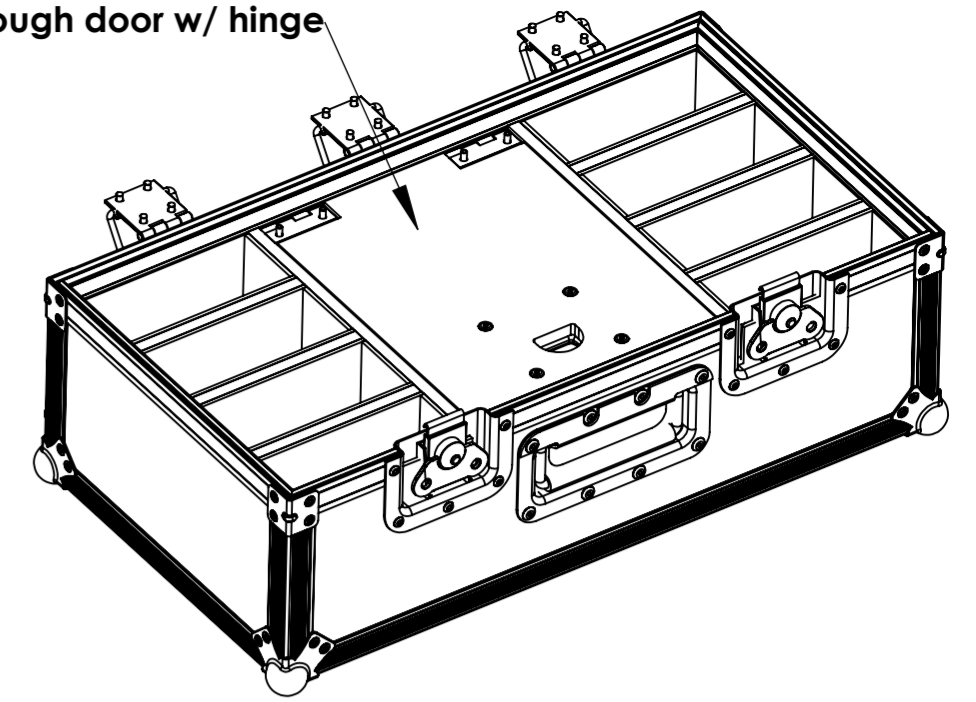
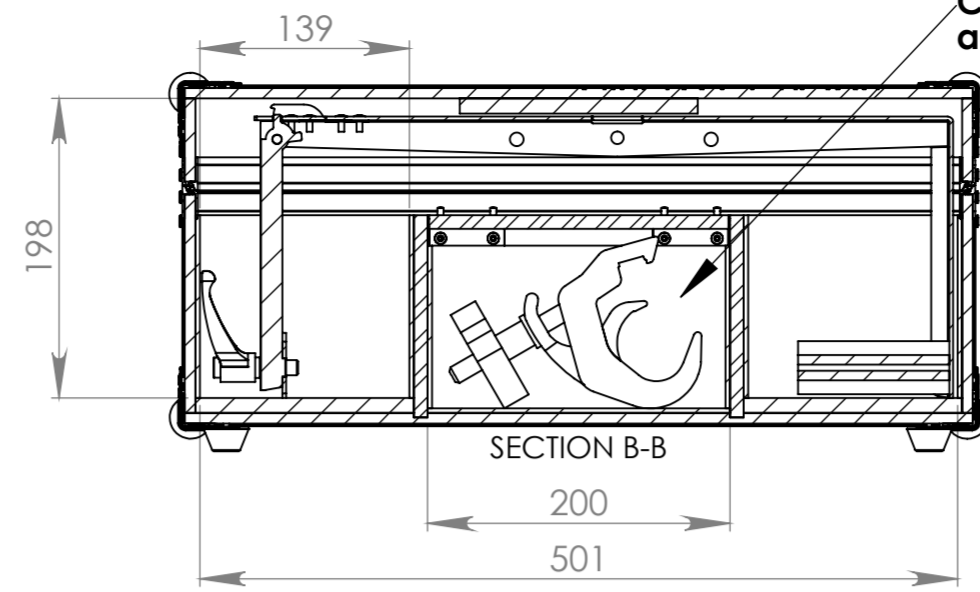
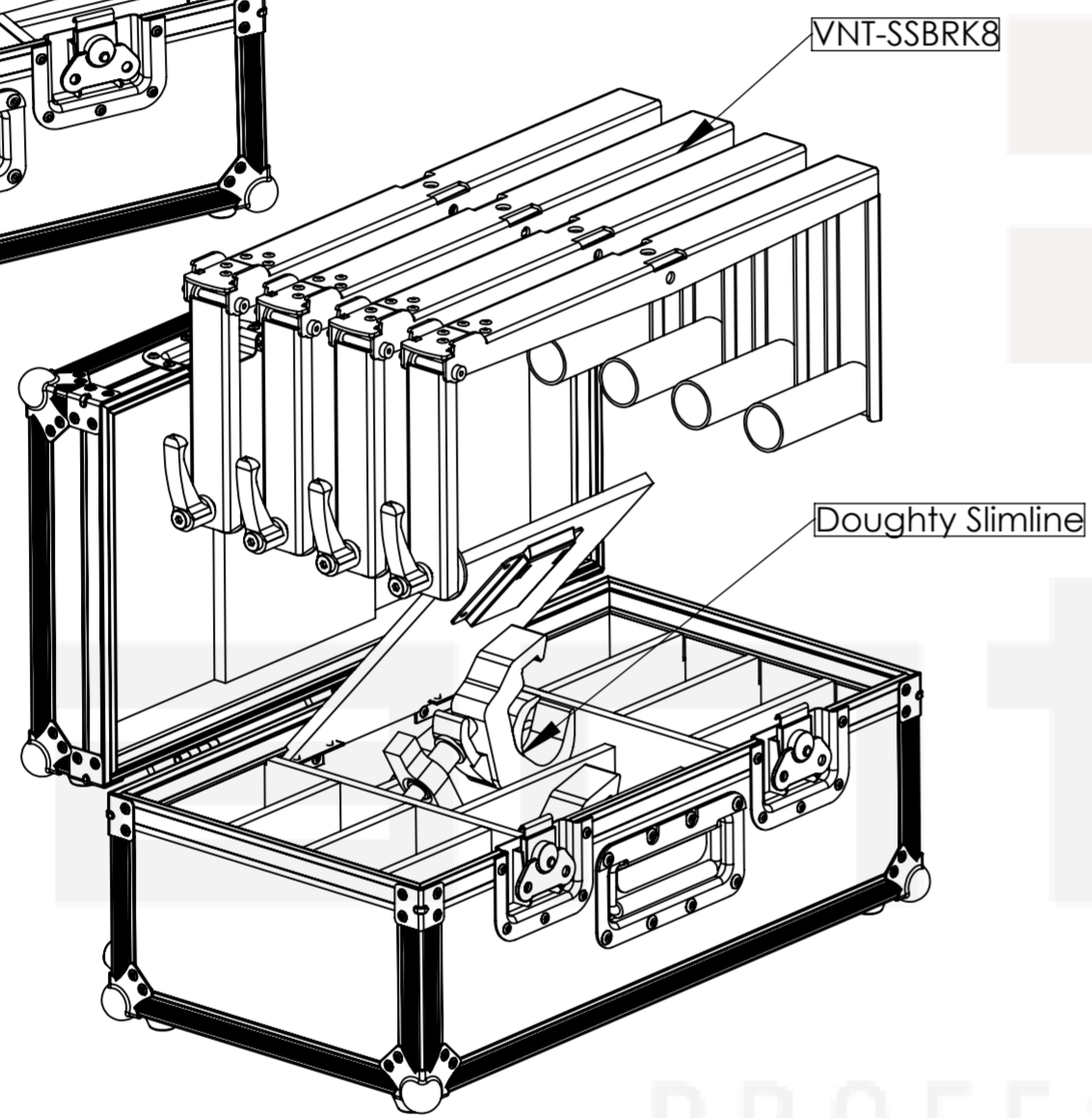
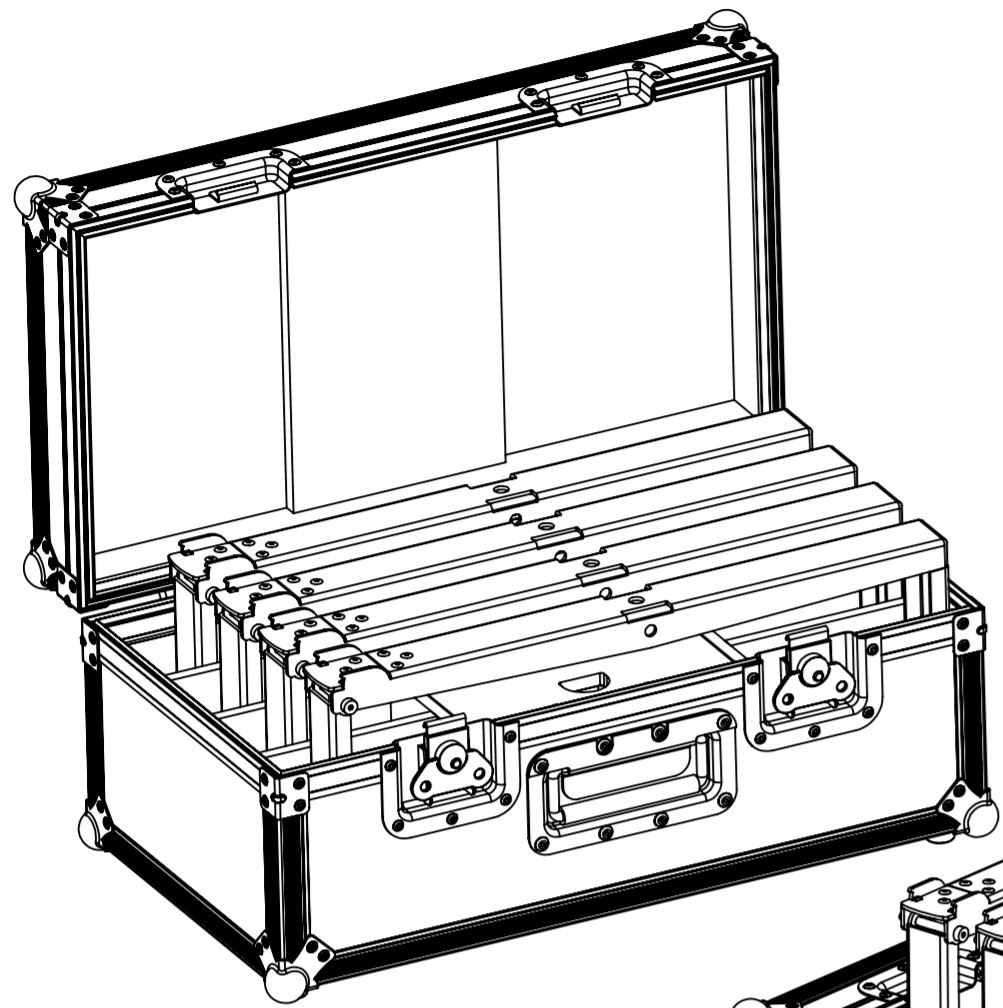

Hardware

Qty	Ref.	Description
8	40407	Medium corner-brace zinc plated 1,0mm
8	4112	Small ball corner - 3 leg - zinc plated
2	17290S	Key lockable medium Butterfly special
3	2524	Heavy Duty Strut Hinge
8	4901	Rubber foot 30 x 15mm, black
1	340822	Recessed sprung handle - Small
2	2601	Hinge small 1,3 mm Steel zinc plated
1	16540	Sliding Latch System - Sliding Latch

This drawing must not be copied or disclosed without consent of the owner

Drawn by	Name	Date
projects	projects	27/06/2017
Reference	FRAME.111	
Scale	1:5	
Units in mm	DO NOT SCALE	general tolerance 0.8mm
1st Angle projection	FC, NEXO PS8 HARDWARE	

