

Internal Dimensions

Width	Depth	Height
163	149	62
Weight	Approx. 0.03 Kg	

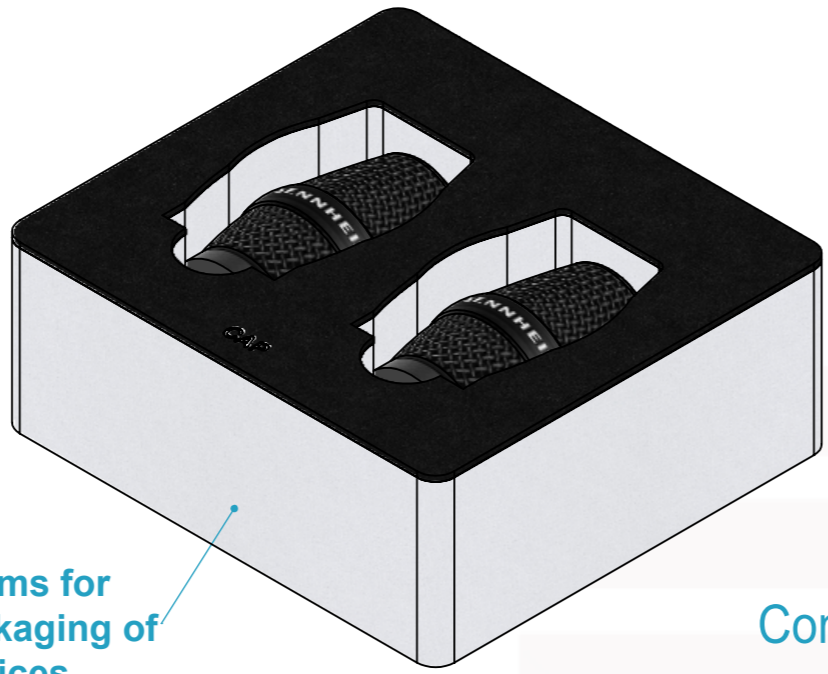

High density foams for protection and packaging of electronic devices

Compatible foams

- * M2.1
- * AD2.M2
- * SE2.M2

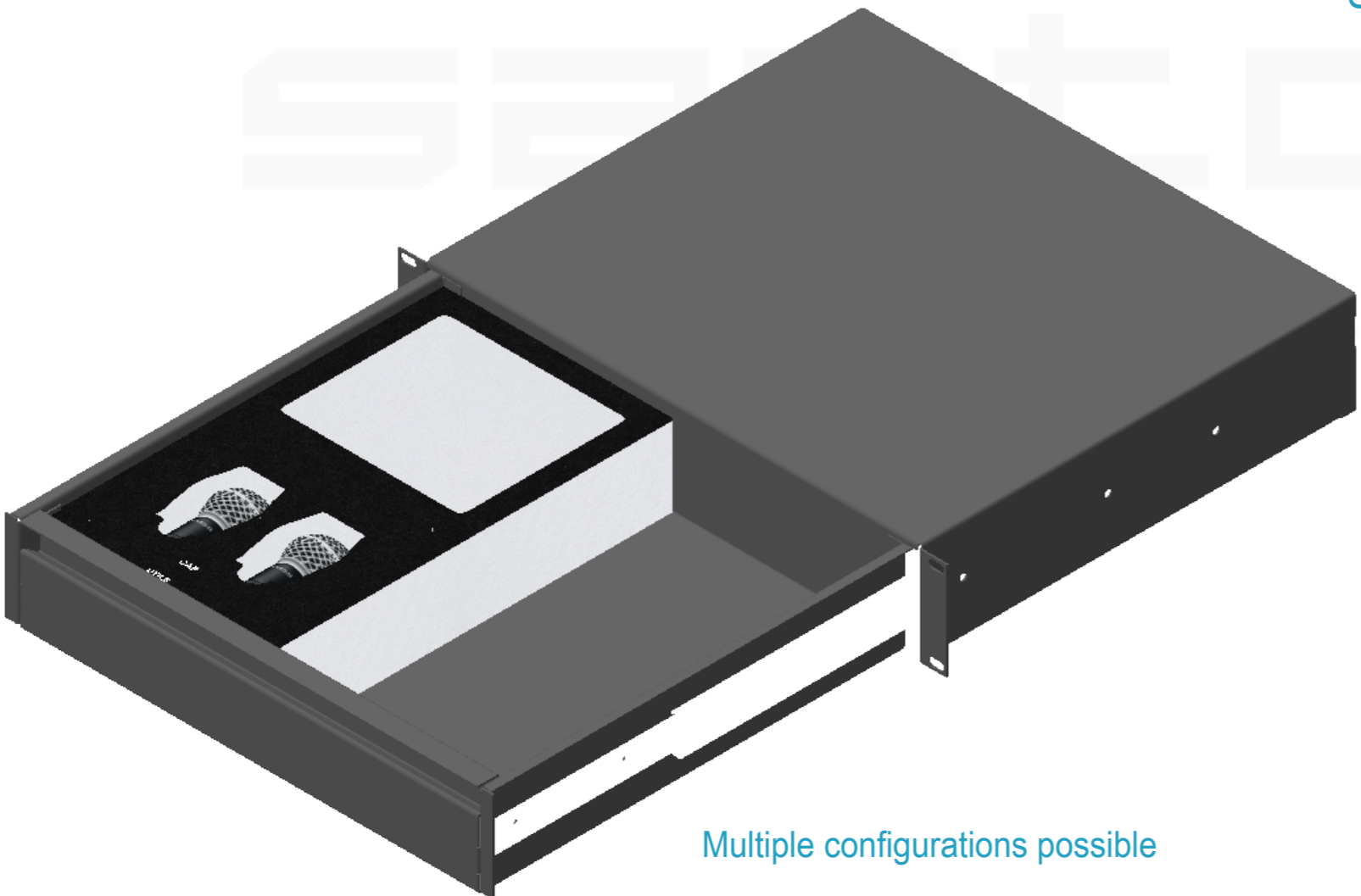
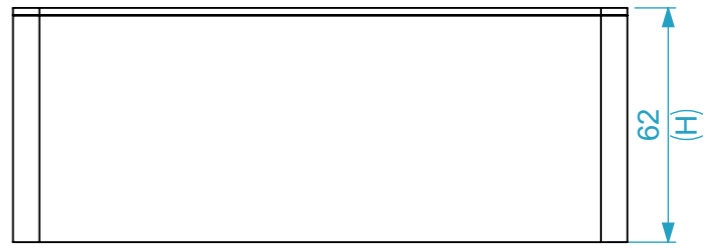

Multiple configurations possible

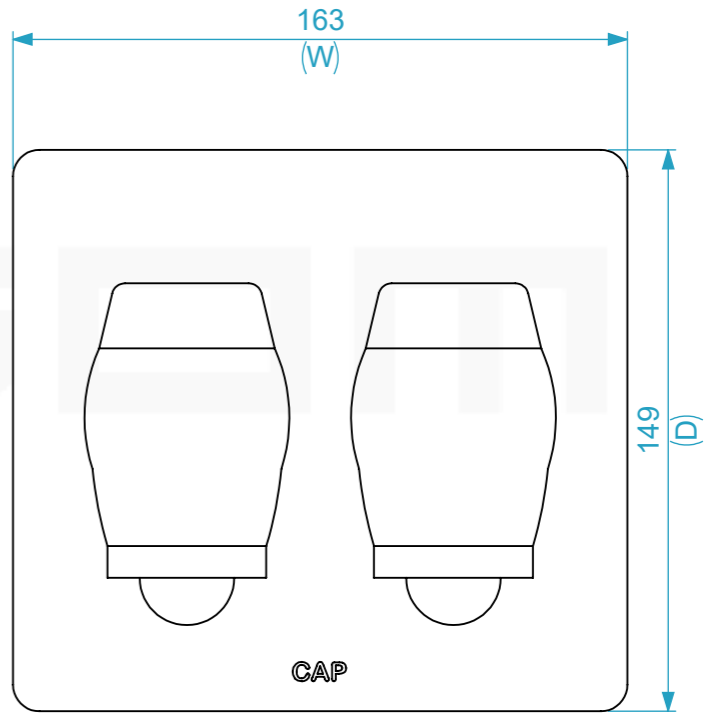

General External Dimensions	
W	Width
D	Depth
H	Height

Name	alvaro.santos	Date	13/10/2022
Reference	FOAM1914.M2.1a		
Scale	1:2	units in mm	DO NOT SCALE
general tolerance	0.8mm		
19" Espuma Inserto Modulo 1/2 Gaveta, 2x CAP			



(*) Devices not included

This drawing must not be copied or disclosed without consent of the owner



A3