

Interior dimensions		
Width	Depth	Height
355	571	782
Weight	Approx. 20.5 Kg	
Wall Thickness		9mm

REVISIONS				
ZONE	REV.	DESCRIPTION	DATE	APPROVED
-	0	Final Drawing	27/02/2014	Pedro Neves

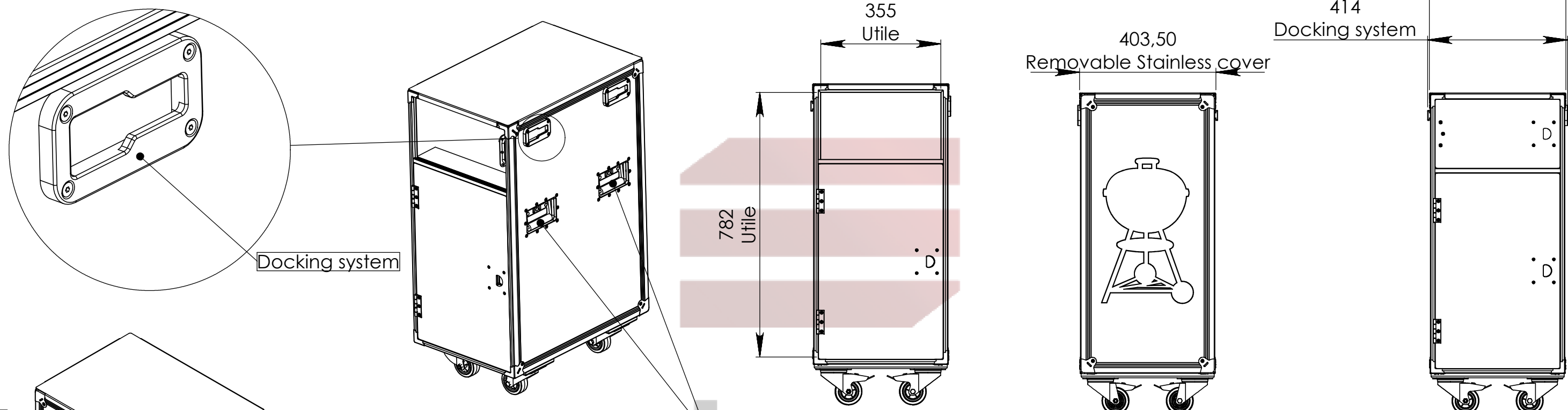

Poignées à l'intérieur de la flight-case pour pouvoir toucher

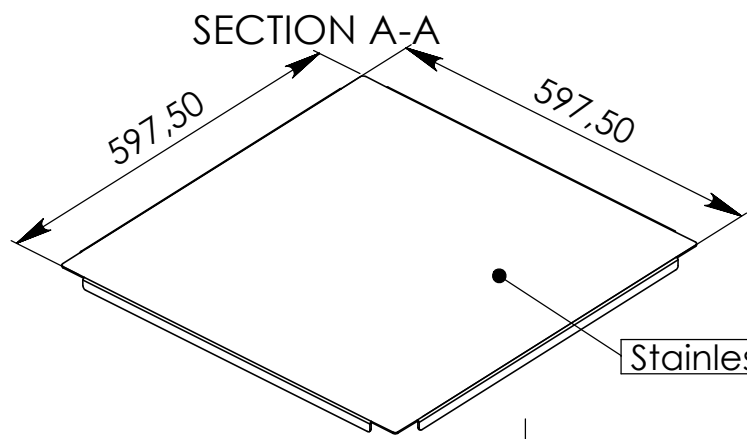
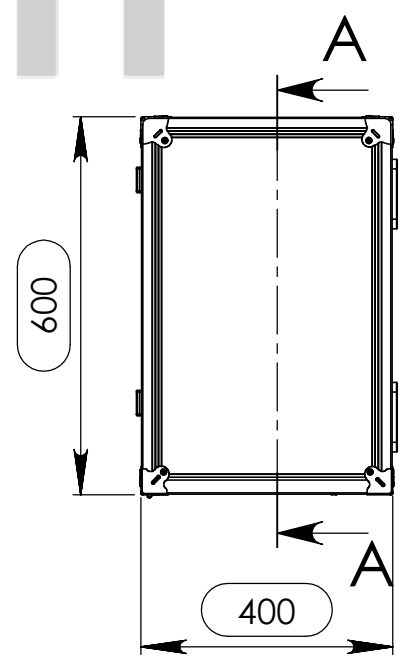
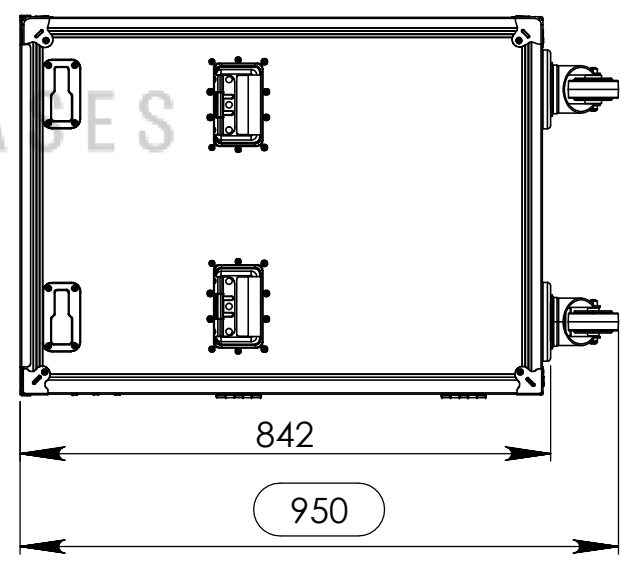
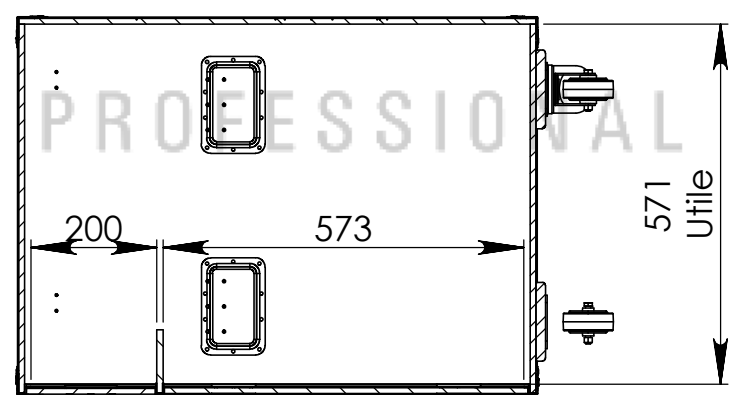

Hardware	
Qty	Description
4	UX-BOX, Corner 2 LEG, 10mm
4	Case corner zinc plated
4	Recessed sprung handle medium model
2	Sliding Latch System - Sliding Latch
2	Swivel castor Ø80 mm with brake
2	Swivel castor Ø80 mm without brake
2	Medium duty butt hinge z./p.

This drawing must not be copied or disclosed without consent of the owner

Drawn by	Name	Date
pedroneves	pedroneves	03-03-2014
Reference	FCI.204	
Scale	units in mm	general tolerance
1:12	DO NOT SCALE	±0,3mm
1st Angle projection	FC, lko rodas	

