

Internal Dimensions		
Width	Depth	Height
376	326	445
Weight	Approx. 9 Kg	
Wall Thickness		7mm

REVISIONS				
ZONE	REV.	DESCRIPTION	DATE	APPROVED
D8	01	Changing equipment dimensions	03/01/2018	Jorge Pacheco

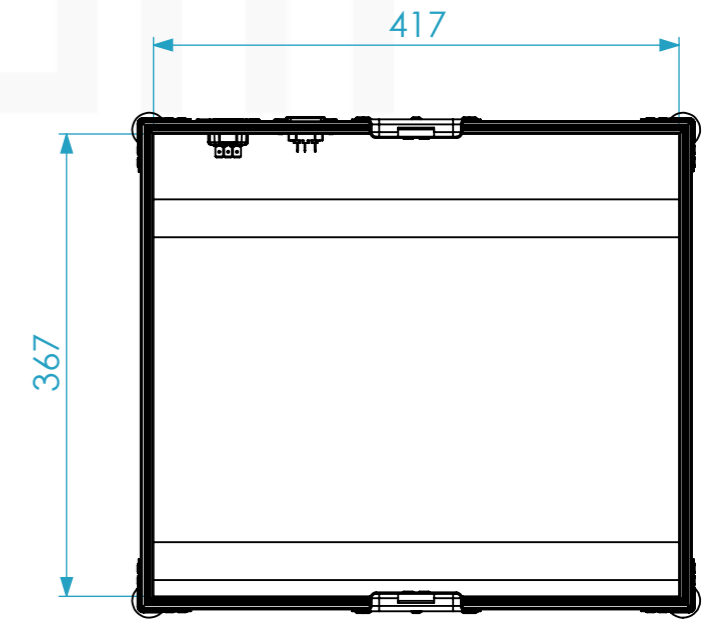
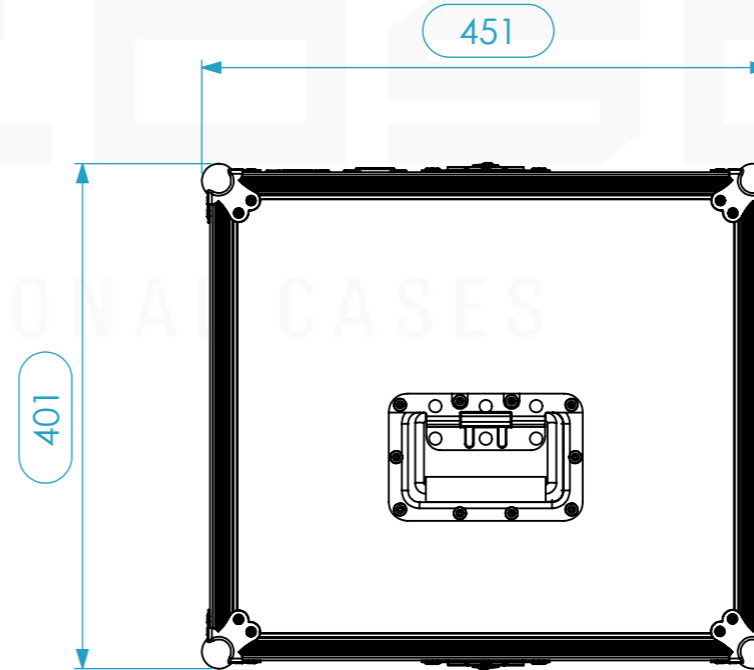
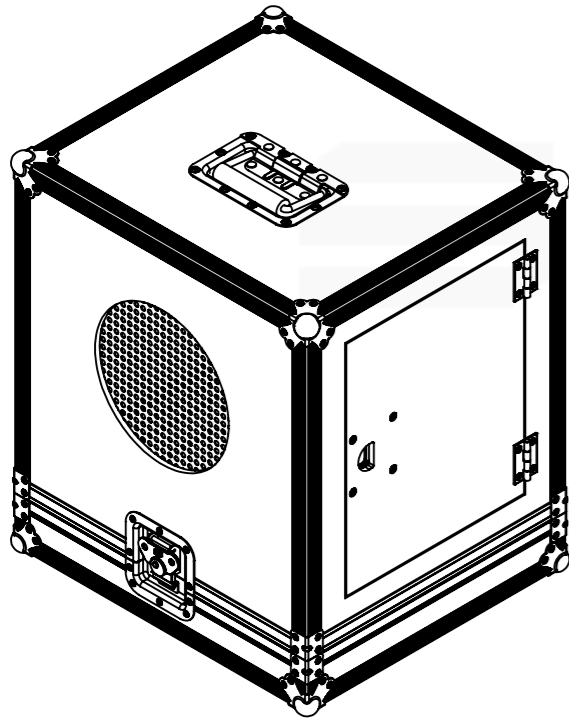
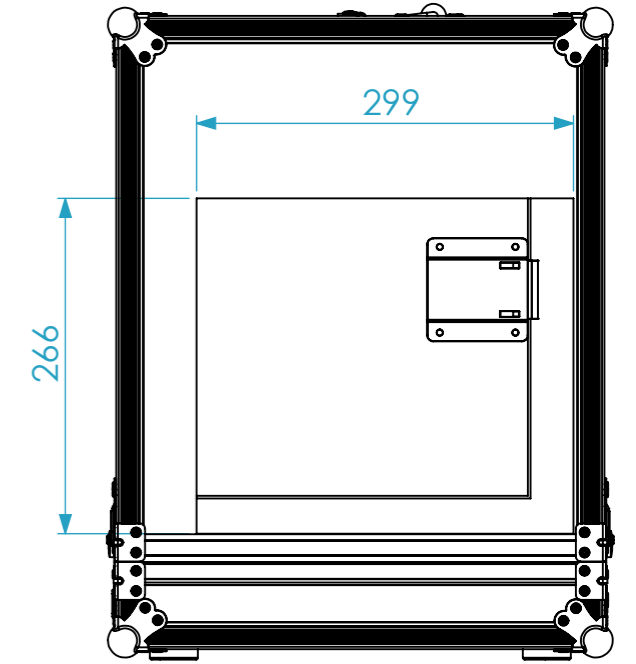
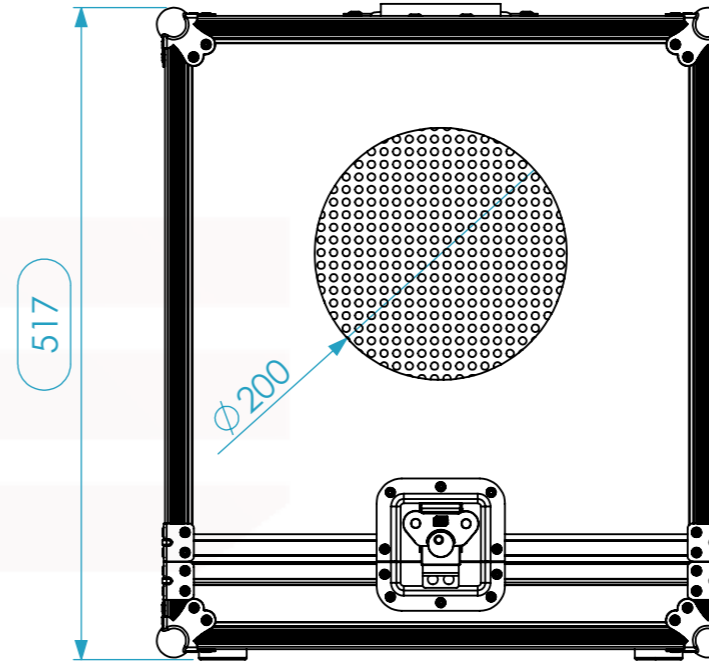
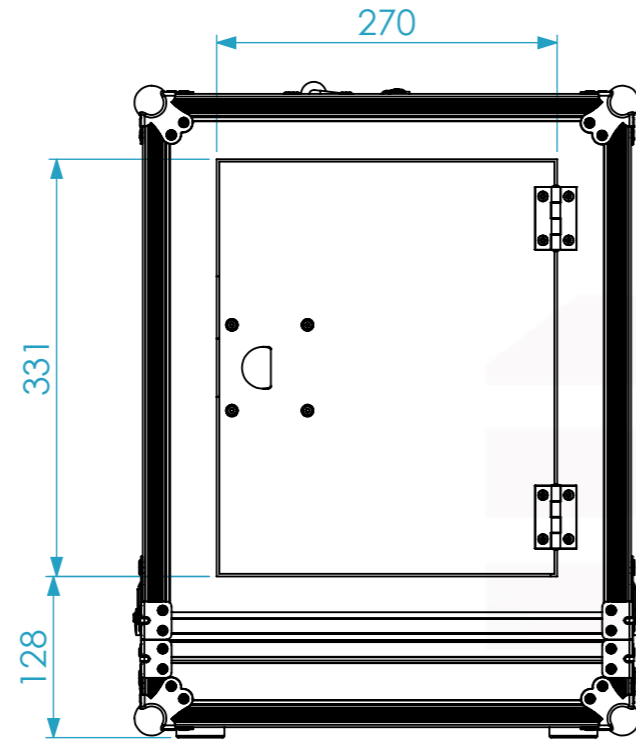
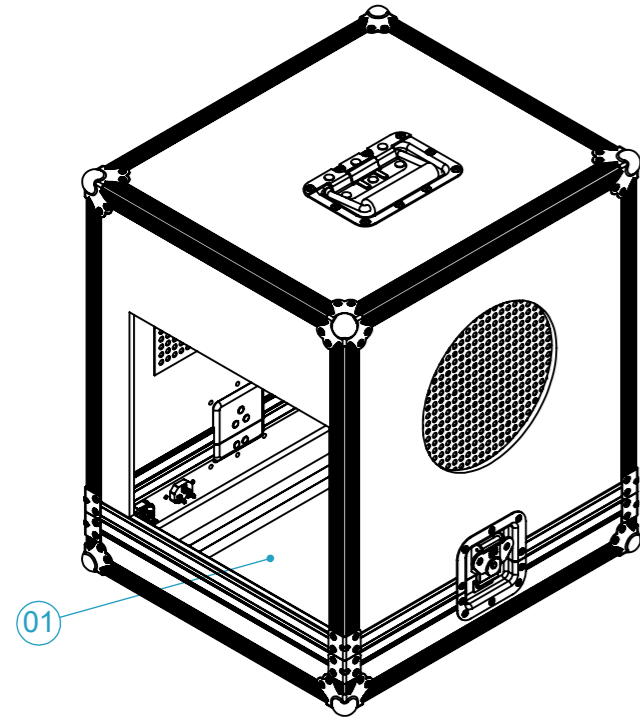

Hardware		
Qty	Ref.	Description
1	34082	Recessed Sprung Handle Medium
8	C1345Z	Small ball corner - 3 leg - zinc plated
8	40407	Medium corner-brace zinc plated 1,0mm
2	17290S	Key lockable medium Butterfly special
4	4906	38 mm rubber foot black H:10 mm.
1	16540	Sliding Latch System - Sliding Latch
2	2601	Hinge small 1,3 mm Steel zinc plated

This drawing must not be copied or disclosed without consent of the owner

1st Angle projection

Scale 1:6

units in mm  
DO NOT SCALE  
general tolerance 0.8mm

Drawn by	Name	Date
jorgepacheco		05/01/2018

Reference FCI.181

FC. VENTILADOR DE CÚPULA SOLER&PALAU CBM9/7

