

Interior dimensions		
Width	Depth	Height
515	325	205
Weight	Approx. 5 Kg	
Wall Thickness	6.3mm	

Revision Table				
Index	Rev.	Description	Date	Draw
-	0	Final Drawing	17/06/2013	Pedro Neves

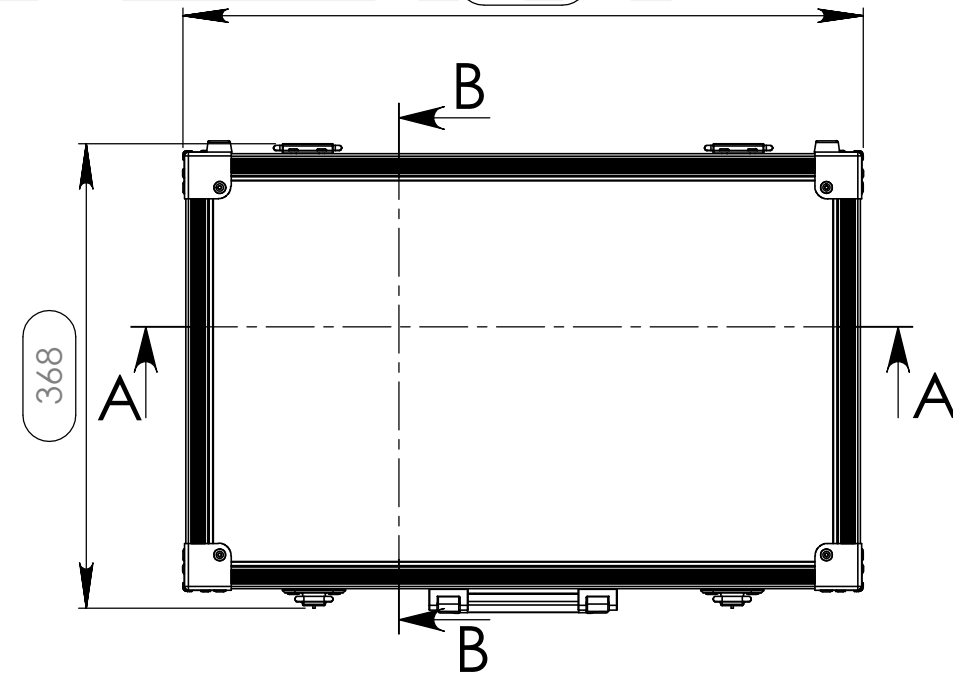
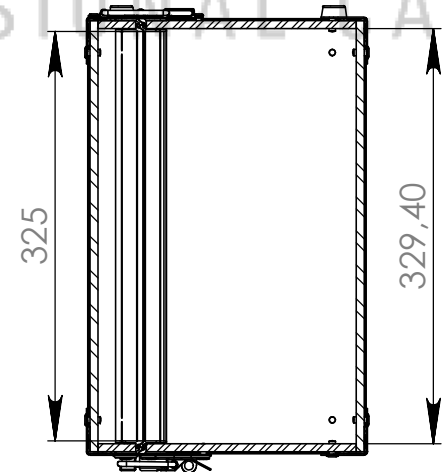
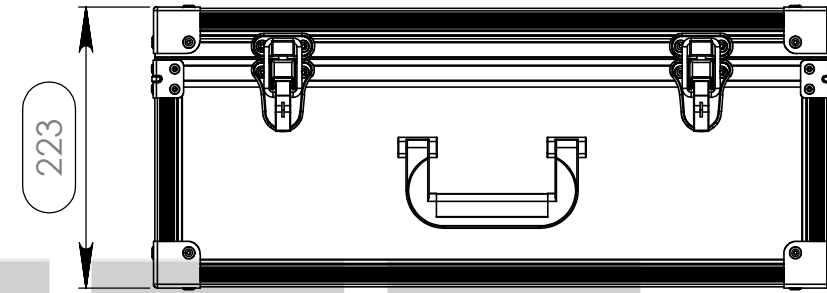
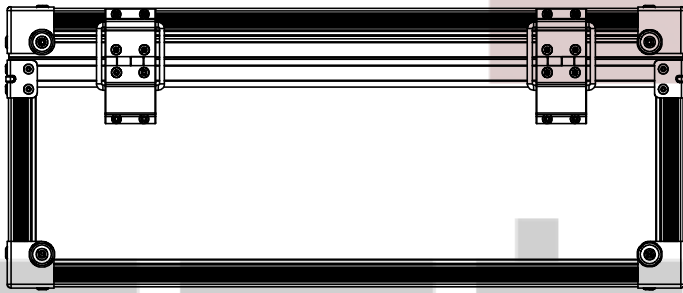
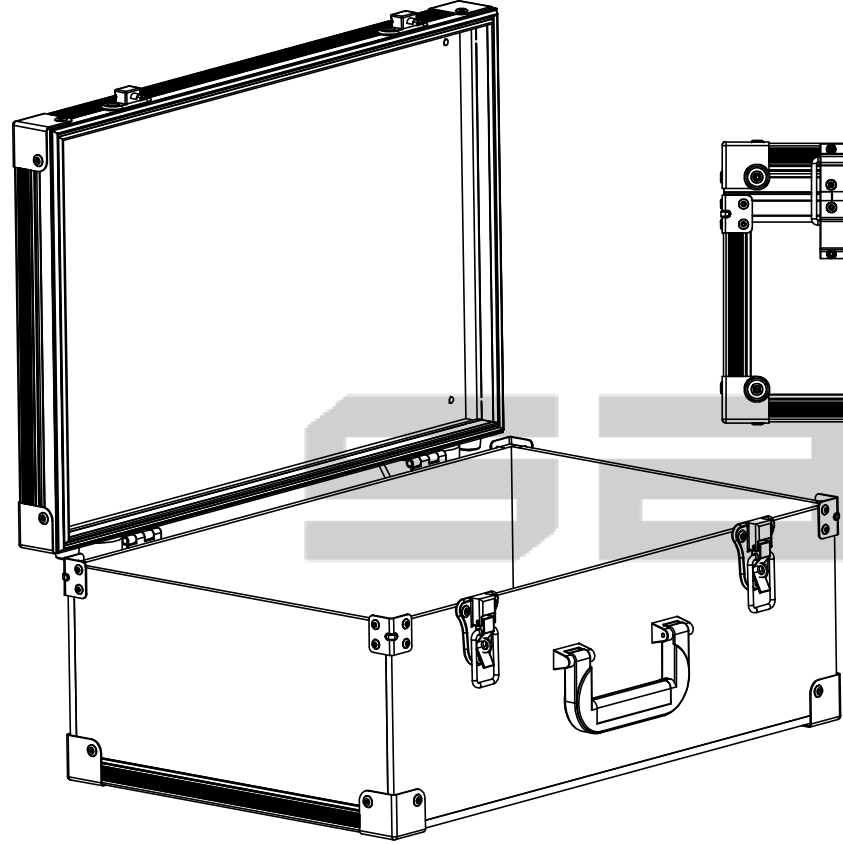
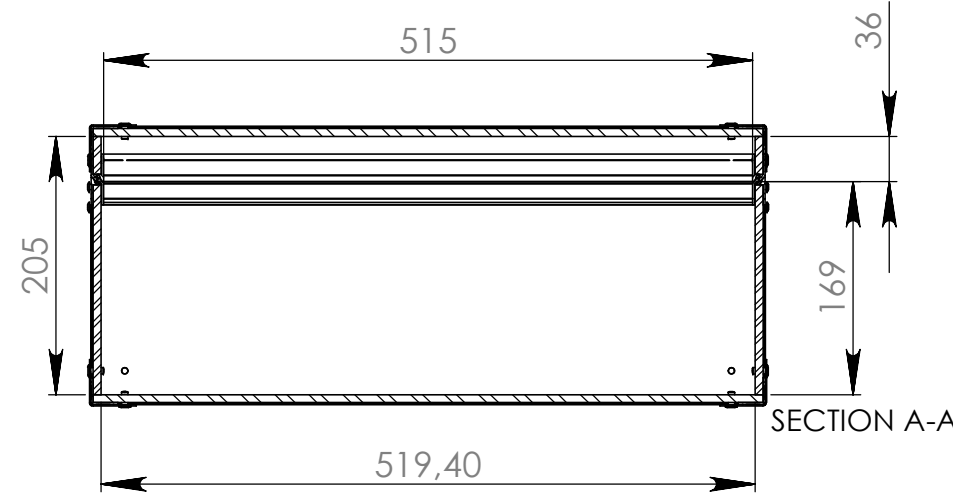
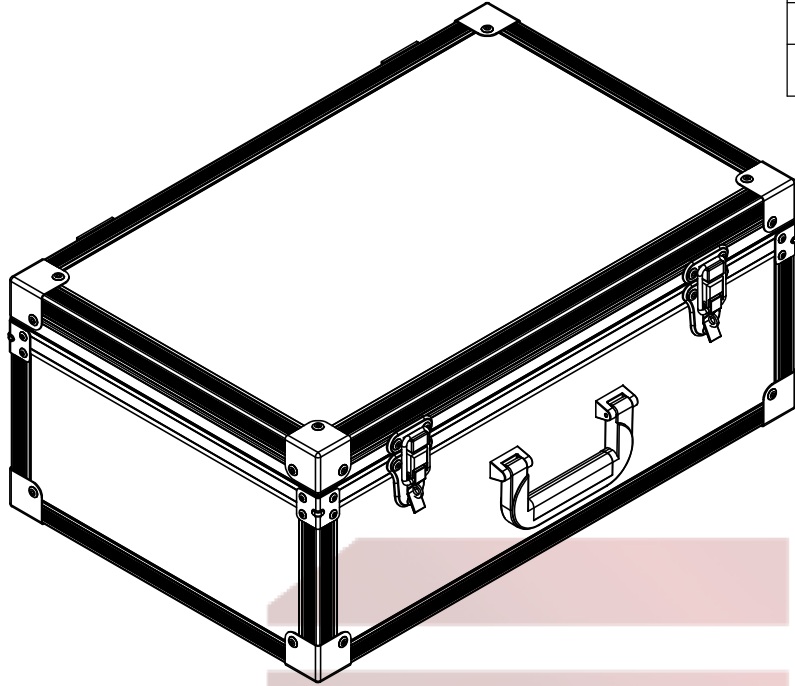

Hardware	
Qty	Description
8	Square Case Corner
4	Medium corner-brace zinc plated 1,0mm
1	Chrome plated plastic with soft black plastic insert
2	Heavy Duty Strut Hinge, zinc plated
4	Rubber foot 20 x 9 mm, black
2	Large padlocking drawbolt

This drawing must not be copied or disclosed without consent of the owner

Scale	1:6
units in mm	general tolerance 0,8mm
DO NOT SCALE	
MULTICASE ECOLINE, 515X325X205MM	

