

Internal Dimensions		
Width	Depth	Height
516	516	146
Weight	Approx. 6 Kg	
Wall Thickness		7mm

TABELA DE REVISÕES				
ZONA	REV.	DESCRIÇÃO	DATA	DESENHO

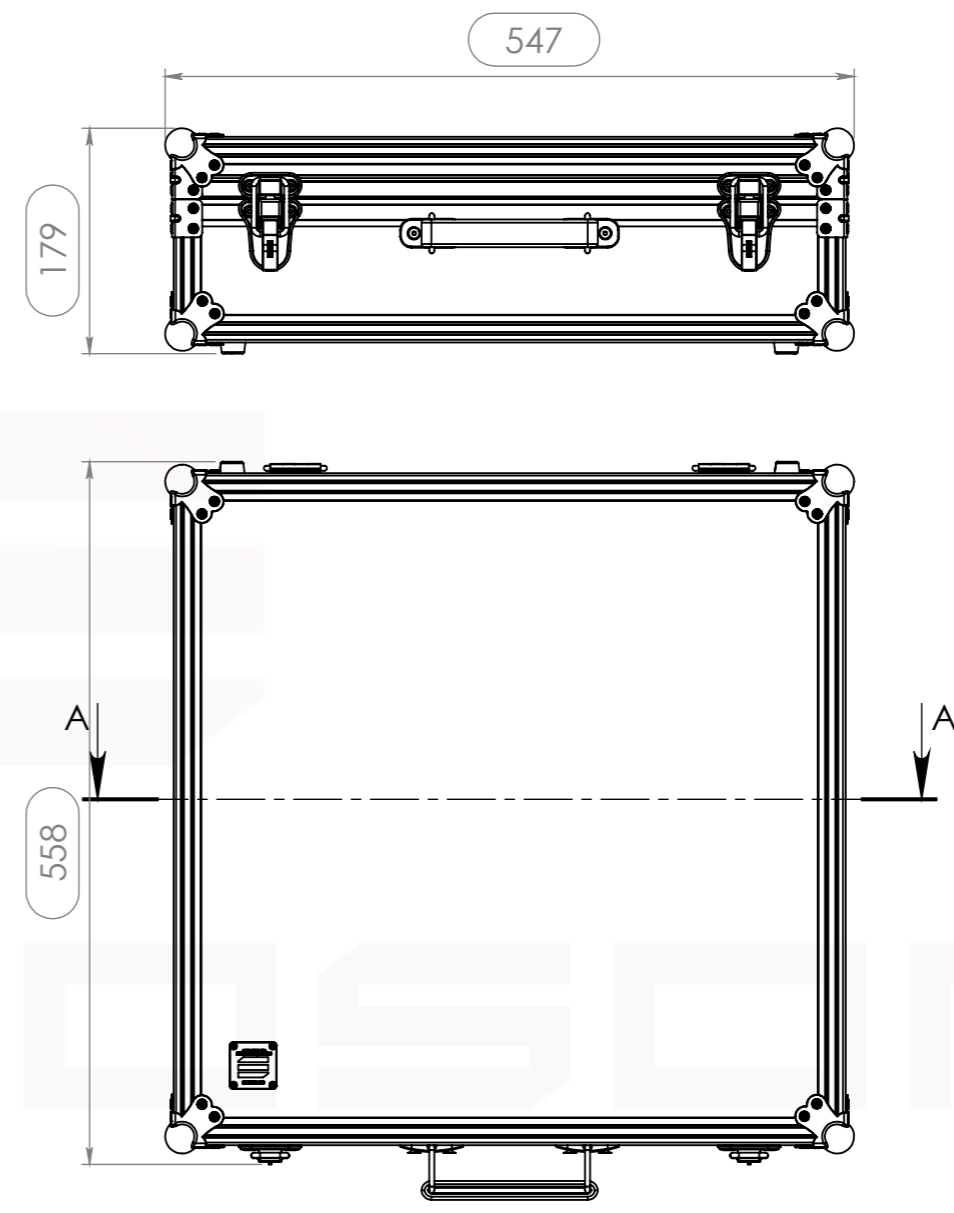

Hardware		
Qty	Ref.	Description
8	40407	Medium corner-brace zinc plated 1,0mm
1	CHAPA.1001	Identification Plate
2	16021	Large padlocking drawbolt
2	2524	HEAVY DUTY STRUT HINGE WITH BLACK PLATE
8	C1345Z	Small ball corner - 3 leg - zinc plated
8	4903	Rubber foot 20 x 9 mm, black
1	3415	Leather Case Handle

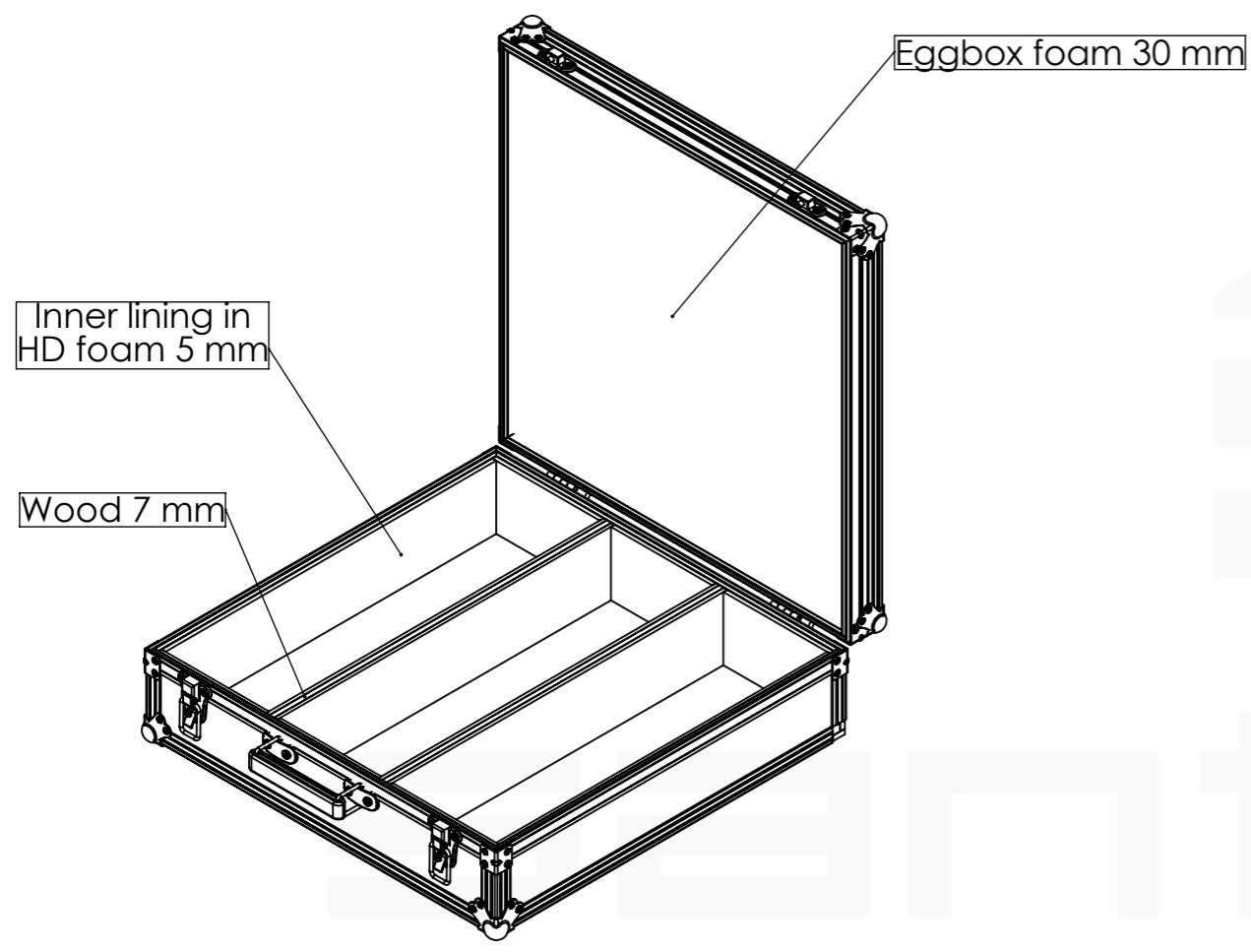
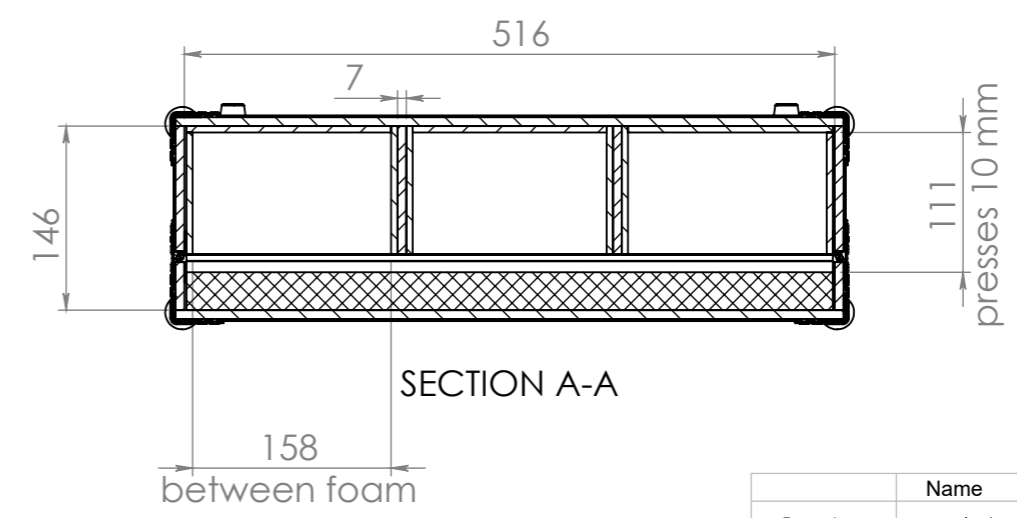

A3 This drawing must not be copied or disclosed without consent of the owner

Drawn by	Name	Date
projects	projects	26/07/2017
Reference	DJCD.150	
Scale	units in mm	general tolerance
1:6	DO NOT SCALE	0.8mm

