

**Equipment** Pioneer DJ CDJ-3000

Width	Depth	Height
329	453	118
<b>Weight</b> Approx. 5.5Kg		
Internal Dimensions		
Width	Depth	Height
426	336	118
<b>Weight</b> Approx. 16.54 Kg		
<b>Wall Thickness</b>		7mm

General External Dimensions	
W	Width
D	Depth
H	Height
Usable Inner Dimensions	
Wi	Inside Width
Di	Inside Depth
Hi	Inside Height

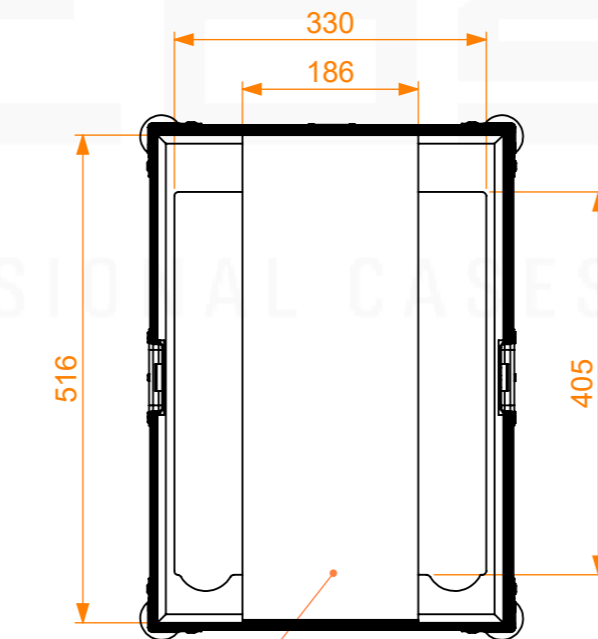
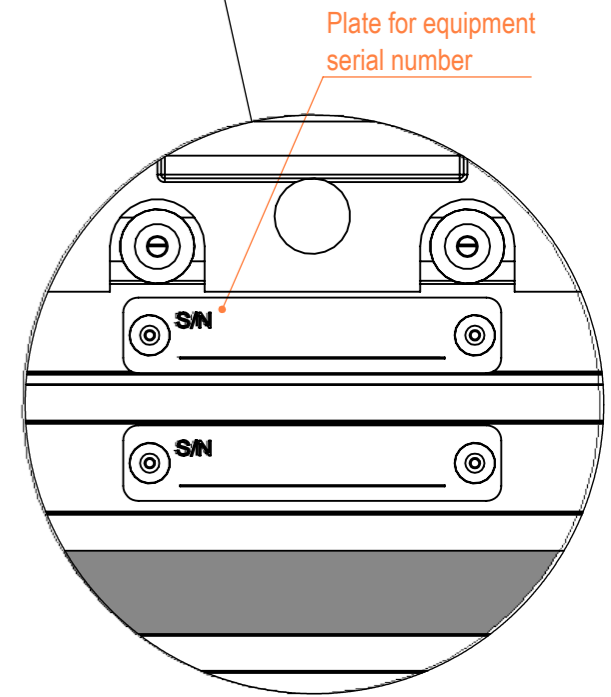
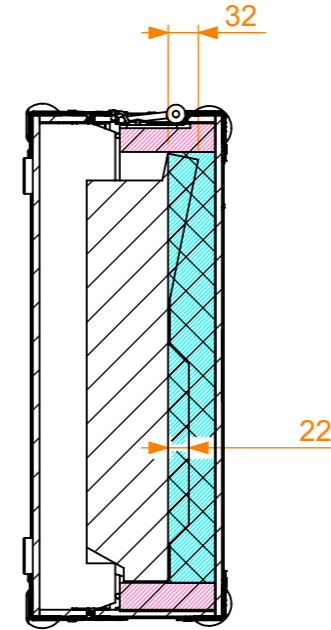
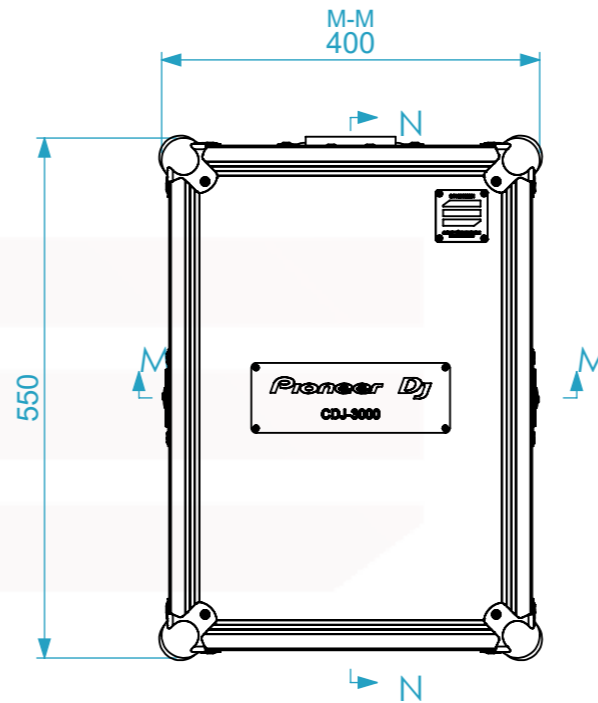
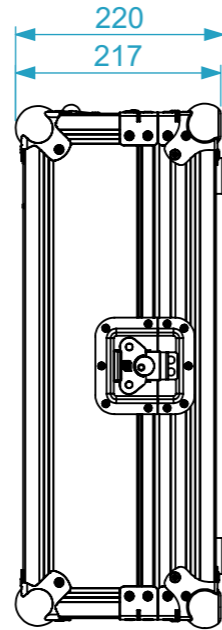
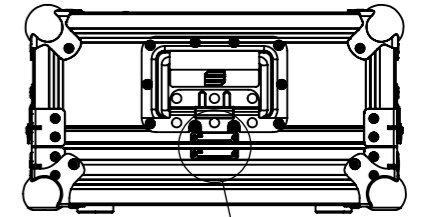
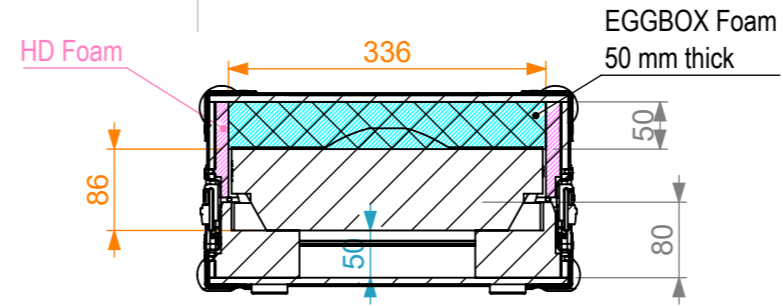
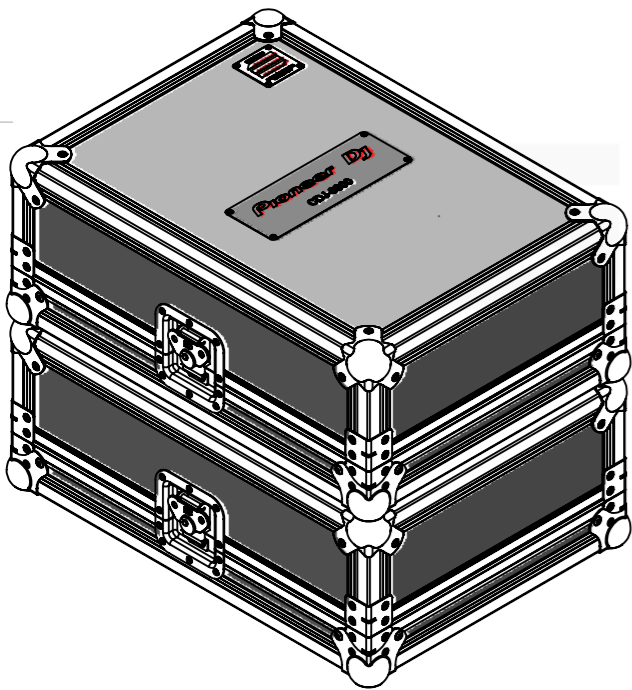
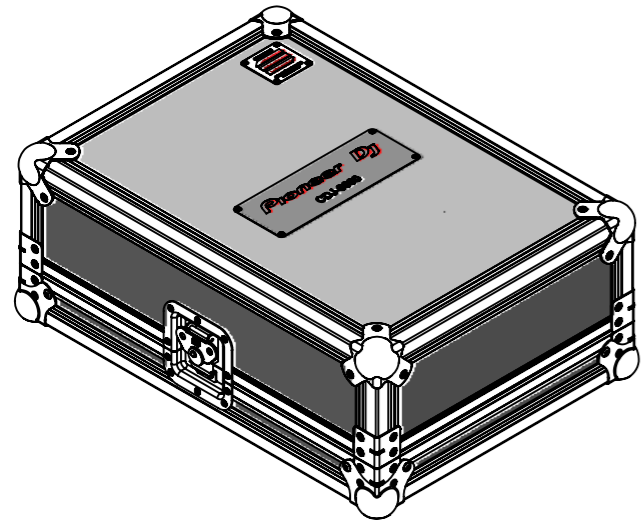

Space for cables

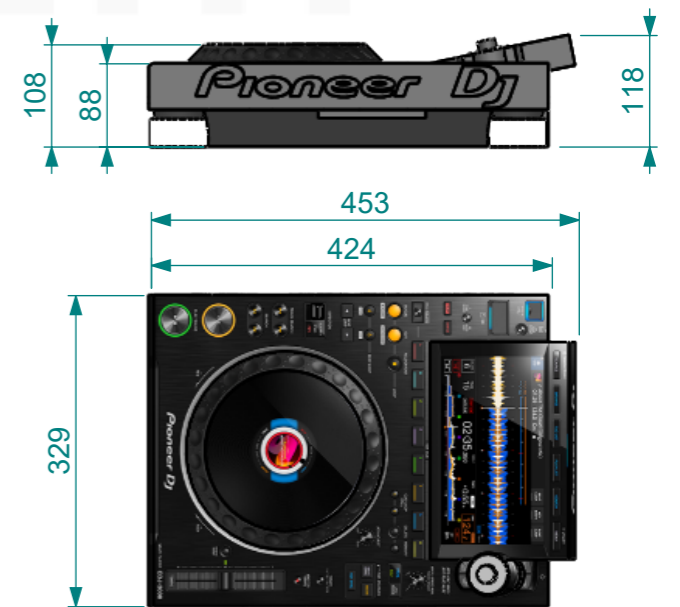

<b>Name</b>	CarlaSilva	<b>Date</b>	12/07/2021
<b>Reference</b>	DJ.U40		
<b>Scale</b>	1:8	<b>units in mm</b>	DO NOT SCALE
<b>general tolerance</b>	0.8mm		
Hand case, Pioneer CDJ-3000			



This drawing must not be copied or disclosed without consent of the owner



A3