

Dimensions		
Width	Depth	Height
483	41	89
Weight	Approx. 0.49 Kg	

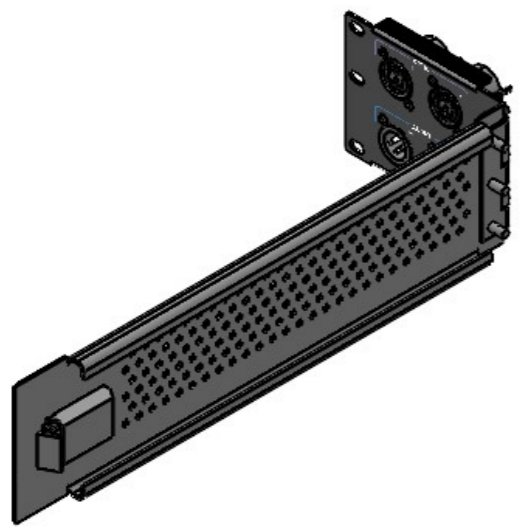
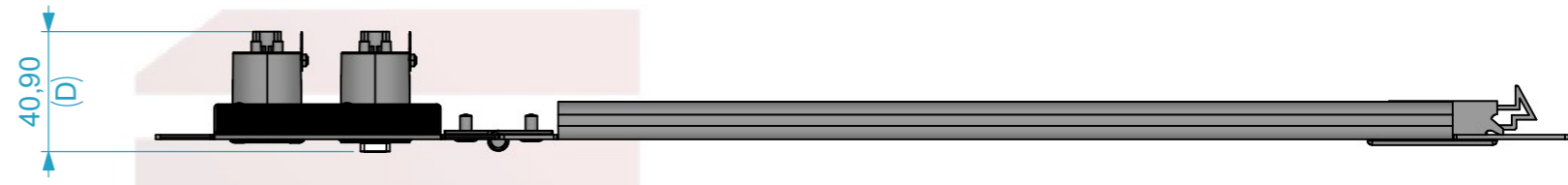
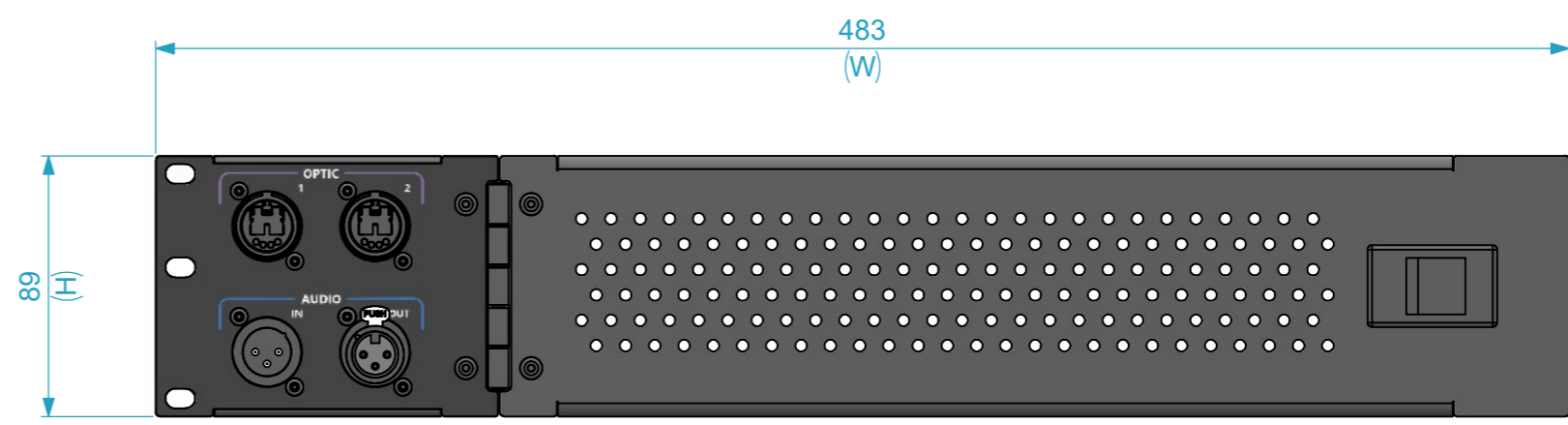

Cables, 1m long

Appliance of opticalCON® Series connector system.

UV imprints features included

Appliance of 3 pole male cable connector with Nickel housing and silver contacts.

Appliance of 3 pole female cable connector with Nickel housing and silver contacts.

19", U shaped Rack panel, 2U.
Epóxi-Polièster RAL 905,
electrostatic paint, fine texture.

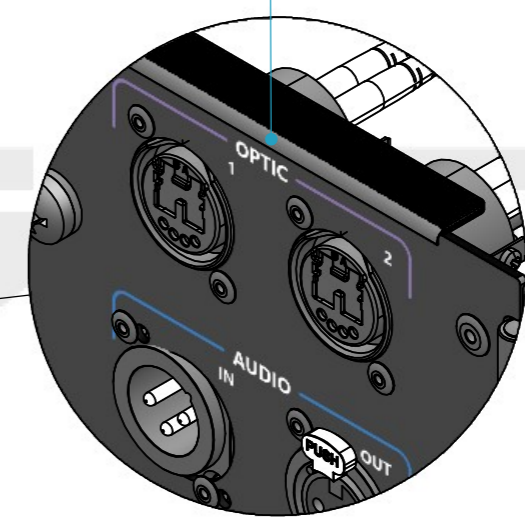

General External Dimensions	
W	Width
D	Depth
H	Height

Name	alvaro.santos	
Date	29/04/2026	
Reference	CSTD.D0202.ADOPT	
Scale	1:2.5	units in mm
DO NOT SCALE		general tolerance 0.8mm
1st Angle projection	Porta com kit de ligações 2U. (Optic 1-2, Audio In-Out)	



This drawing must not be copied or disclosed without consent of the owner

A3