

Dimensions

Width	Depth	Height
483	49.5	44
Weight	Approx. 1.14 Kg	

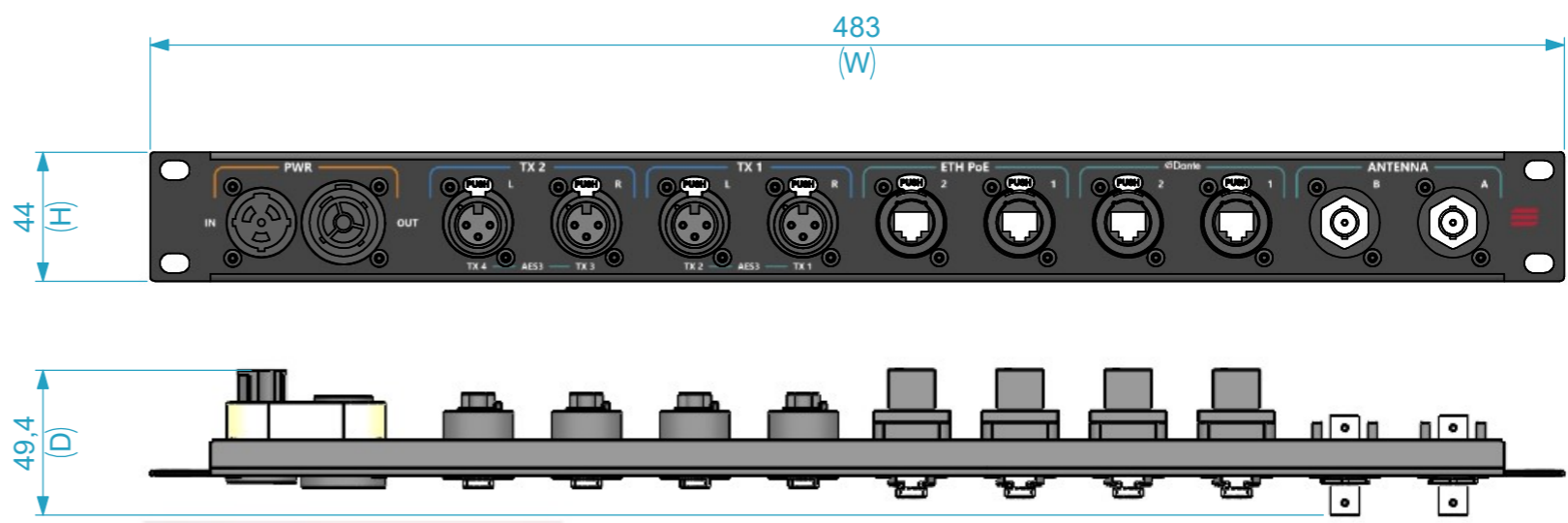

19", U shaped Rack panel, 1U.
Epóxi-Polièster RAL 905, electrostatic
paint, fine texture.

Appliance inlet-outlet combination,
1/4" flat tab terminals, powerCON
TRUE1 TOP with breaking capacity (CBC).

3 pole female receptacle, solder
cups, Nickel housing and silver
contacts.

EtherCON Series RJ45 connector system,
optimized for pro audio, video and lightning
network applications.

Grounded BNC bulkhead for panel mount,
feedthrough, grounded.
(not included, supplied by the installed device).

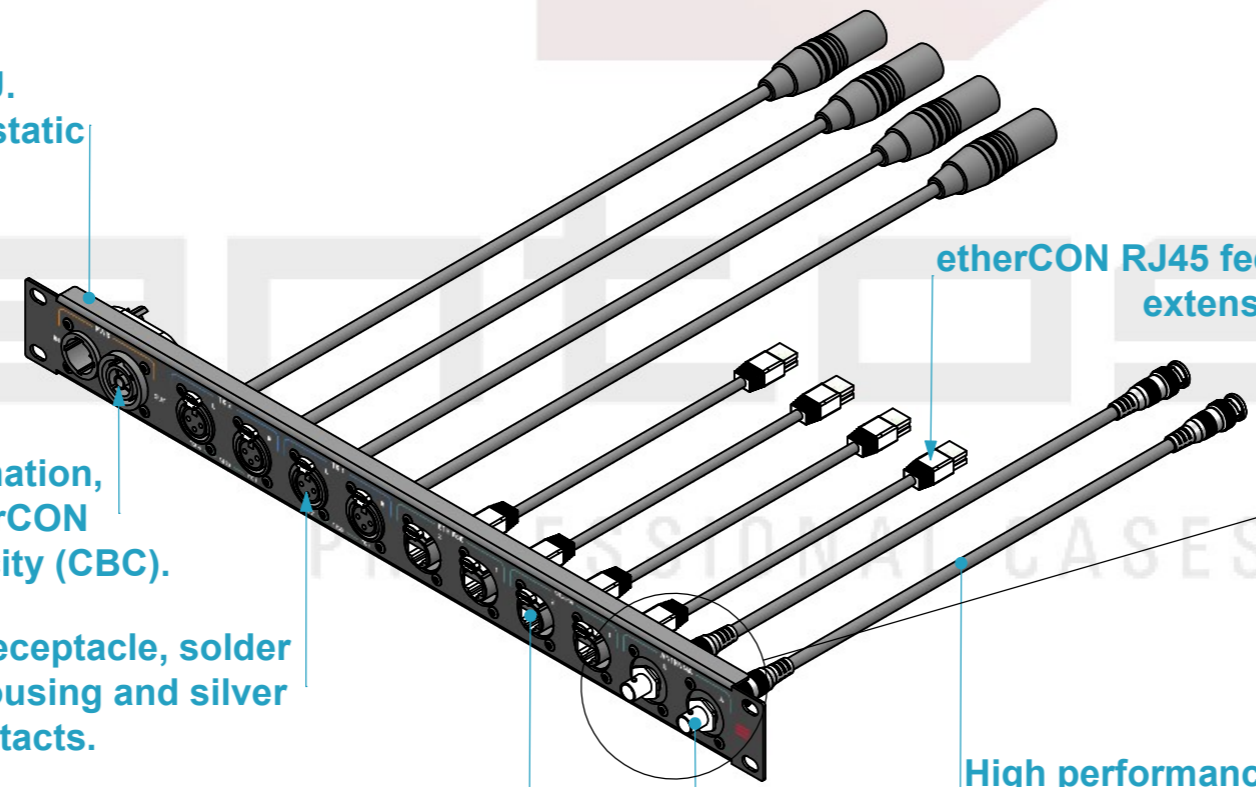

etherCON RJ45 feedthrough cable
extensions.

High performance 50Ohm feedthrough cable
extensions.

UV imprints included

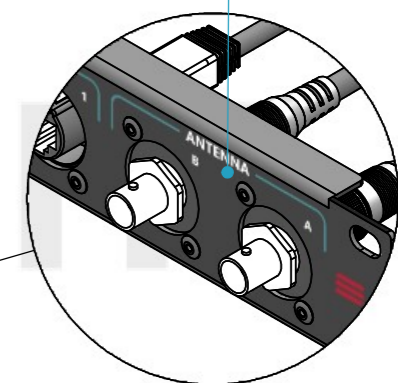

General External Dimensions	
W	Width
D	Depth
H	Height

Name	alvaro.santos	
Date	13/05/2026	
Reference	CST.AW10.IEM2	
Scale	1:2.5	units in mm
DO NOT SCALE	general tolerance	0.8mm



This drawing must not be
copied or disclosed without
consent of the owner



19, completo com impressões, fichas e ligações incluídas.