

Equipment	Barco EC-30	
Width	Depth	Height
465.6	321	105.4
Weight (Equipment)	Approx. 3.18Kg	
Weight (Flight case)	Approx. 20 Kg	

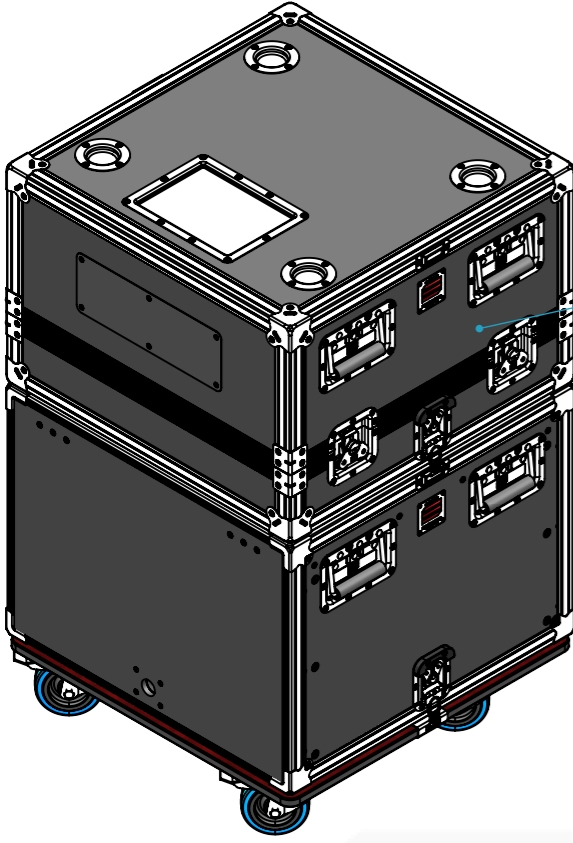

Stackable with RCS Racks

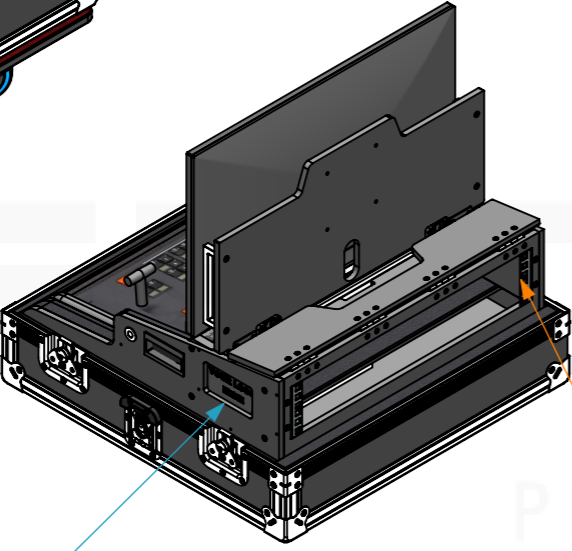
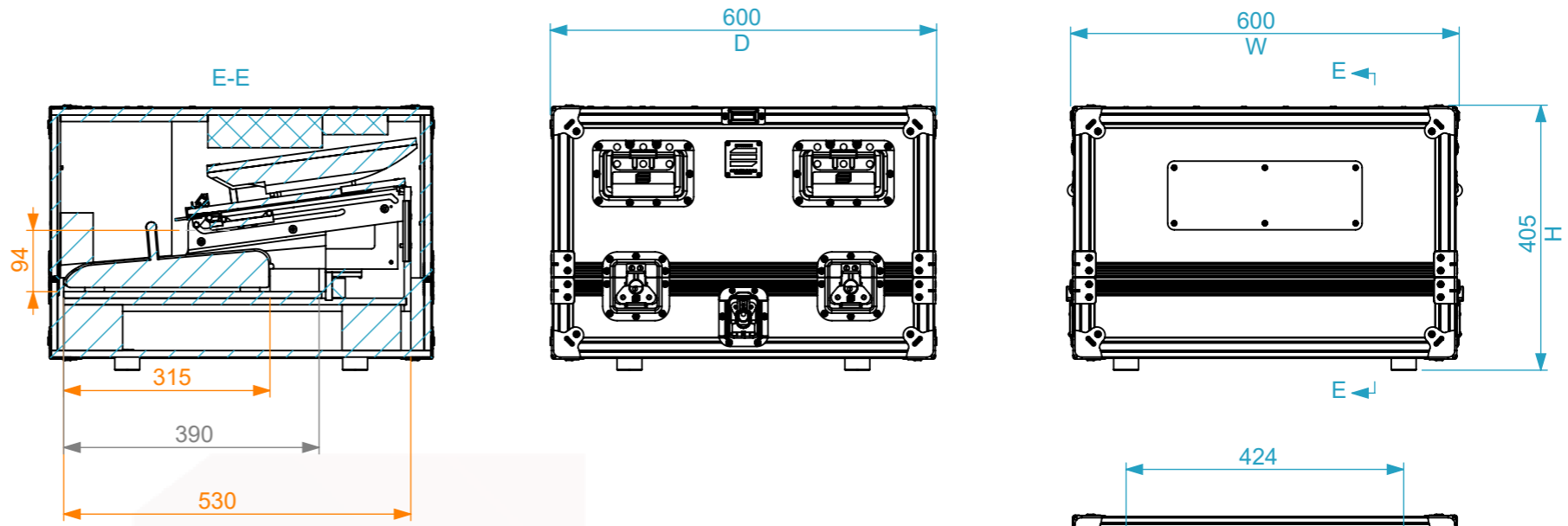

24" Touch Monitor
Max. Dimensions (WxDxH): 540x55x325

Recommended:
DELL P2418D

2U

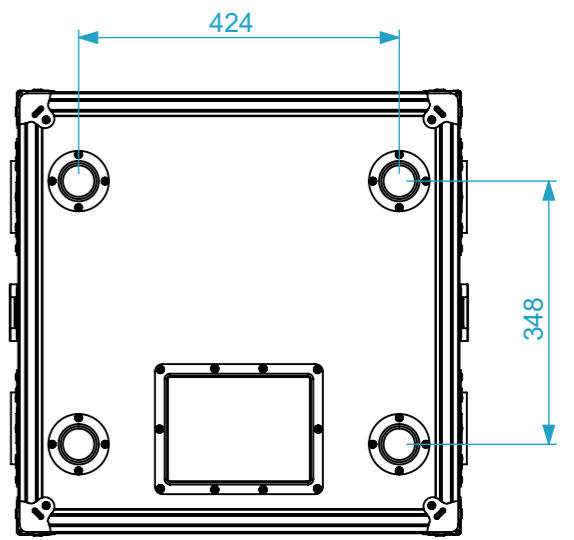

LED Backlit panel with logo (on both sides)

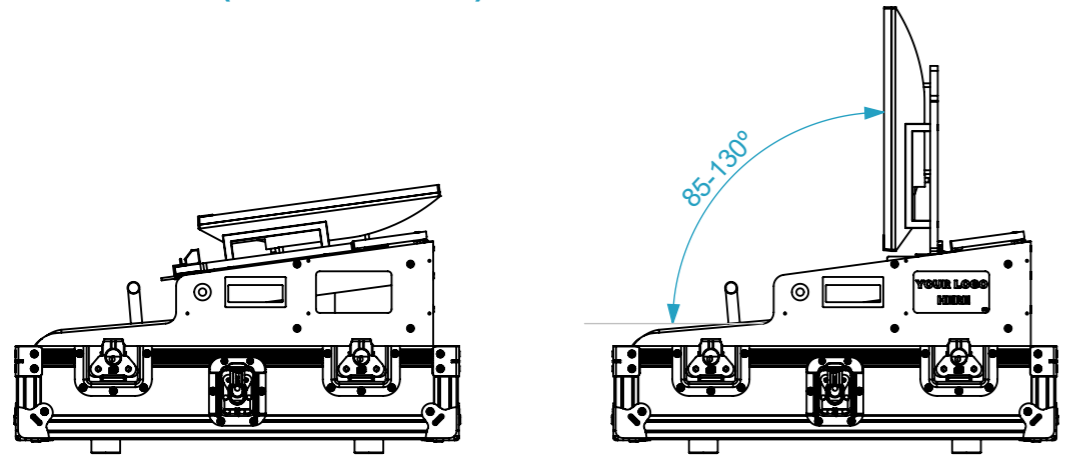
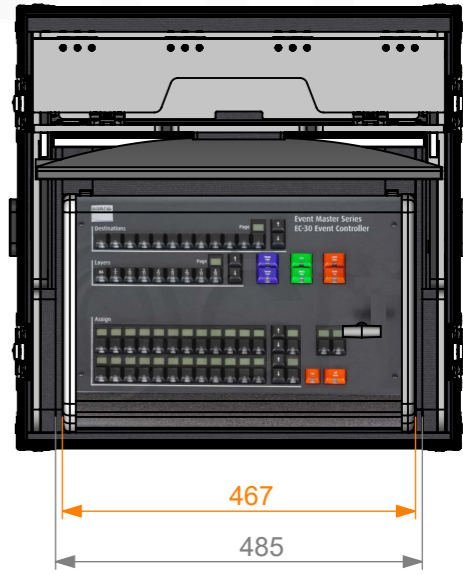

CLOSED

OPEN

General External Dimensions	
W	Width
D	Depth
H	Height

Name	Date	
Drawn by	CarlaSilva	25/08/2023
Reference	CS5.BRCEC3.02	
Scale	units in mm	general tolerance
1:10	DO NOT SCALE	0.8mm
FC PRO-5, Barco EC-30		



This drawing must not be copied or disclosed without consent of the owner



A3

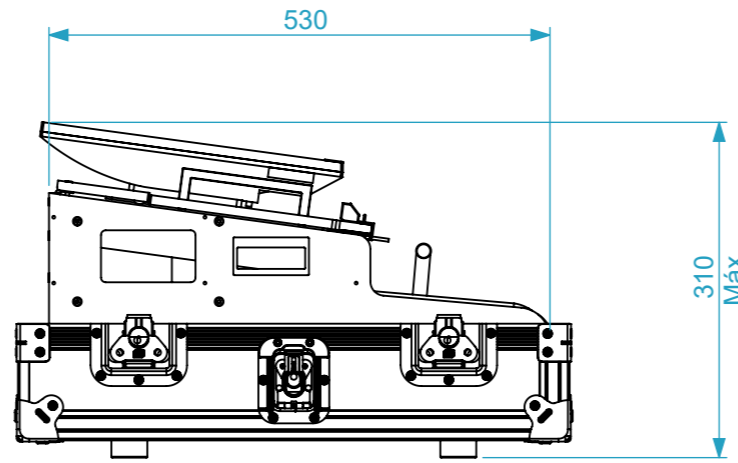
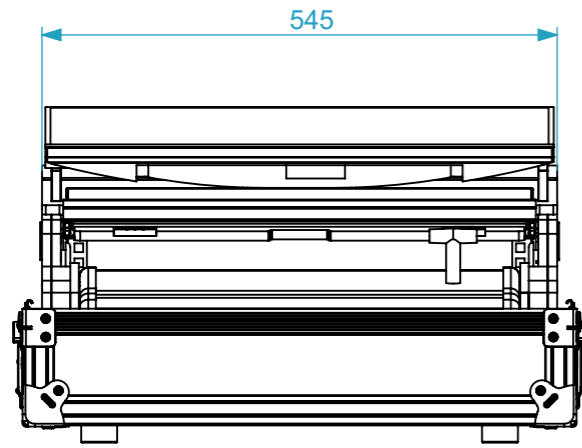

LED Lighting Bar (to illuminate the console)

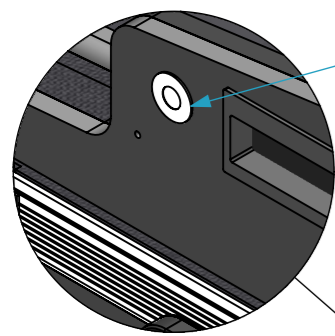
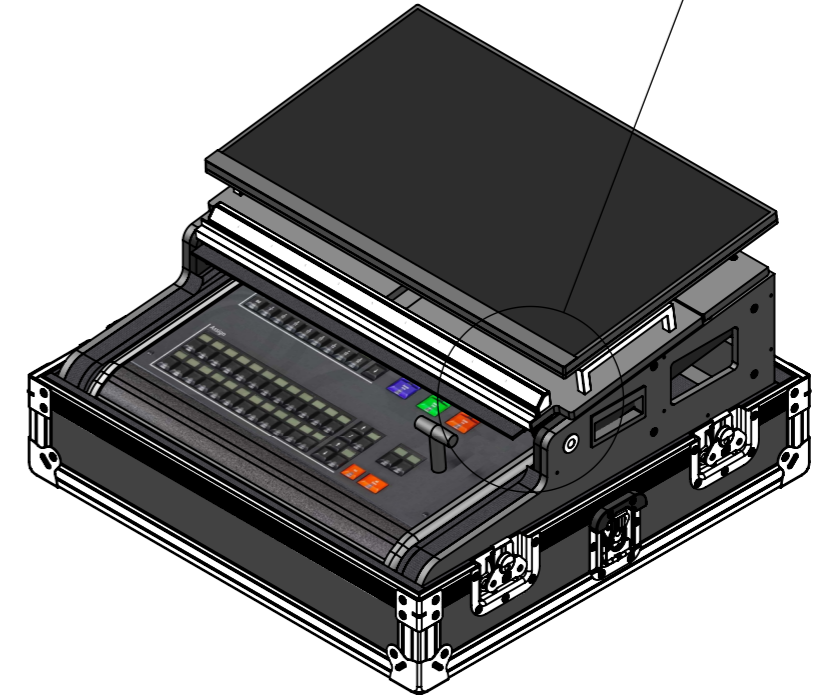
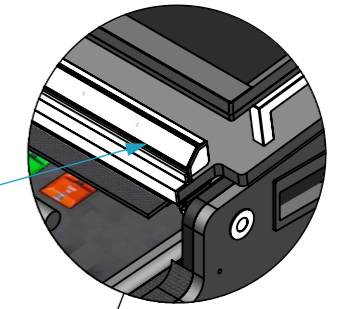

USB 3.0 Connector

Detent Torque Hinges

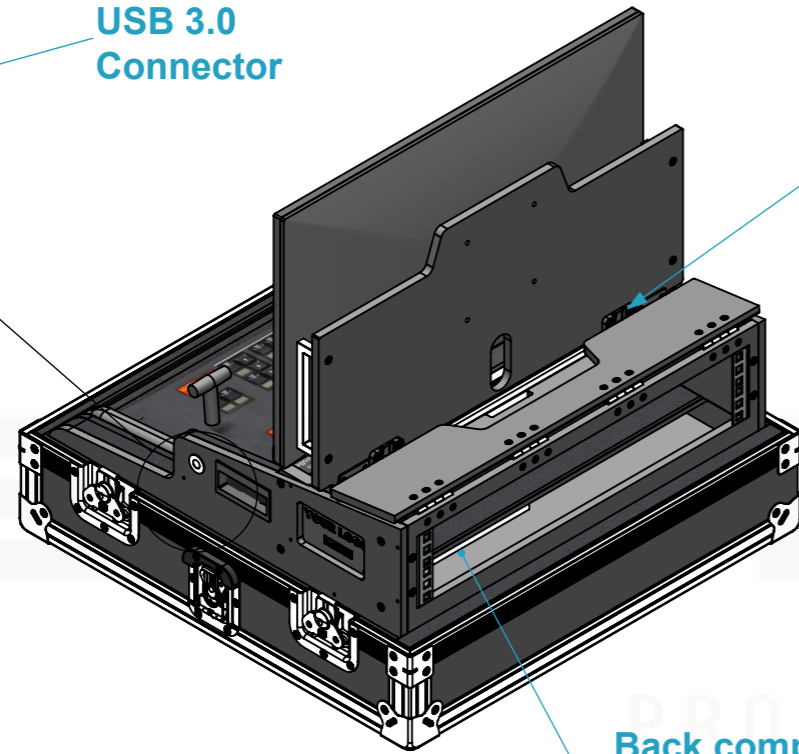

Back compartment for wiring and electrical connections.
Dimensions (WxDxH): 490x75x130

Sliding rail with

Handles to lift the system

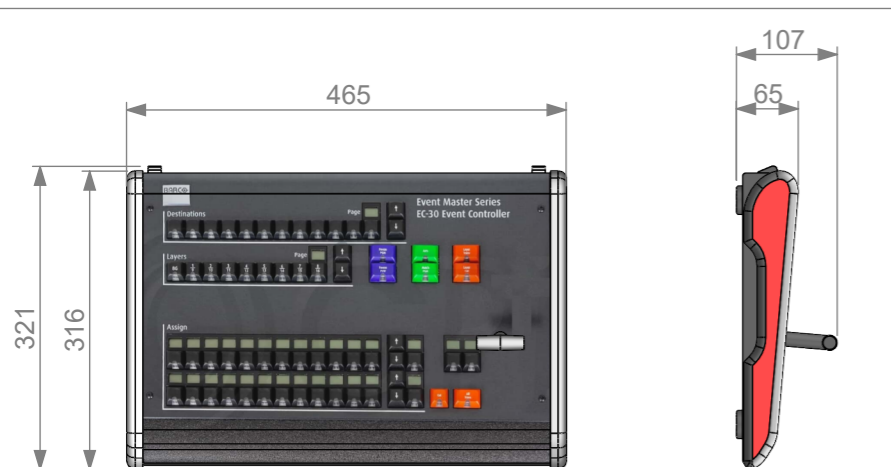
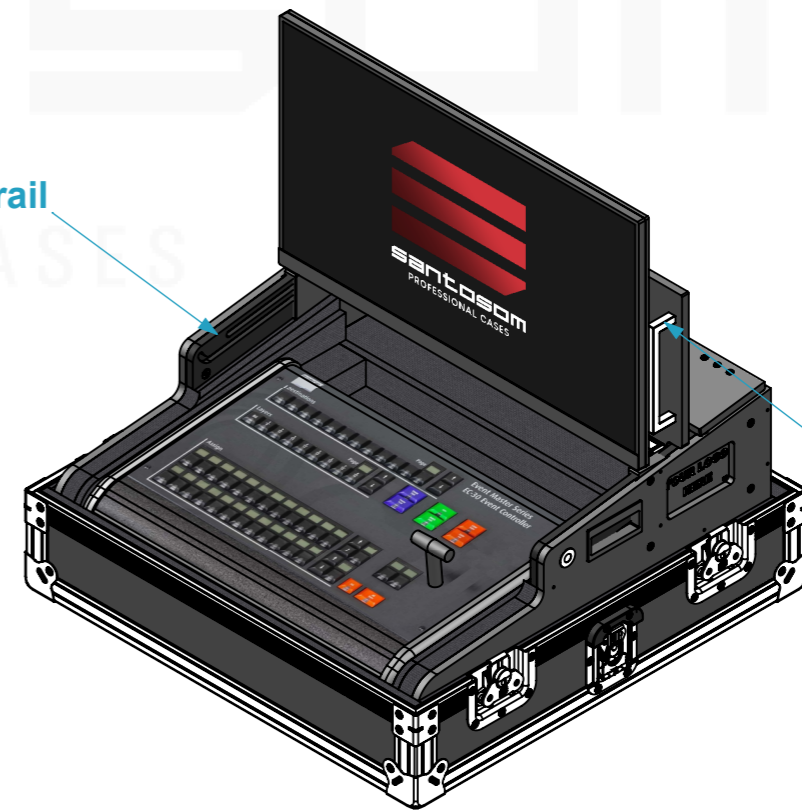

This drawing must not be copied or disclosed without consent of the owner

Drawn by	Name	Date
CarlaSilva	CarlaSilva	25/08/2023
Reference	CS5.BRCEC3.02	
Scale	units in mm	general tolerance
1:8	DO NOT SCALE	0.8mm
1st Angle projection	FC PRO-5, Barco EC-30	



A3