

Equipment	grandMA2 onPC Command Wing	
Width	Depth	Height
536	395	70
Weight	Approx. 6 Kg	
FC Weight	Approx. 48 Kg	
Wall Thickness	10mm	

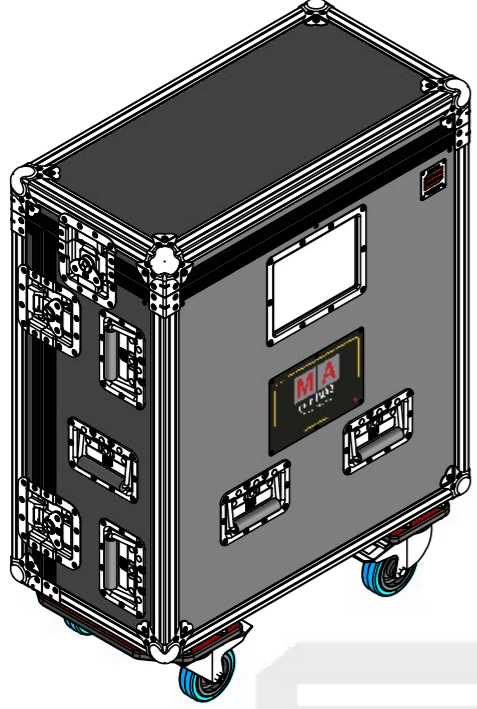

Plastic Feet

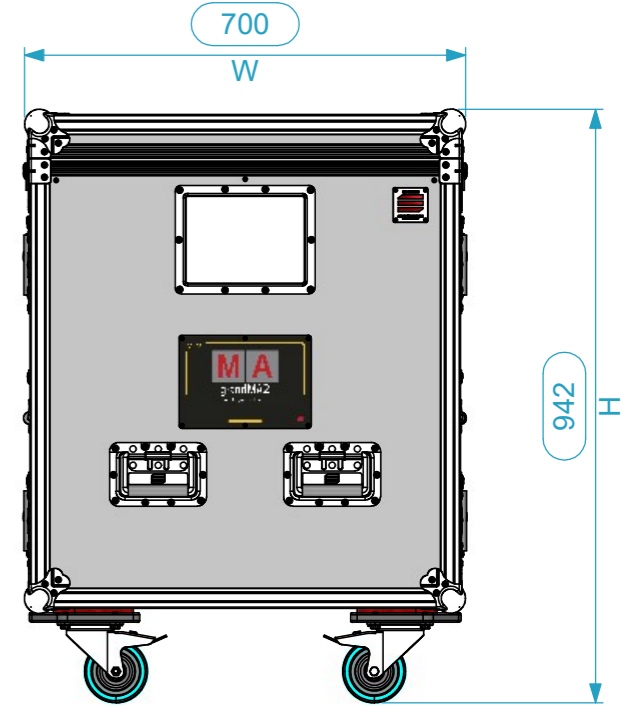
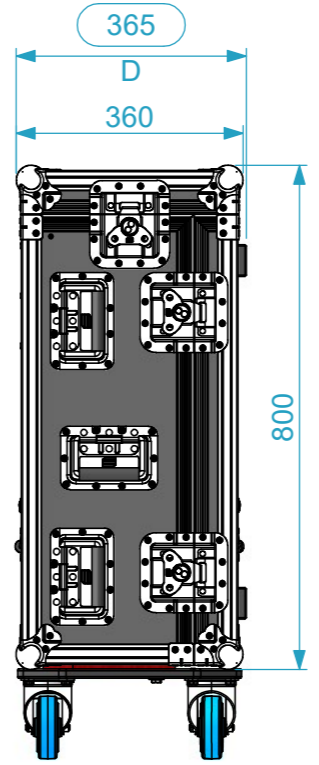
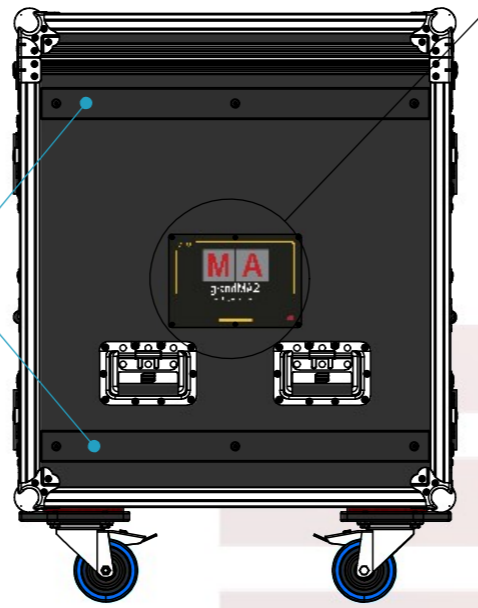

Handles (to lift the system)

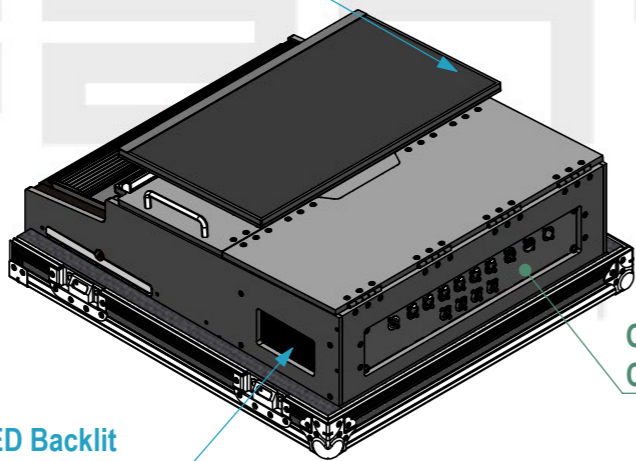

LED Backlit panel (decorative)

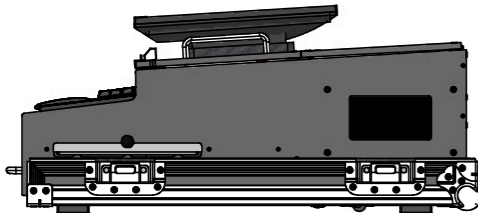

CLOSED

Optional 2U Connection panel: CST.L14.EU \ UK \ US

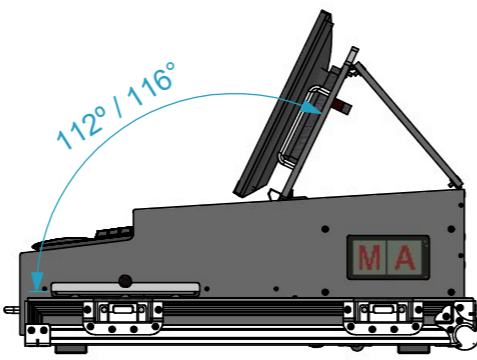

OPEN

22" / 24" Touch Monitor
Max. Dimensions (WxDxH): 540x55x320

Compartment for CPU, wiring and electrical connections. Dimensions (WxDxH): 550x250x170



Drawer for keyboard and mouse

Sliding mouse support

General External Dimensions	
W	Width
D	Depth
H	Height

Name	Date	
Drawn by	CarlaSilva	02/07/2024
Reference	CS5.MALMA2.02	
Scale	units in mm	general tolerance 0.8mm
1:12	DO NOT SCALE	
1st Angle projection	Flight case PRO-S, MA2 ONPC CMD WING	



This drawing must not be copied or disclosed without consent of the owner

A3

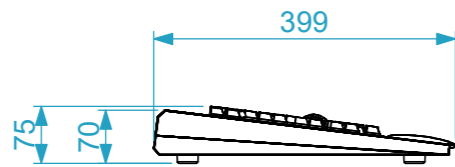
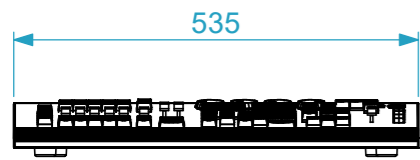

LED Lighting Dimmer Bar

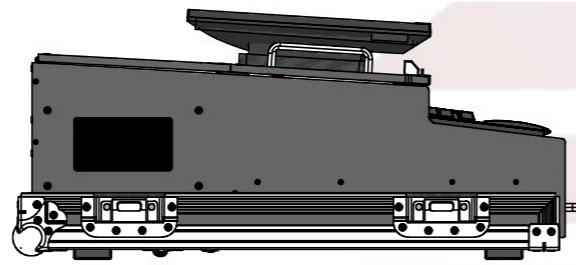
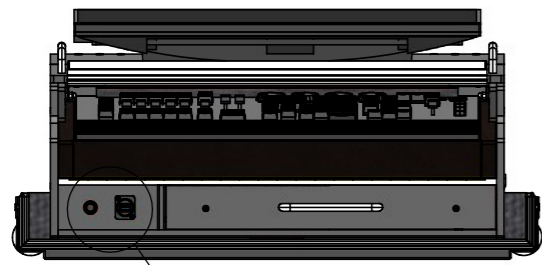
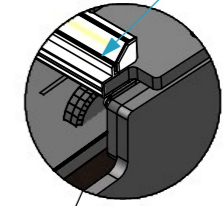

MA2 OnPC Command Wing

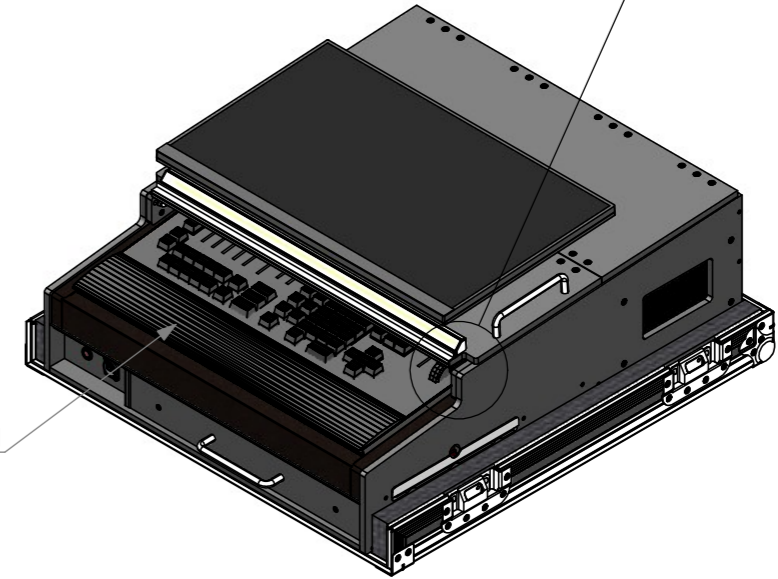

Aluminum profile with LED Lighting

LED Lighting Dimmer and USB 3.0 Connector

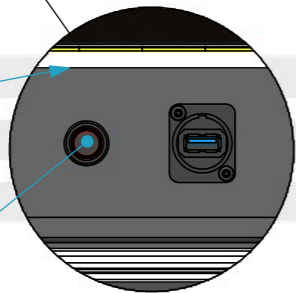

Sliding rail with 2 stop positions

Black leather cushioning

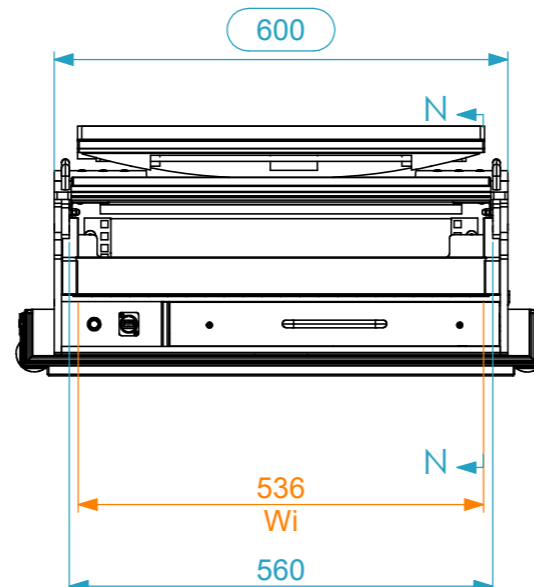
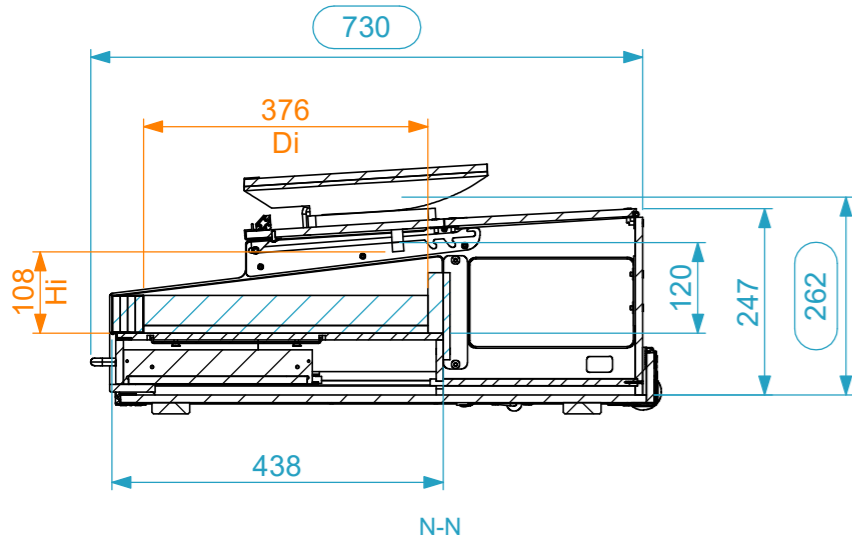

	Name	Date
Drawn by	CarlaSilva	02/07/2024
Reference	CS5.MALMA2.02	
Scale	units in mm	general tolerance 0.8mm
1:10	DO NOT SCALE	
1st Angle projection	Flight case PRO-S, MA2 ONPC CMD WING	



This drawing must not be copied or disclosed without consent of the owner

A3