

Equipment	Barco EC 30	
Width	Depth	Height
466	321	106
Equipment Weight	Approx. 3.18 Kg	
Internal Dimensions		
Width	Depth	Height
Flight case Weight	Approx. 66 Kg	
Wall Thickness	10mm	

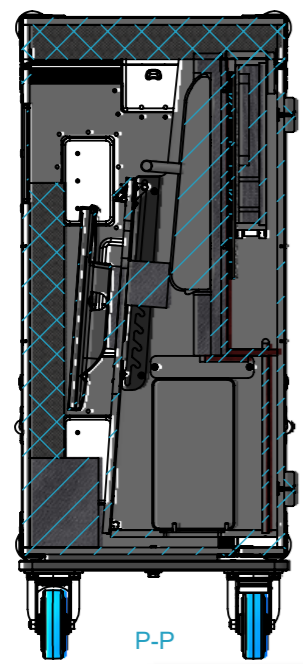

Plastic feet

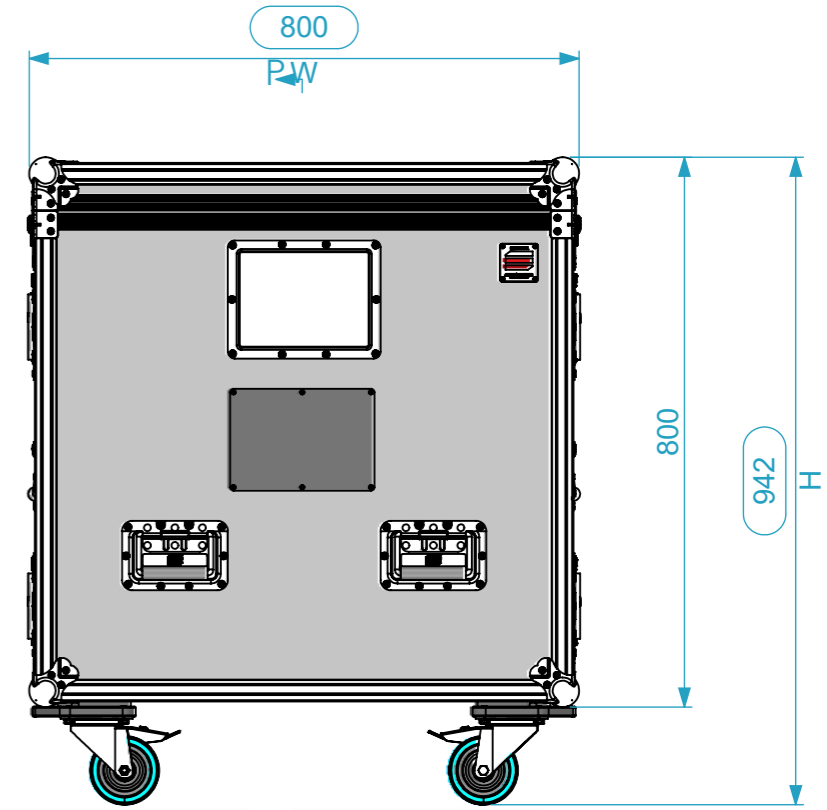
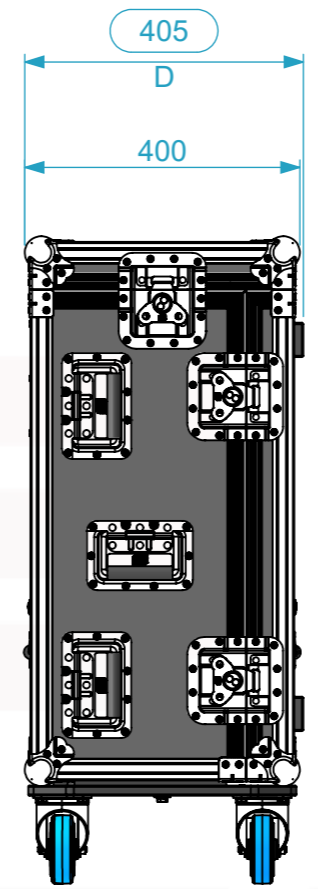
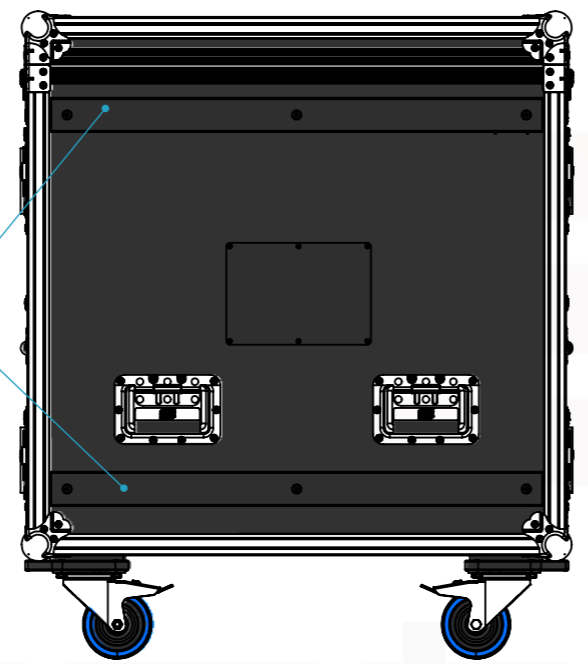

Mixing Console Compartment

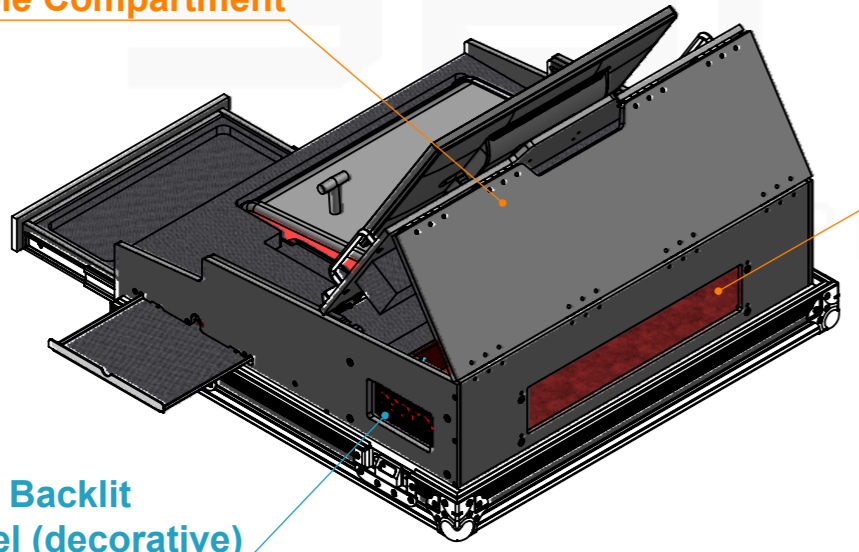

Optional 2U Connection panel: CST.

LED Backlit panel (decorative)

Drawer for keyboard and mouse

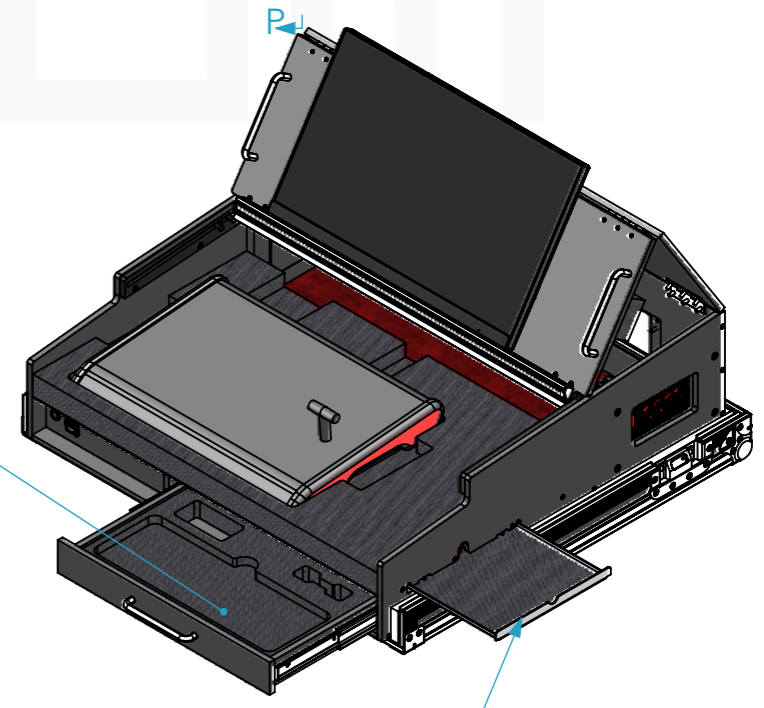

Sliding mouse support

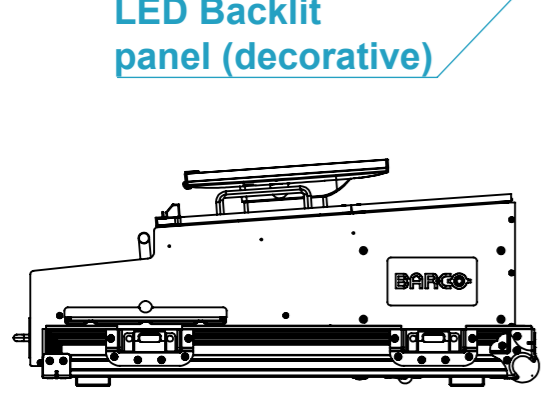

Closed

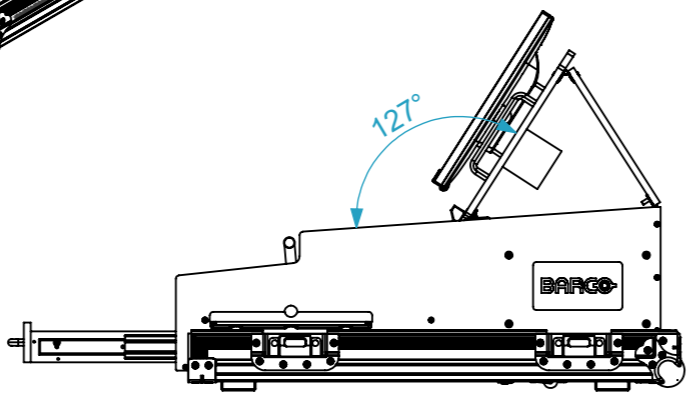

Open

This drawing must not be copied or disclosed without consent of the owner

Drawn by	Name	Date
CarlaSilva	CarlaSilva	29/06/2023
Reference	CS5.BRCEC3.02	
Scale	units in mm	general tolerance
1:1	DO NOT SCALE	0.8mm
1st Angle projection	Flight case PRO-5 Barco EC 30	



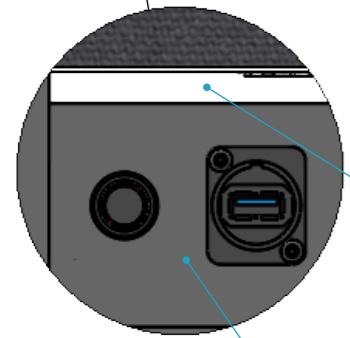
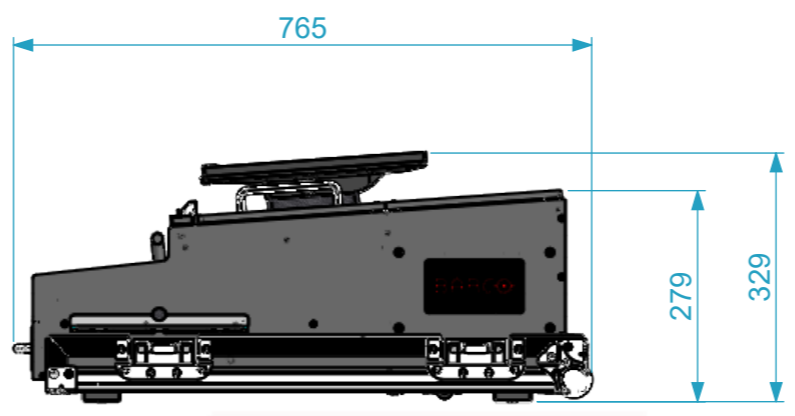
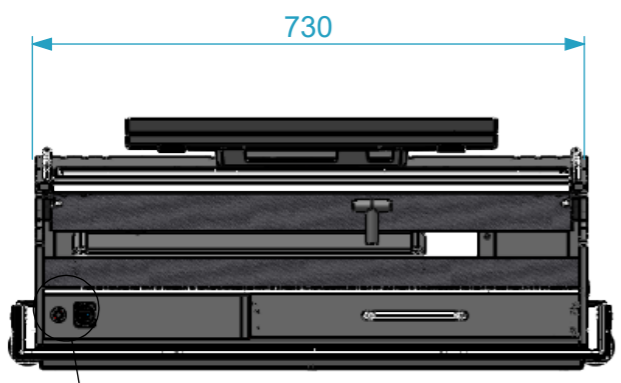

Aluminium profile with LED Lighting

Recessed panel with LED Lighting Dimmer and one USB 3.0 Connector

Handles (to lift the system)

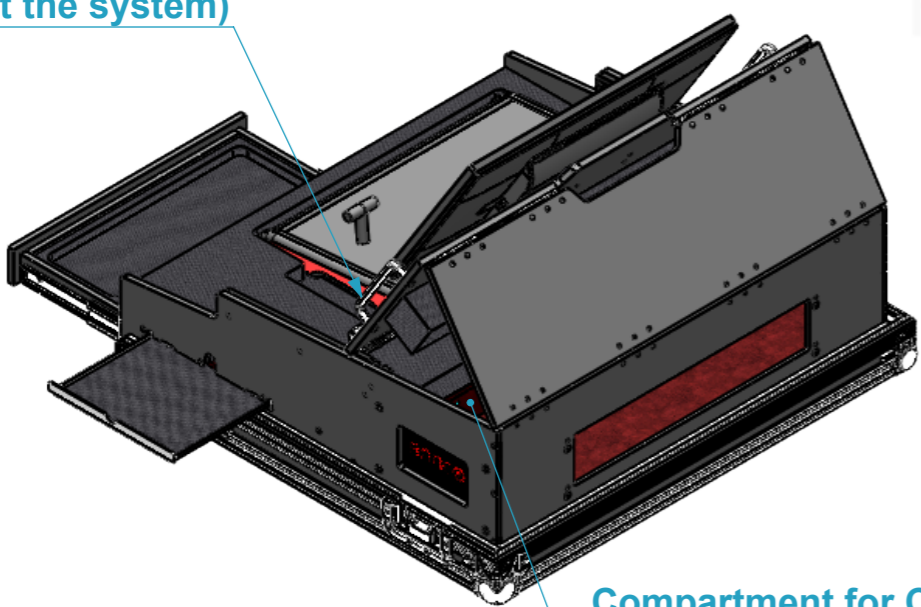

Compartment for CPU wiring and electrical connections. Dimensions (WxDxH): 600x250x200mm

Sliding rail with 3 stop positions

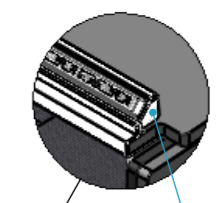
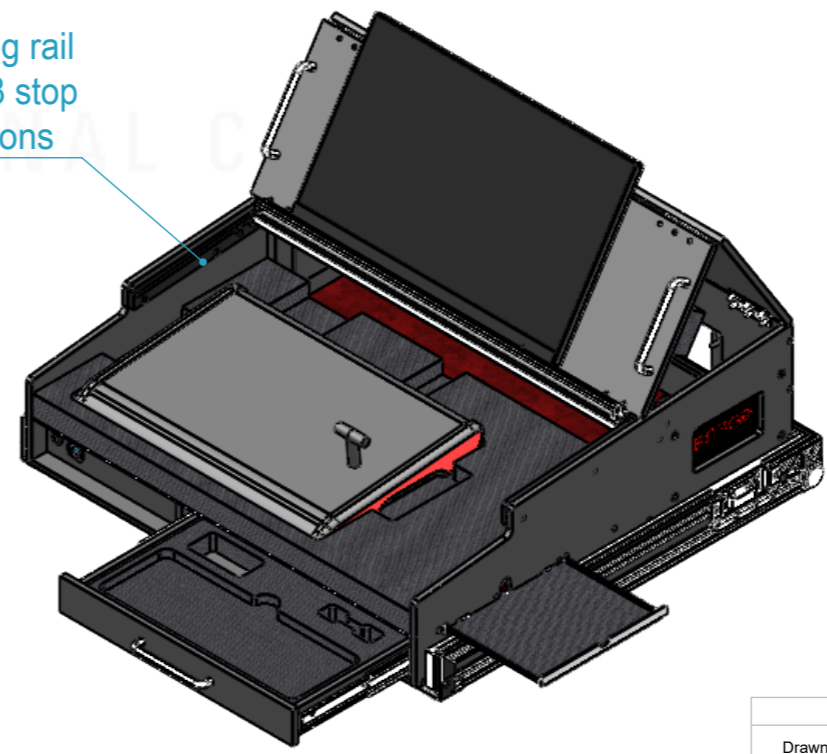

LED Lighting Bar

BARCO EC-30

A3

This drawing must not be copied or disclosed without consent of the owner

Drawn by	Name	Date
CarlaSilva	CarlaSilva	29/06/2023
Reference	CS5.BRCEC3.02	
Scale	units in mm	general tolerance
1:10	DO NOT SCALE	0.8mm
1st Angle projection	Flight case PRO-5 Barco EC 30	

