

Equipment			ETC Eos Ti		
Width	Depth	Height			
1003	667	370			
Weight	Approx. 38.5 Kg				
Internal Dimensions					
Width	Depth	Height			
1010	750	149			
Weight	Approx. 86 Kg				
Wall Thickness		10mm			

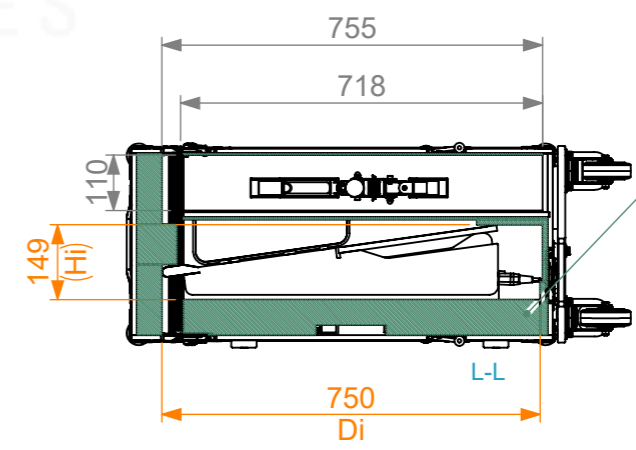
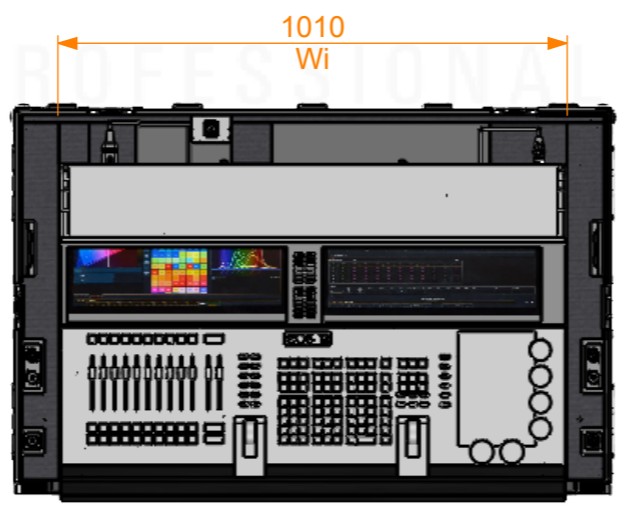
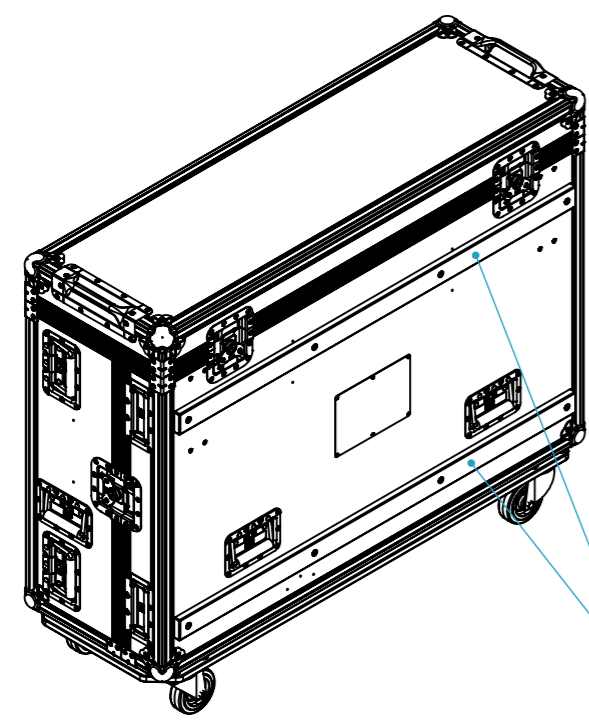
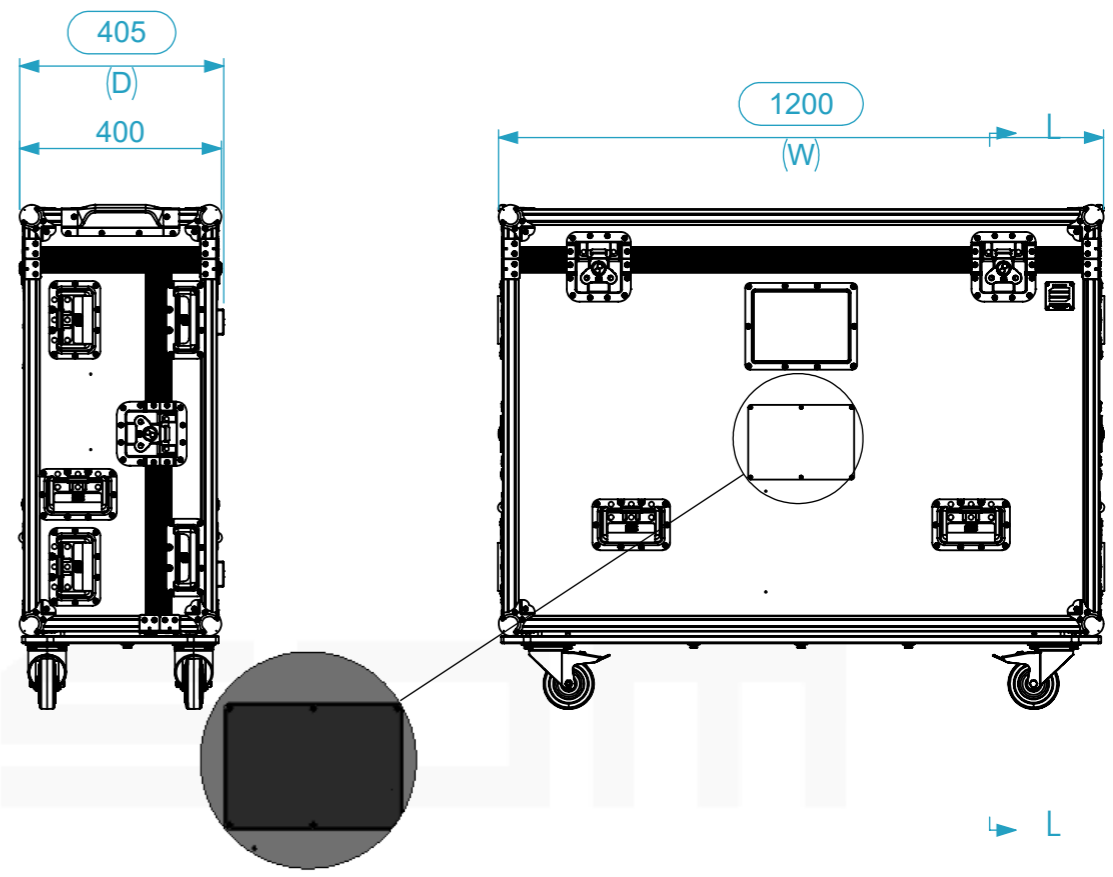
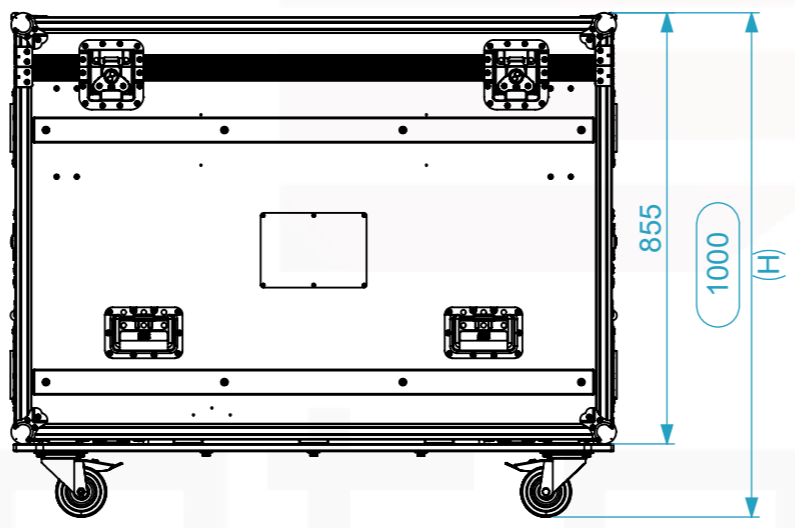
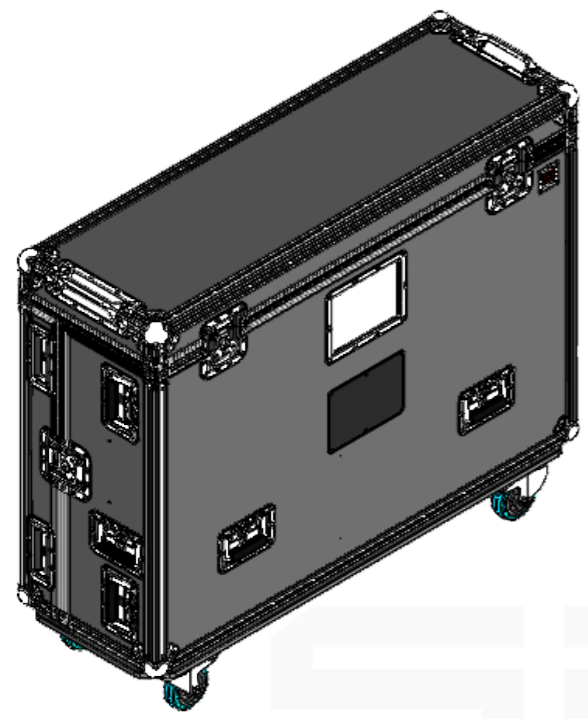
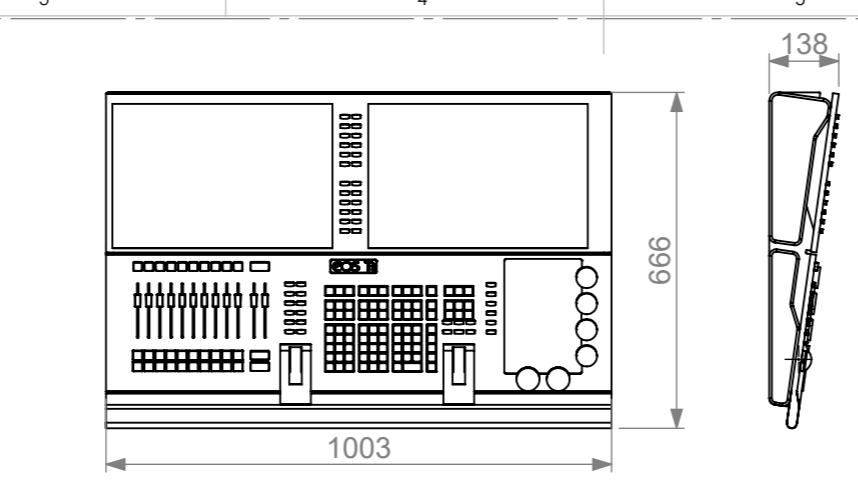

HD Foam

Wear resistant PE500 plastic feet

General External Dimensions	
W	Width
D	Depth
H	Height
Usable Inner Dimensions	
Wi	Inside Width
Di	Inside Depth
Hi	Inside Height
Wood Inner Dimensions	
WWi	Wood Inside Width
WDi	Wood Inside Depth
WHi	Wood Inside Height

Name	Date
rita.monteiro	03/06/2026
Reference CS3A.ETCI	
Scale 1:15	units in mm DO NOT SCALE
general tolerance 0.8mm	
Flight case PRO-32 ETC EOS TI	



This drawing must not be copied or disclosed without consent of the owner



A3

Slots for Swivel Arm supports
Left an Right of the case

XLR connector

USB-C

Net Bag For accessories

Velcro Straps

Compartment for Monitor up to 27" (with adjustable shelf lined with eggbox foam)

Compartment for two Swivel Arm (with adjustable shelf)

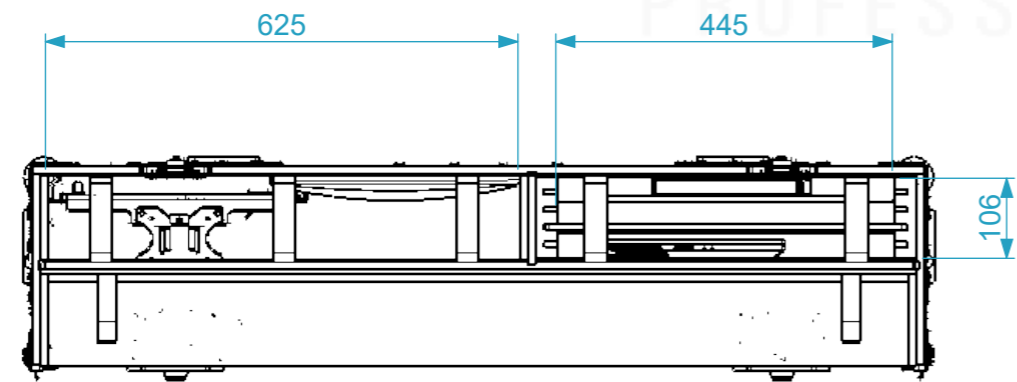

Equipments	Not included
Accessories	Optional
Accessories	Included

	Name	Date
Drawn by	rita.monteiro	03/06/2026
Reference	CS3A.ETCI	
Scale	units in mm	general tolerance
1:10	DO NOT SCALE	0.8mm
1st Angle projection	Flight case PRO-32 ETC EOS II	



This drawing must not be copied or disclosed without consent of the owner

A3

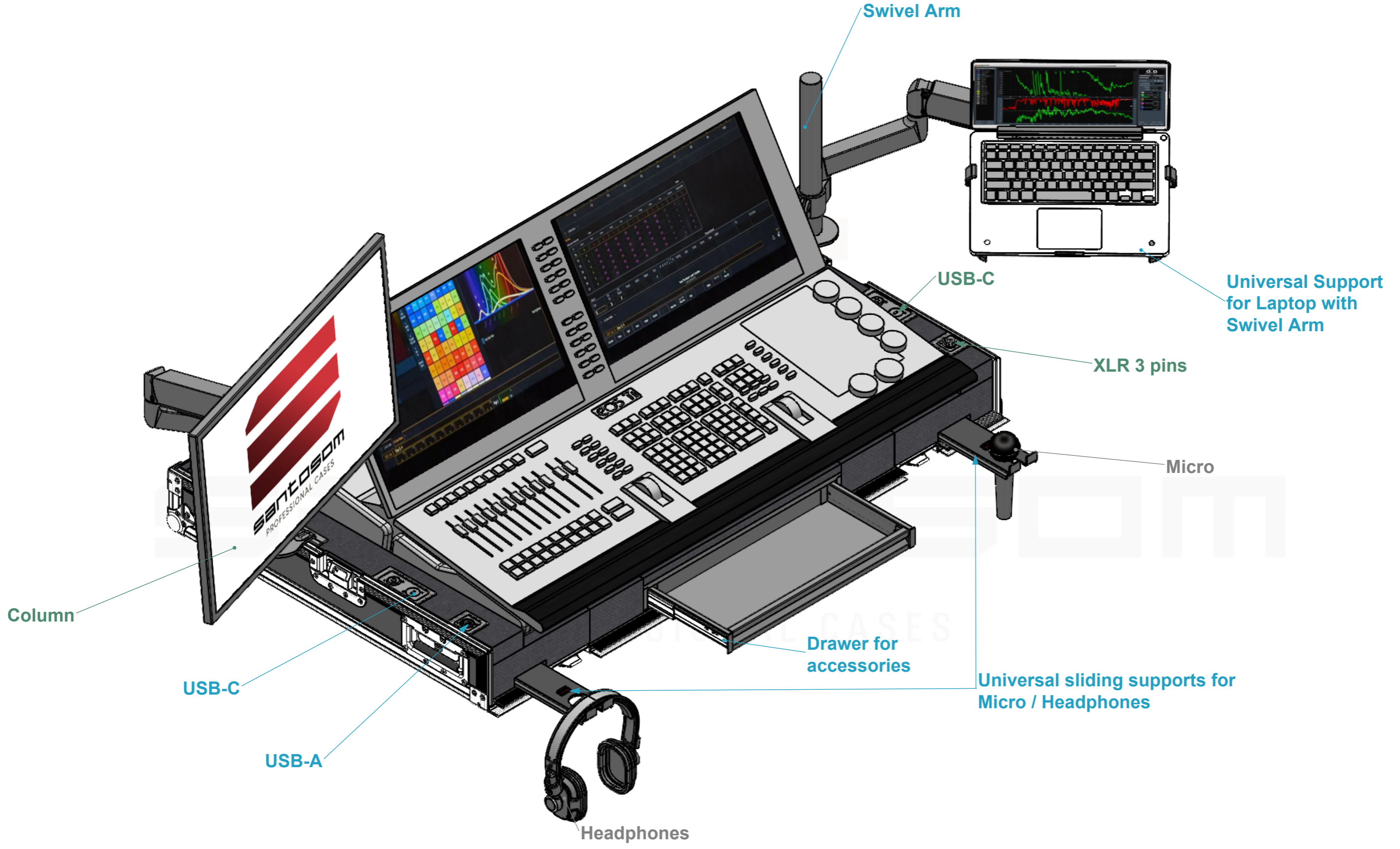

Column

USB-C

USB-A

Headphones

Drawer for accessories

Universal sliding supports for Micro / Headphones

Micro

XLR 3 pins

USB-C

Universal Support for Laptop with Swivel Arm

Swivel Arm

Equipments	Not included
Accessories	Optional
Accessories	Included

A3 This drawing must not be copied or disclosed without consent of the owner

Drawn by	rita.monteiro	Date	03/06/2026
Reference	CS3A.ETCTI		
Scale	1:6	units in mm	general tolerance 0.8mm
		DO NOT SCALE	
		Flight case PRO-32 ETC EOS II	



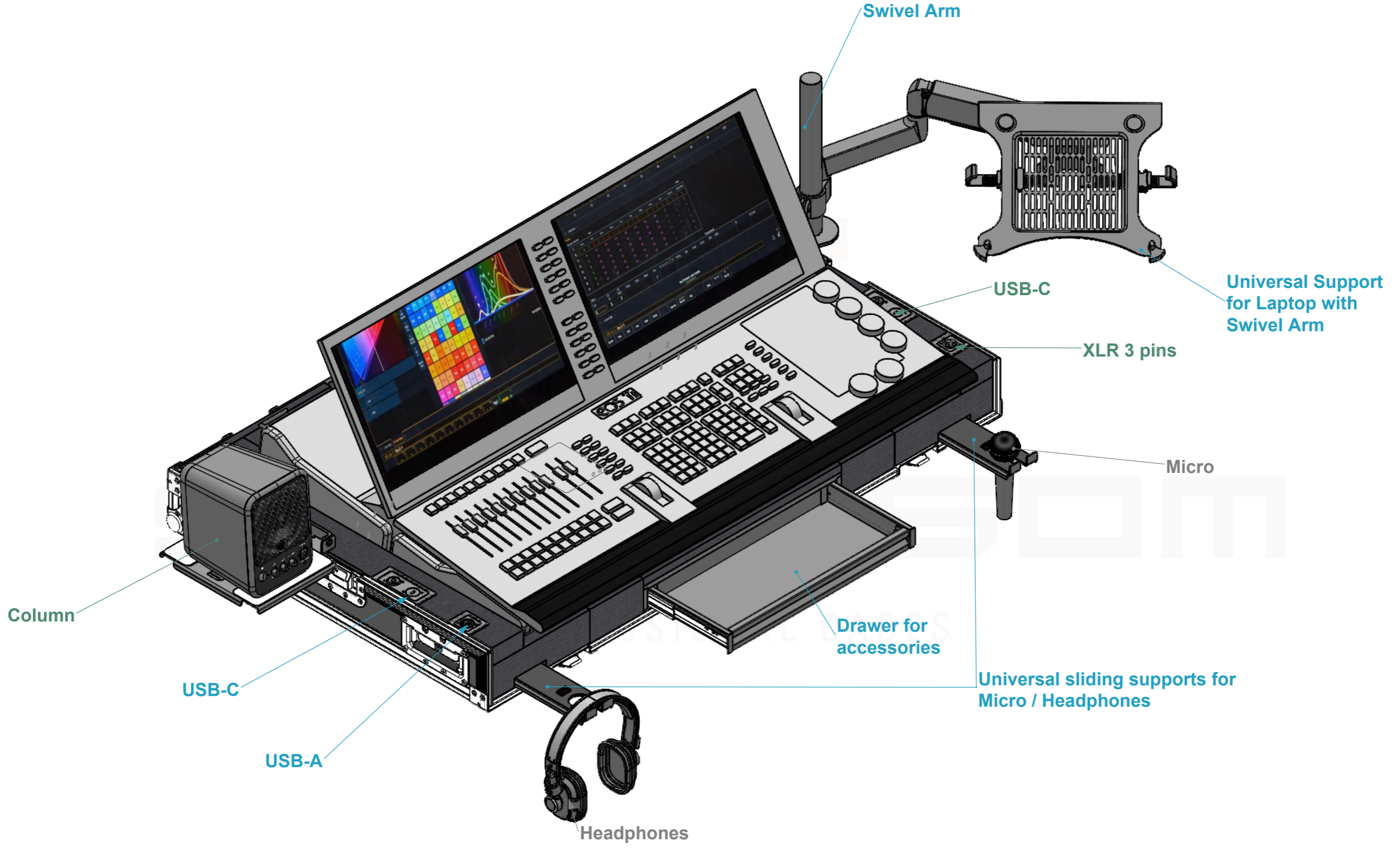

Equipments	Not included
Accessories	Optional
Accessories	Included

A3 This drawing must not be copied or disclosed without consent of the owner

Drawn by	Name	Date
rita.monteiro	rita.monteiro	03/06/2026
Reference	CS3A.ETCI	
Scale	units in mm	general tolerance
1:6	DO NOT SCALE	0.8mm
1st Angle projection	Flight case PRO-32 ETC EOS II	

