

Interior dimensions		
Width	Depth	Height
550	538	460/7Un
Weight	Approx. 33 Kg	
Wall Thickness	10mm	

REVISIONS				
ZONE	REV.	DESCRIPTION	DATE	APPROVED
-	-	Final Drawing	18/03/2014	Daniel Lopes

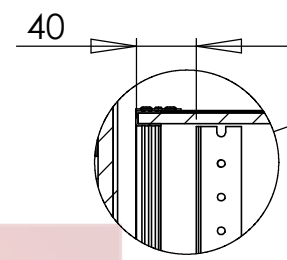
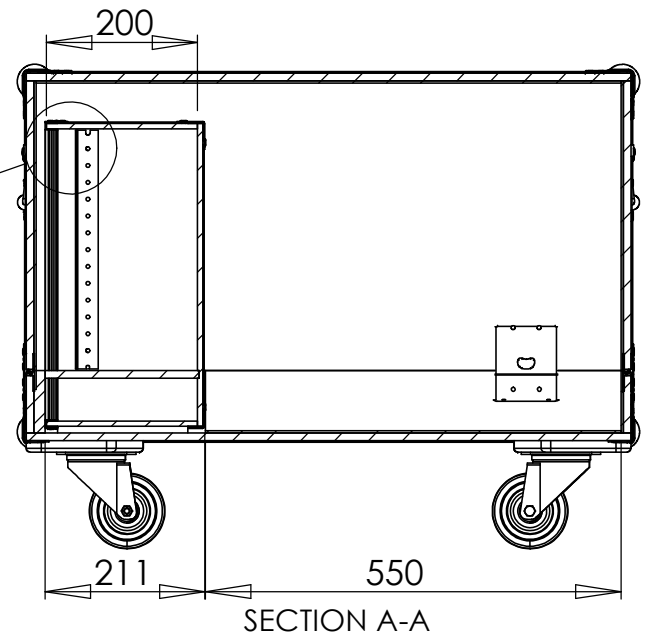
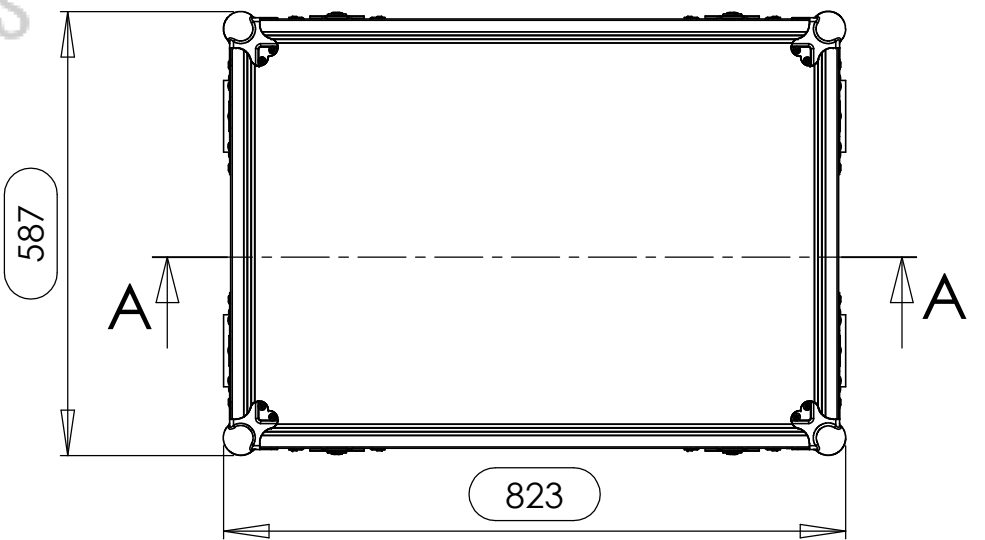
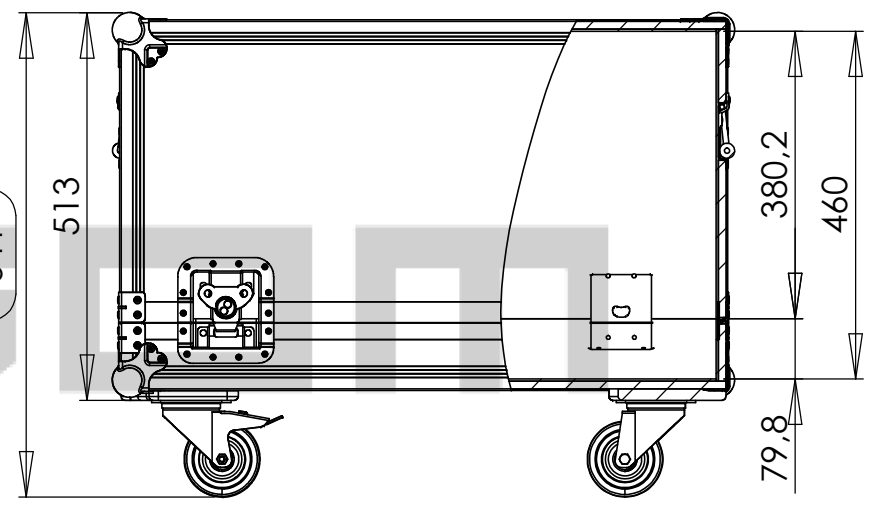
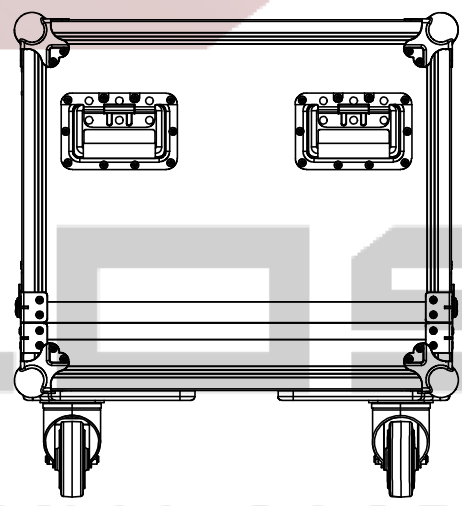
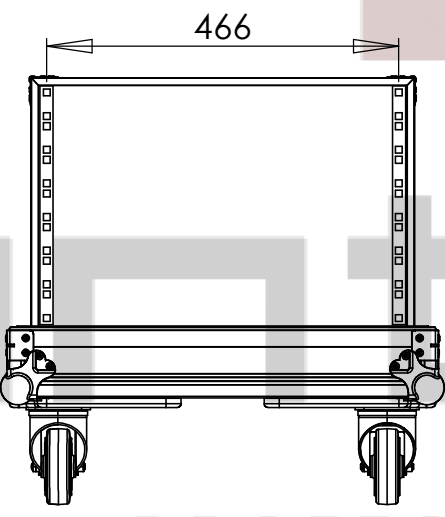
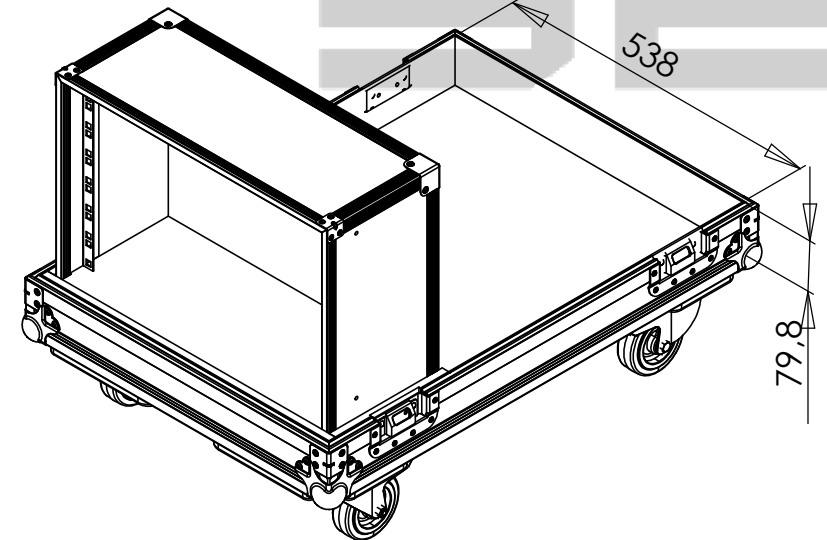
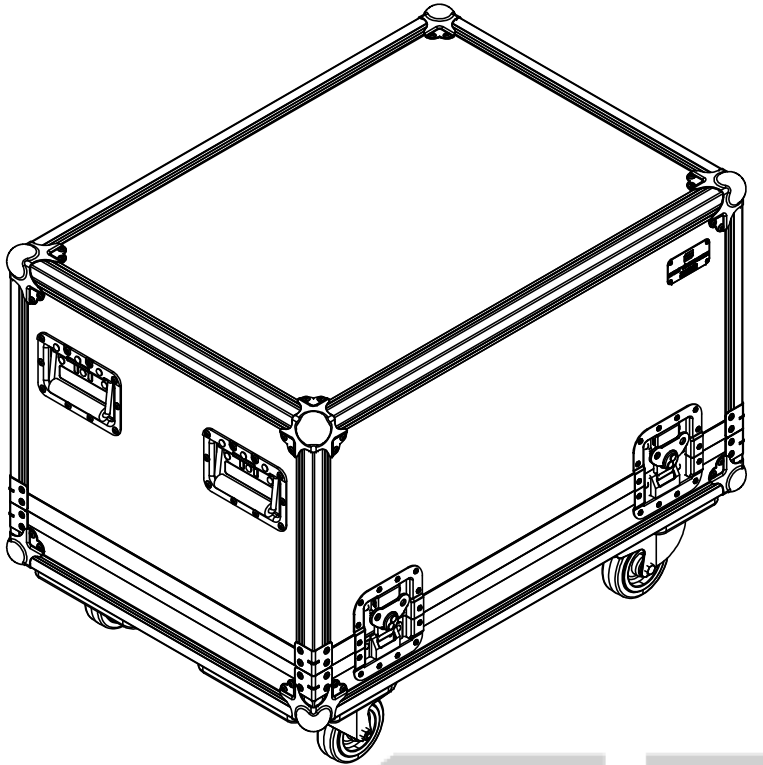

Hardware		
Qty	Ref.	Description
8	410429	Heavy Duty Ball Corner
8	40403	Large corner bracket f. 35mm case angle
2	RODA.100T	Swivel castor Ø100mm with brake
2	RODA.100	Swivel castor Ø100 mm
4	172531	Large butterfly V3 with 'push-back' function
4	34082	Recessed sprung handle medium model

This drawing must not be copied or disclosed without consent of the owner

Drawn by	DanielLopes	Date	19-03-2014
Reference	CABLE.0251R		
Scale	1:10	units in mm	general tolerance 0.8mm
		DO NOT SCALE	
		FC, P/ ENROLADOR 70250 + RACK MADIRA 7UN, RODAS	

