

Exterior dimensions

Width	Depth	Height
757	568	1225
Weight	Approx. 43 Kg	
Wall Thickness	10mm	

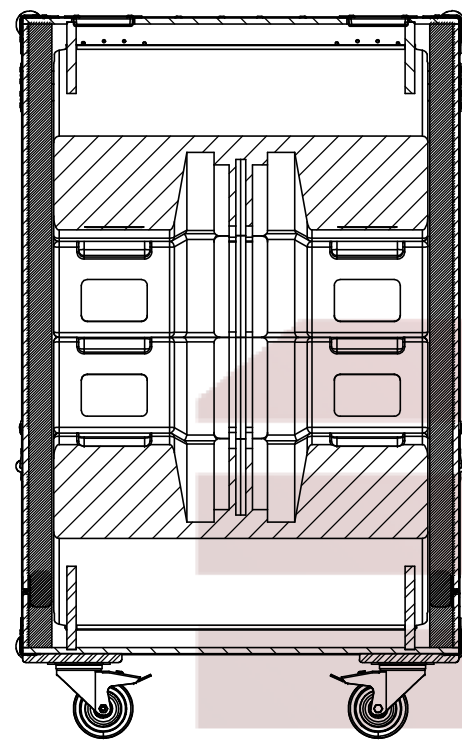

SECTION A-A

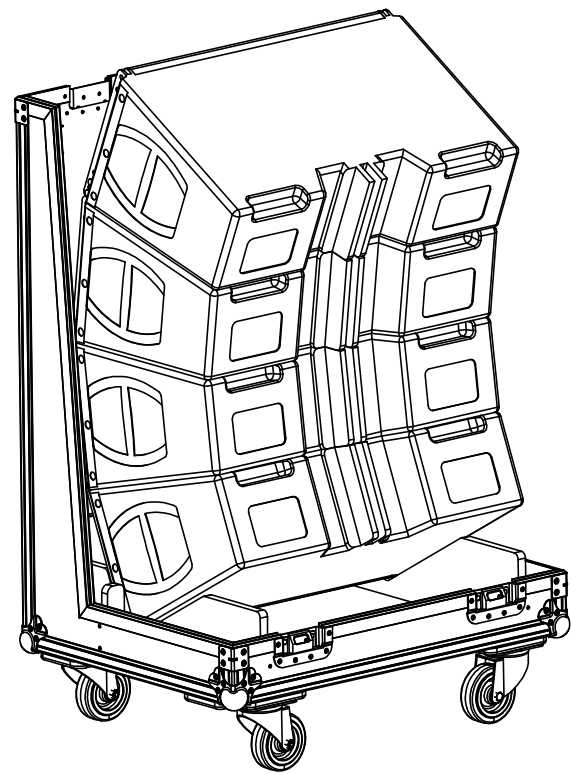
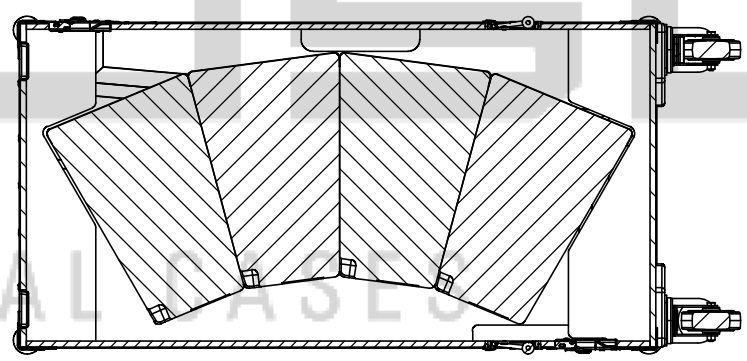
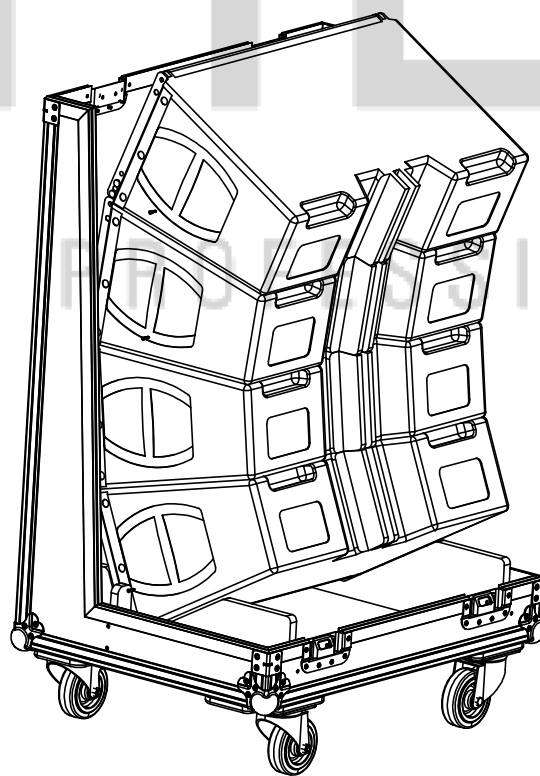
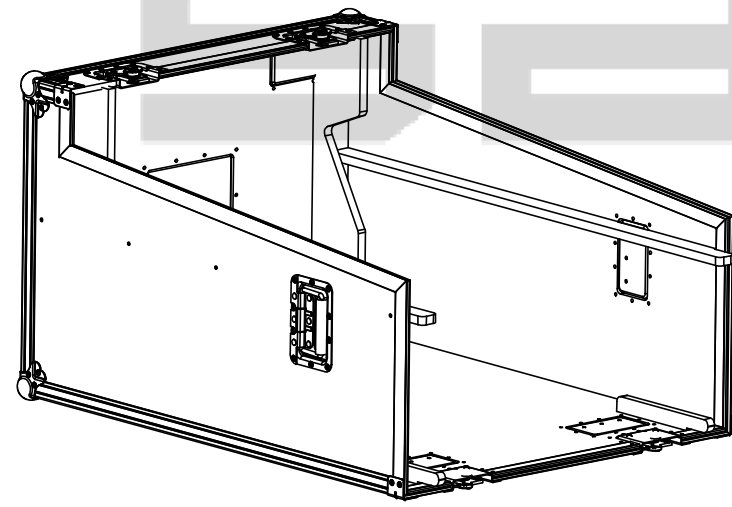
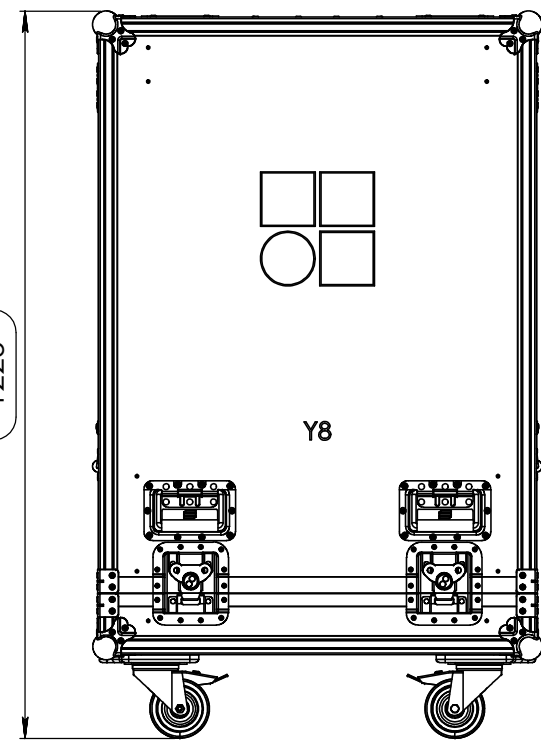
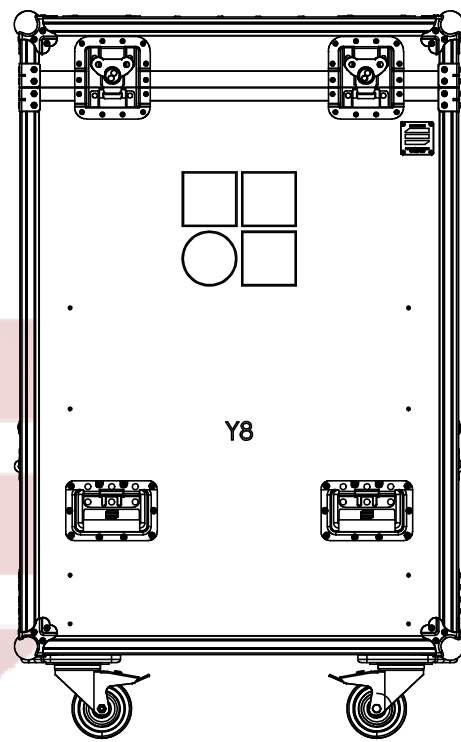

SECTION B-B

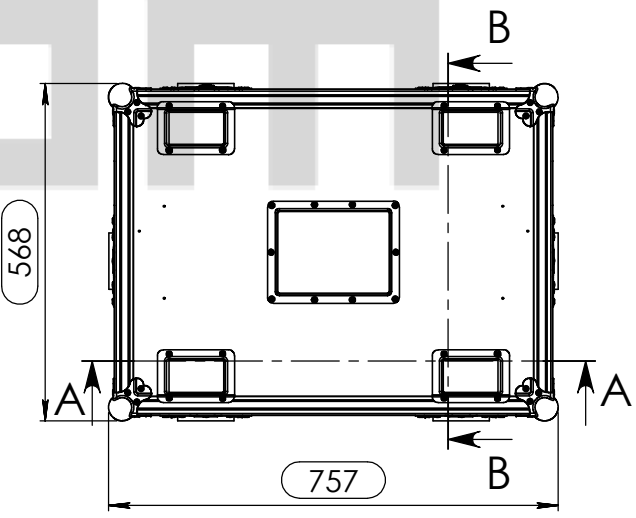

Hardware		
Qty	Ref.	Description
8	4101	Heavy Duty Ball Corner
8	40403	Large corner bracket f. 35mm case angle
2	RODA.100T	Swivel castor Ø100mm with brake
6	34082	Recessed sprung handle medium model
4	172531	Large butterfly V3 with 'push-back' function
2	RODA.100	Swivel castor Ø100 mm
4	38082	Castor dish deep zinc plated
1	88001D	Dish for 88001 Tour Label

Drawn by	projects	Date	22/08/2016
Reference	CABINET.946R		
Scale	1:9	general tolerance	0.8mm
1st Angle projection	FC. 4X D&B Y8 RODAS		

This drawing must not be copied or disclosed without consent of the owner

