

Interior dimensions

Width	Depth	Height
345	367	600
Weight	Approx. 28 Kg	
Wall Thickness	10mm	

REVISIONS

ZONE	REV.	DESCRIPTION	DATE	APPROVED
-	-	Final Drawing	06/11/2015	Carlos Rodrigues

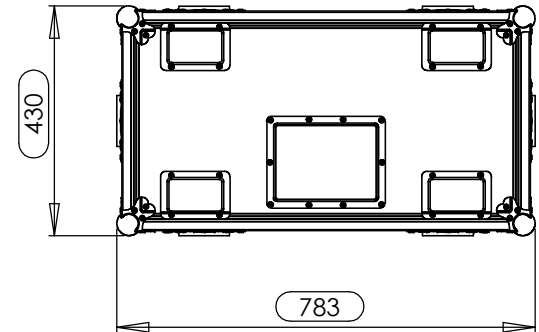
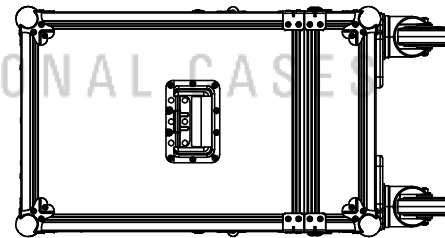
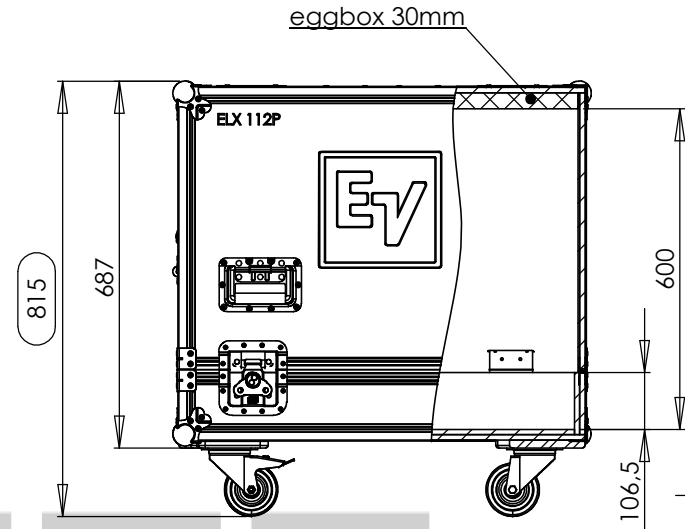
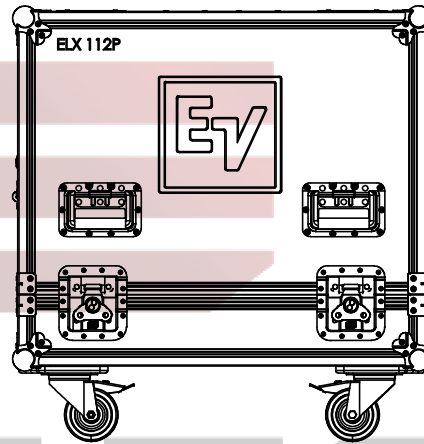
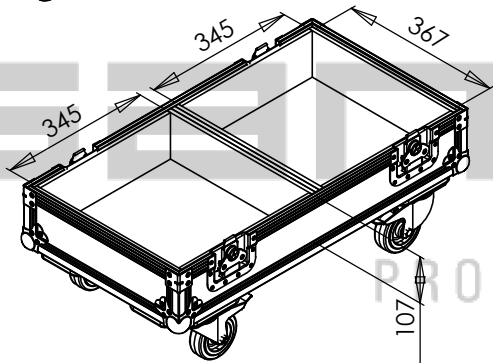
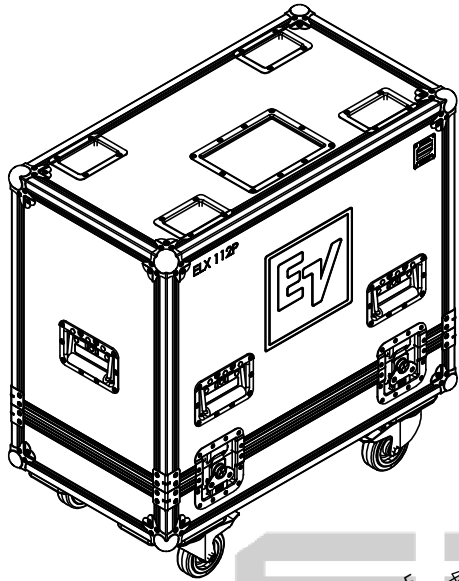

Hardware

Qty	Ref.	Description
8	410429	Ball Corner large three-leg cranked 35 mm 9 holes
8	40403	Large corner bracket f. 35mm case angle
6	34082	Recessed sprung handle medium model
1	88001D	Dish for 88001 Tour Label
4	38082	Castor dish deep zinc plated
2	RODA.100T	Swivel castor Ø100mm with brake
2	RODA.100	Swivel castor Ø100 mm
4	172531	Large butterfly V3 with 'push-back' function

This drawing must not be copied or disclosed without consent of the owner



Scale
1:10

units in mm
DO NOT SCALE
general tolerance
0.8mm

Reference
CABINET.939

FC. 2 ELECTRO-VOICE
ELX 112P, RODAS

Name
projects
Date
06/11/2015

