

Interior dimensions		
Width	Depth	Height
240	240	400
Weight	Approx. 29 Kg	
Wall Thickness	10mm	

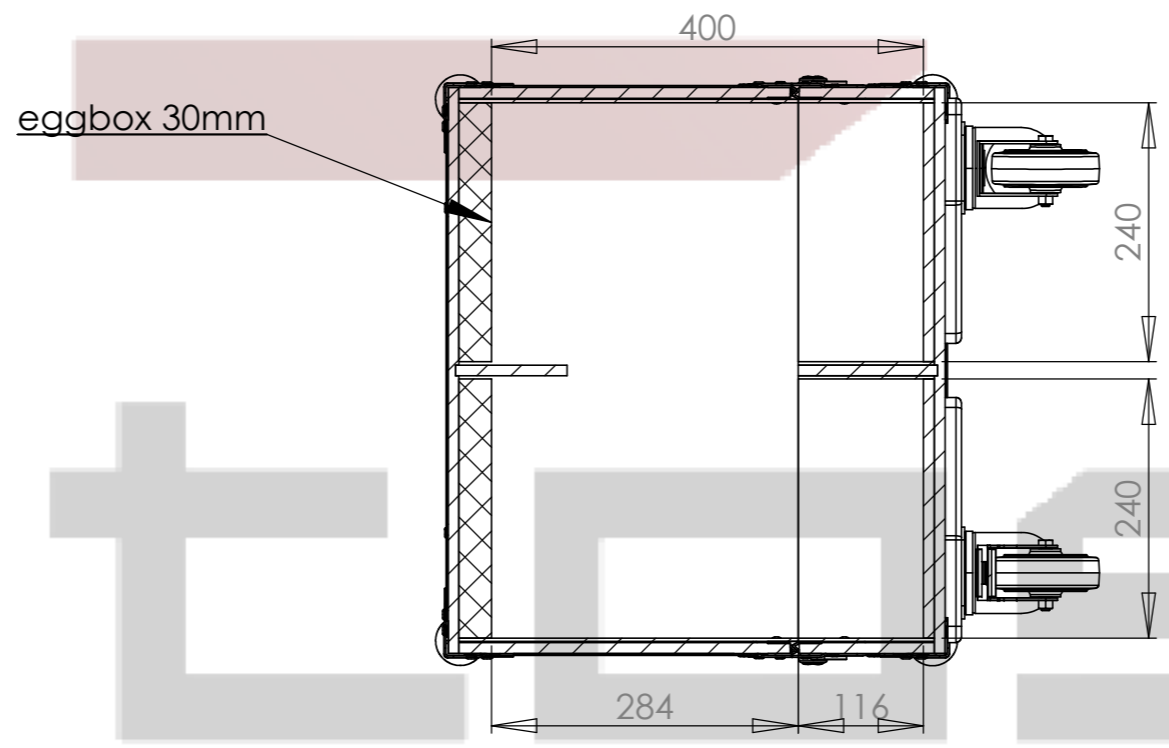

SECTION B-B

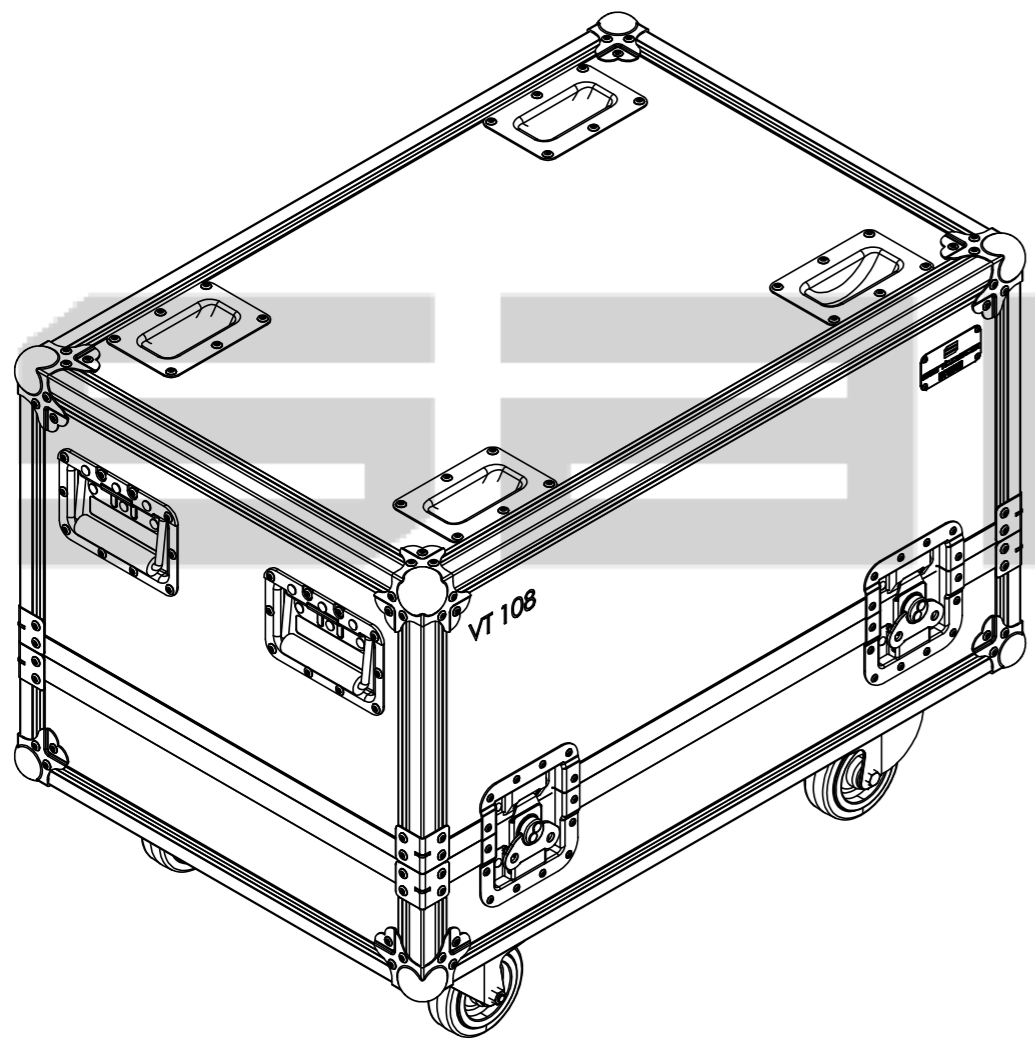
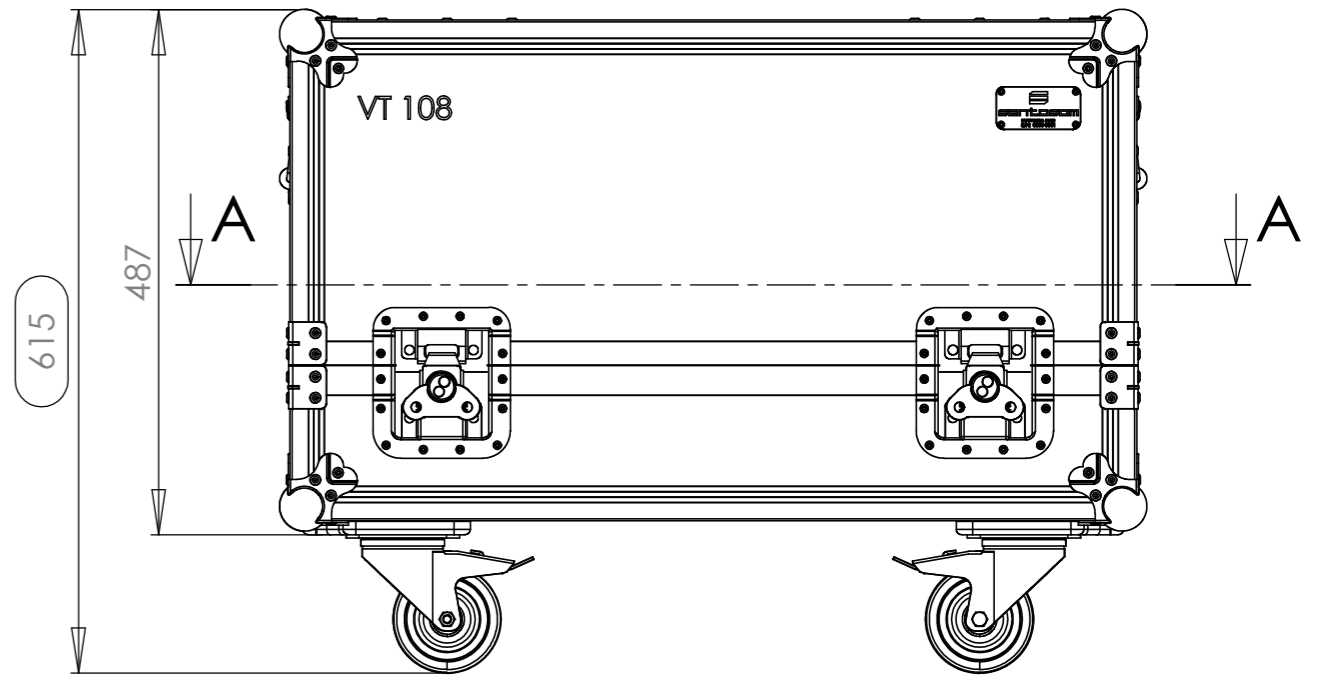
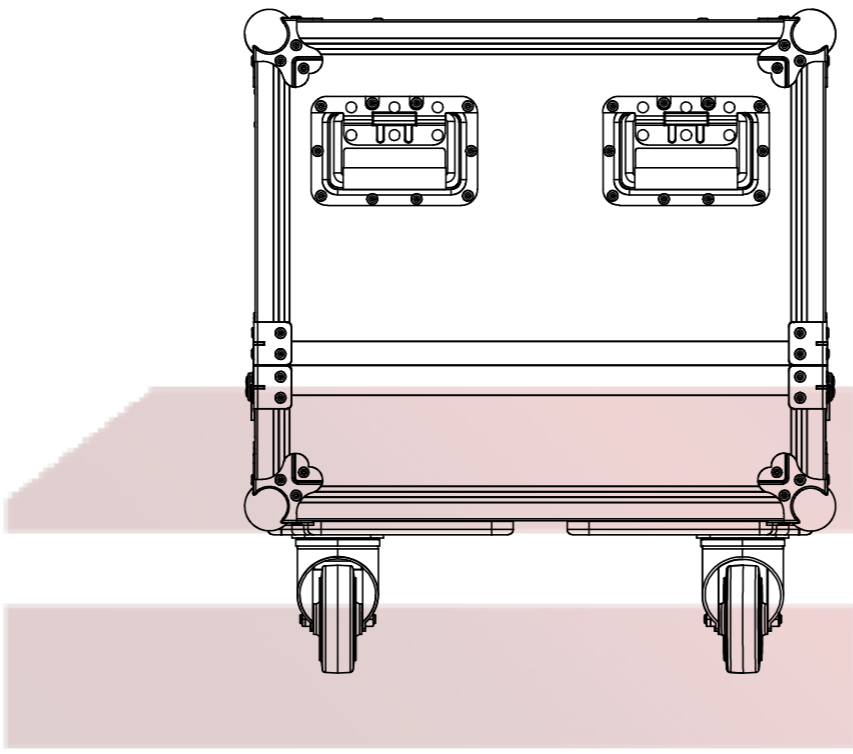
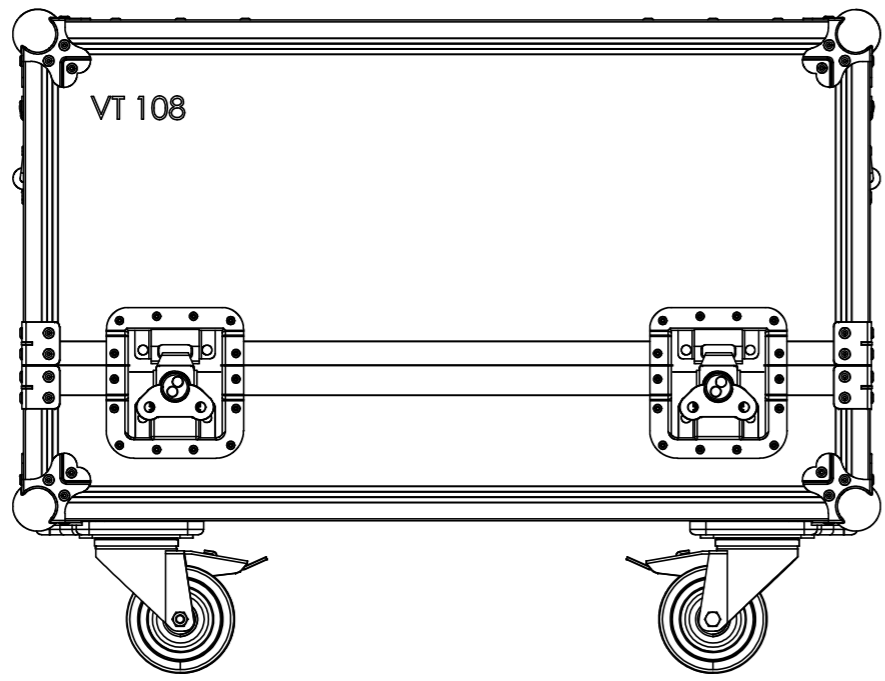
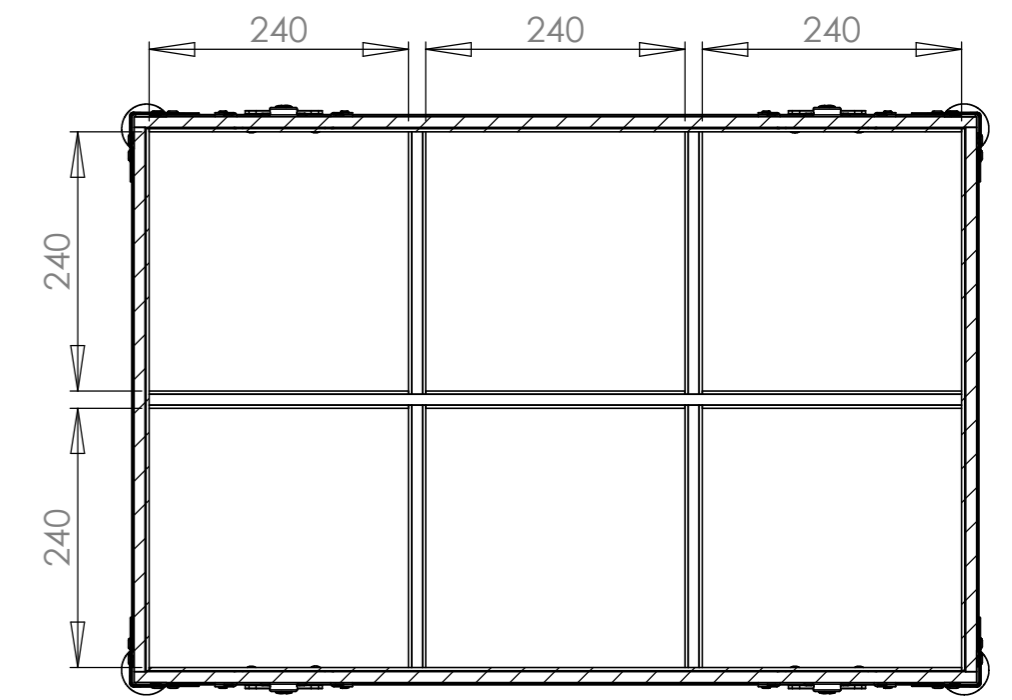
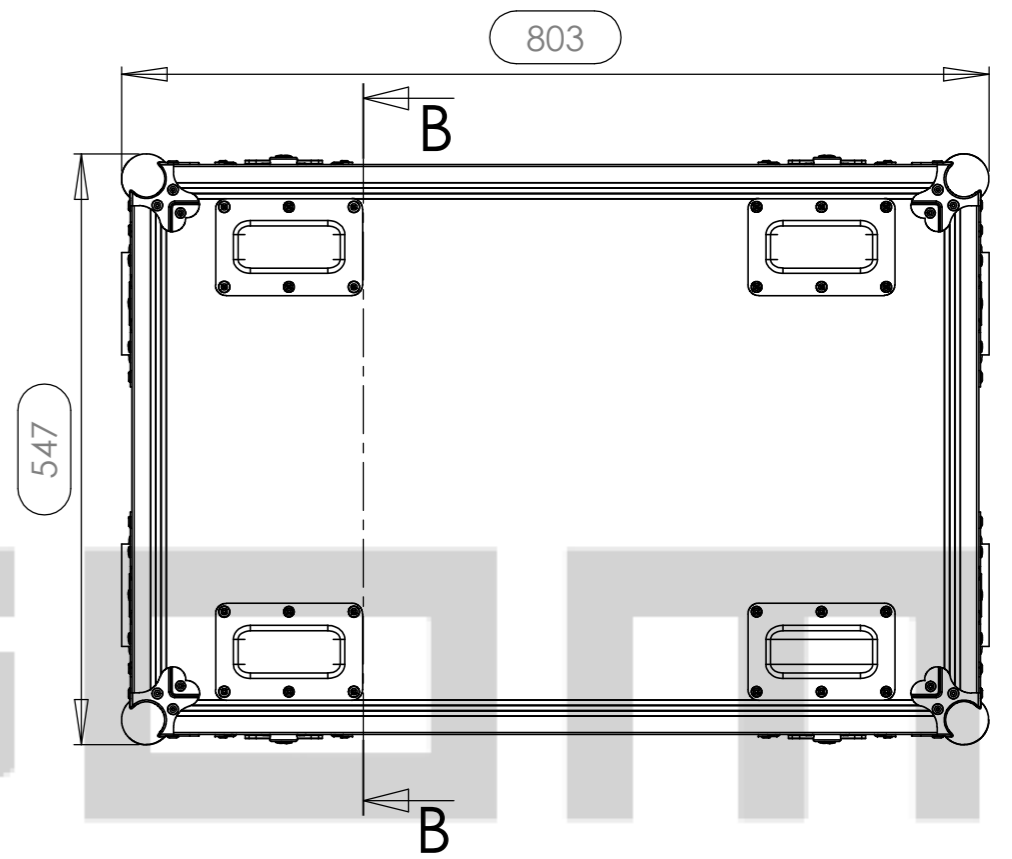

SECTION A-A

Hardware	
Qty	Description
8	Large corner bracket f. 35mm case angle
8	Ball Corner large three-leg cranked 35 mm 9 holes
4	Castor dish deep zinc plated
2	Swivel castor Ø100 mm with brake
2	Swivel castor Ø100 mm
4	Recessed sprung handle medium model
4	Large butterfly V3 with 'push-back' function in 14mm dish

This drawing must not be copied or disclosed without consent of the owner 	Reference Scale 1:7 1st Angle projection	Name Daniel Lopes Date 29-01-2013 Reference CABINET.907 general tolerance 0.05mm FC. 6 HK VT108, rodas	 SANTOSOM PINTAS E LACAS
---	---	--	--------------------------------