

Equipment			YAMAHA DBR15		
Width	Depth	Height			
455	378	700			
Internal Dimensions					
Width	Depth	Height			
460	383	691			
Weight	Approx. 20 Kg				
Wall Thickness		9.5mm			

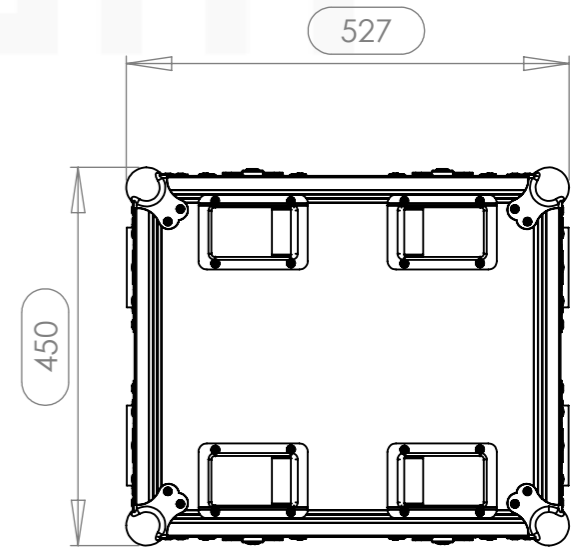
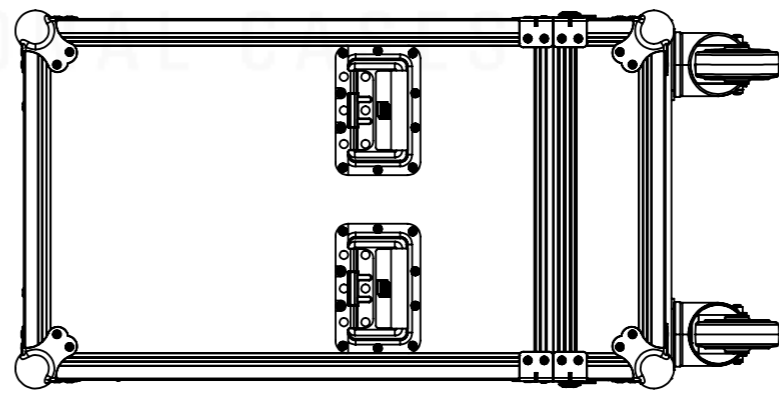
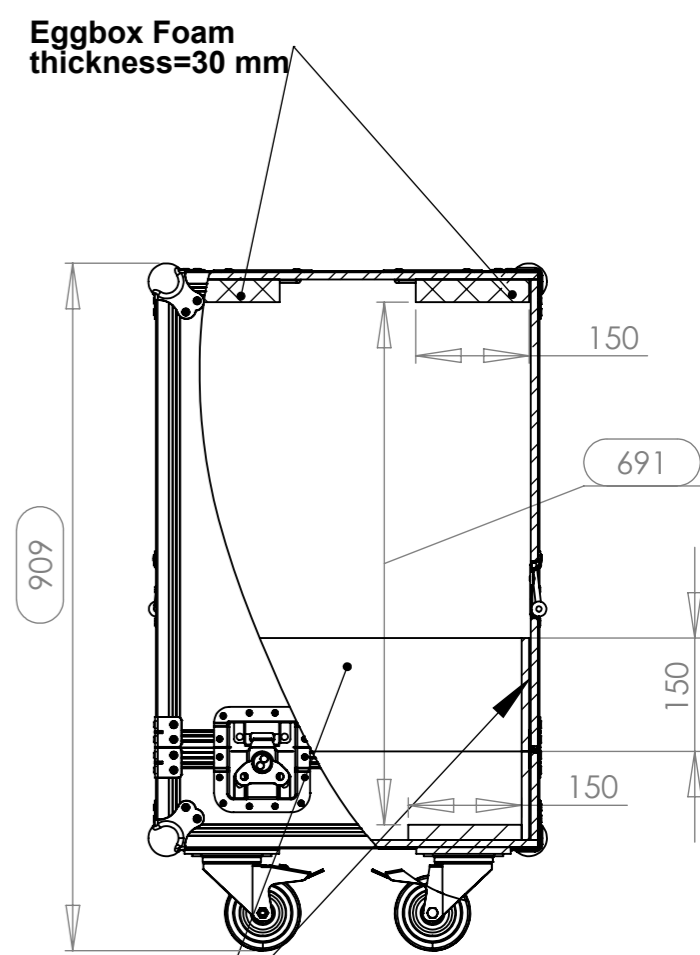
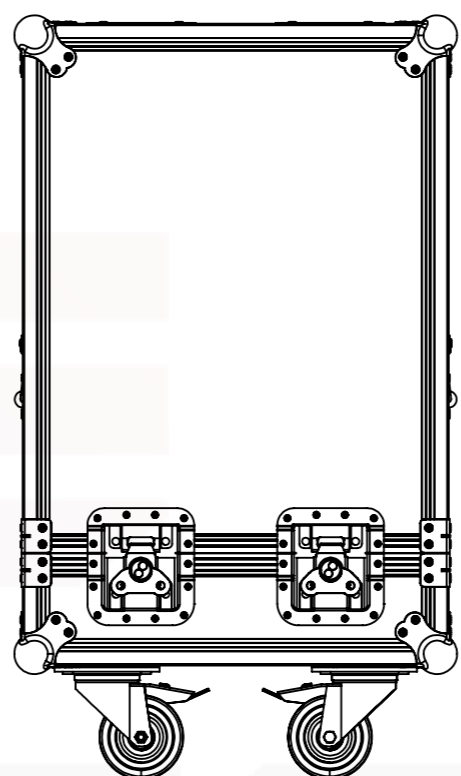
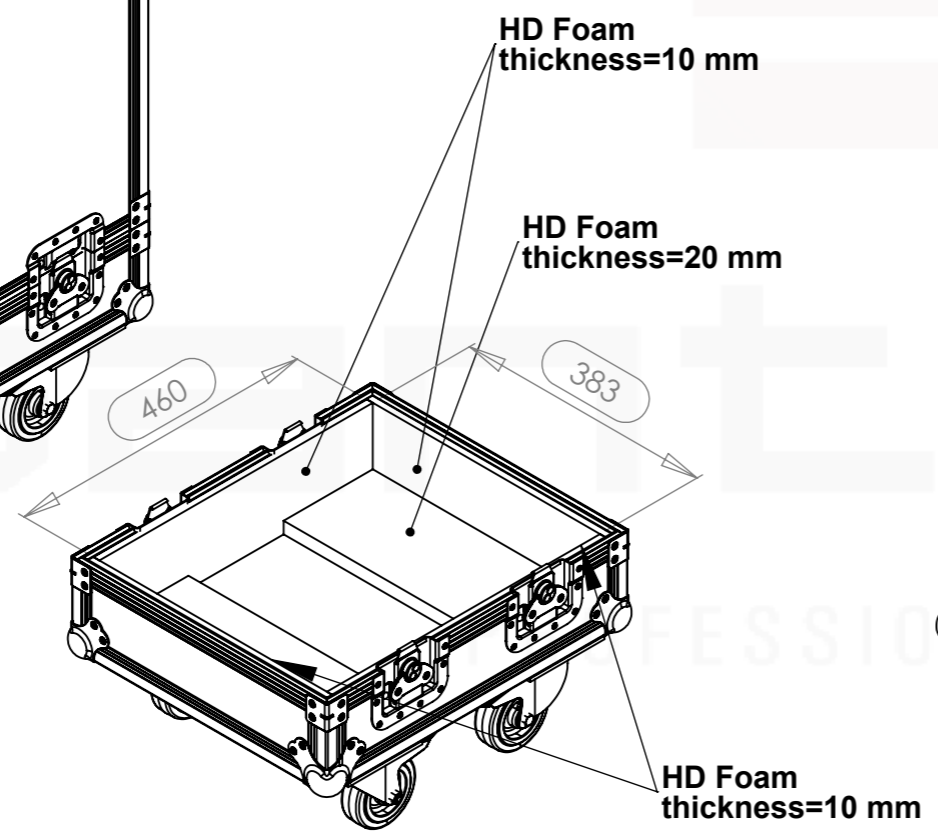
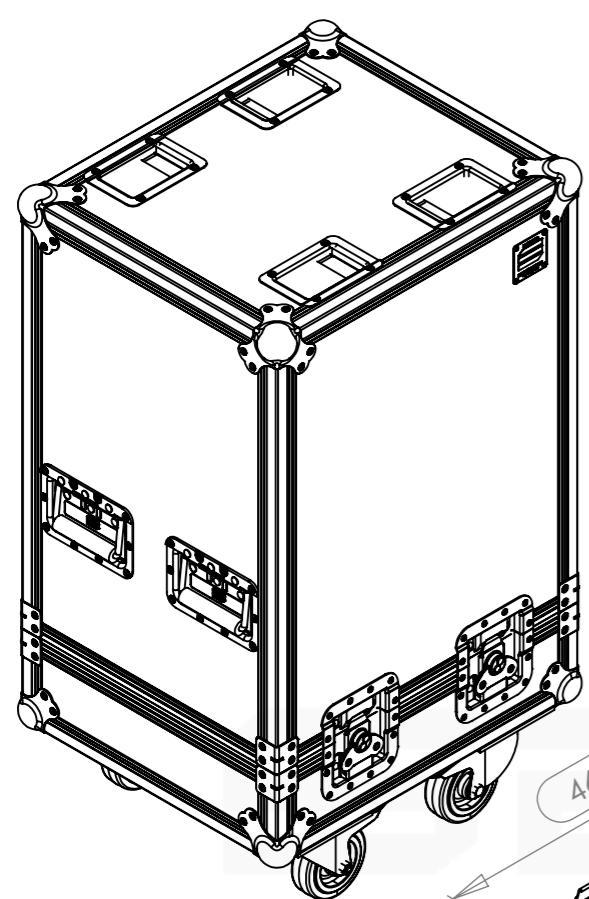

Hardware		
Qty	Ref.	Description
8	40403	Large corner bracket f. 35mm case angle
4	34082	Recessed sprung handle medium model
2	RODA.100T	Swivel castor Ø100mm with brake
2	RODA.100	Swivel castor Ø100 mm
8	4101	Heavy duty ball corner, zinc plated
4	38082	Castor dish deep zinc plated
4	172531	Large butterfly V3 with 'push-back' function

This drawing must not be copied or disclosed without consent of the owner

Drawn by	alexandre	Date	14/10/2016
Reference	CABINET.565E		
Scale	1:9	units in mm	general tolerance 0.8mm
1st Angle projection	FC ECOLINE, YAMAHA DBR15, RODAS		

