

Interior dimensions		
Width	Depth	Height
350	410	680
Weight	Approx. 30 Kg	
Wall Thickness	10mm	

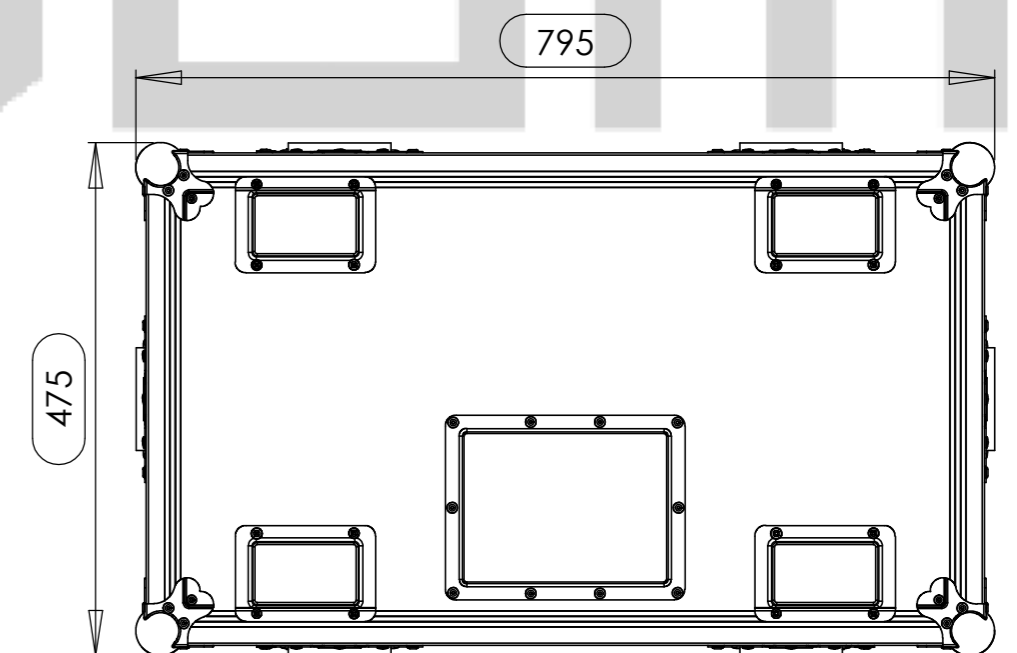
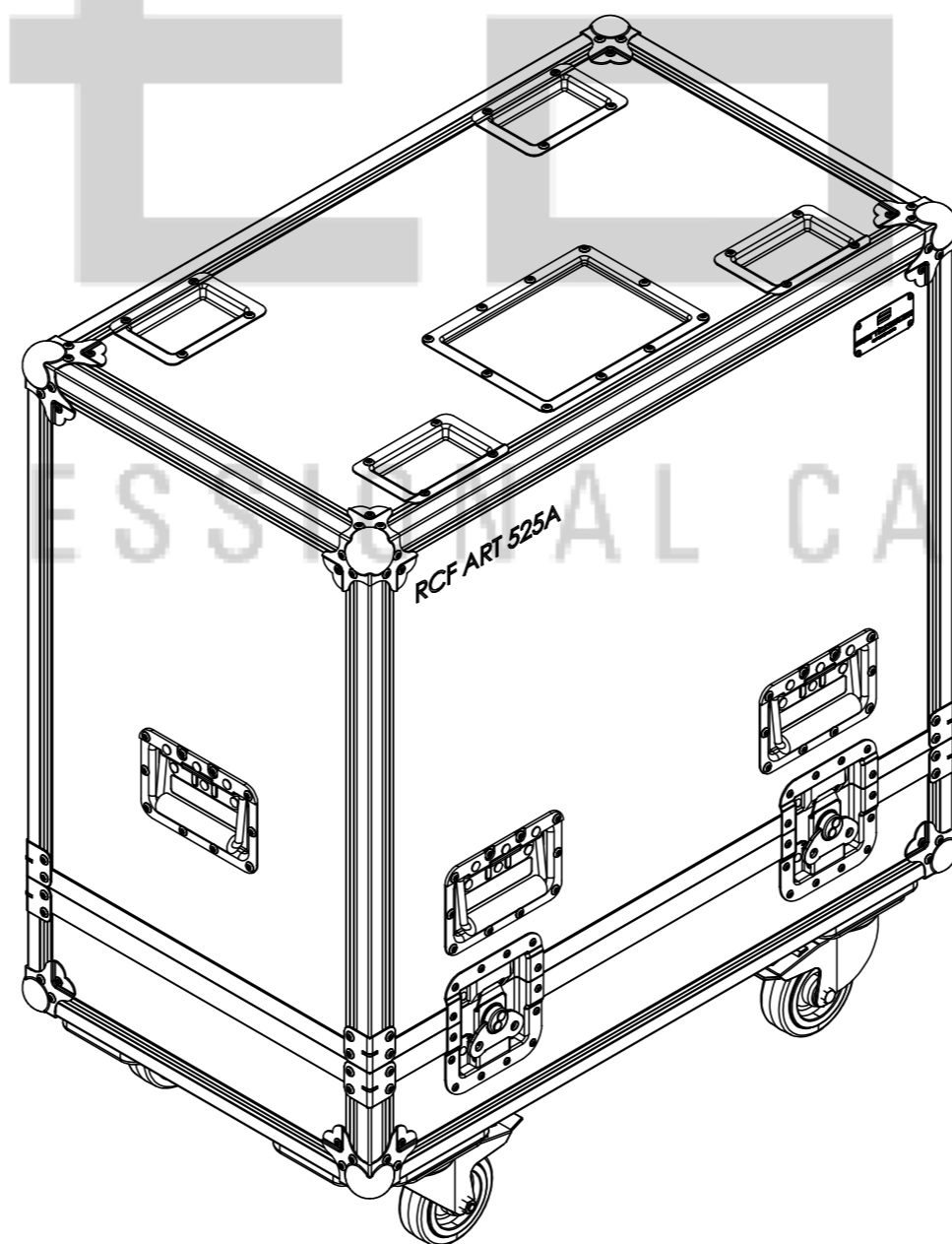
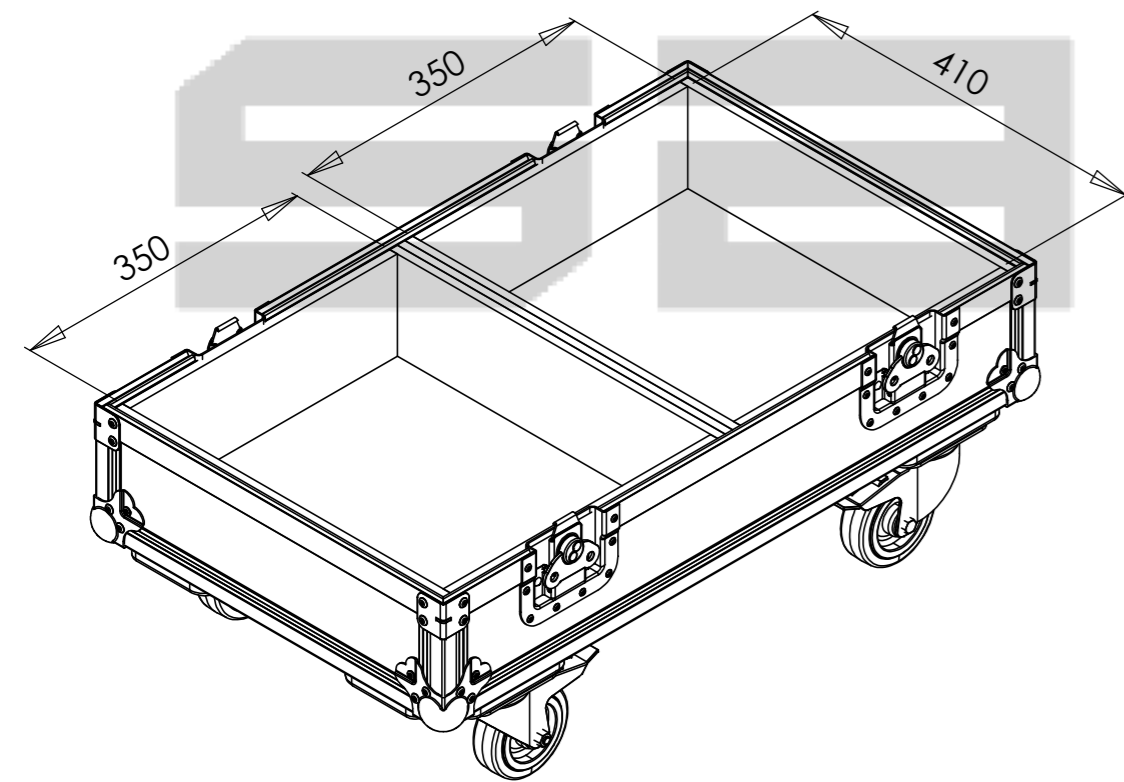
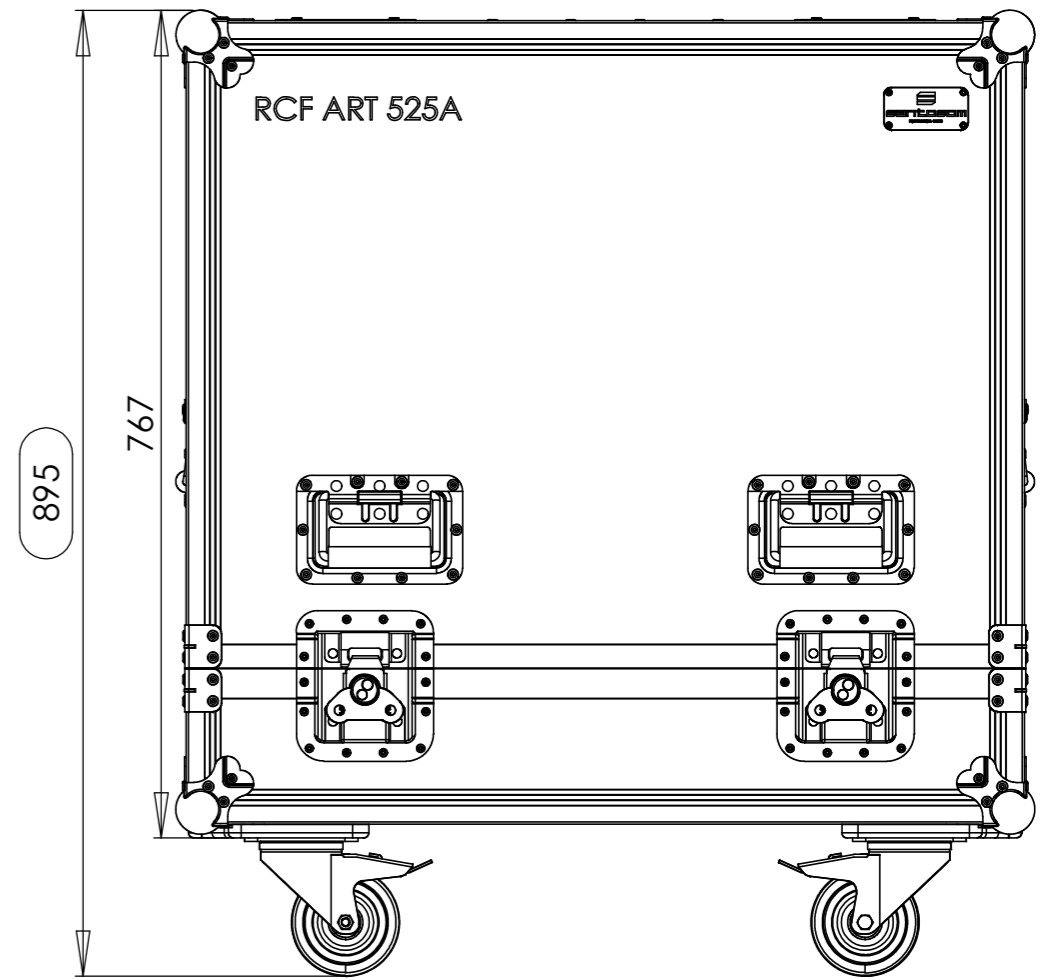
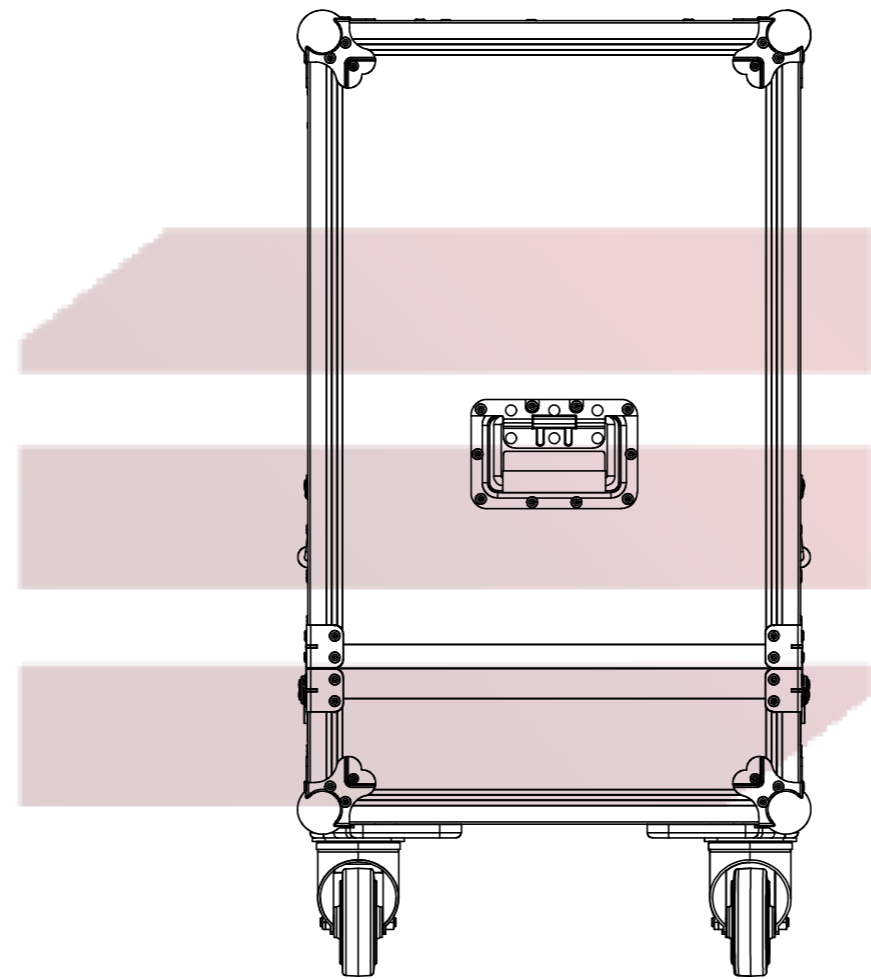
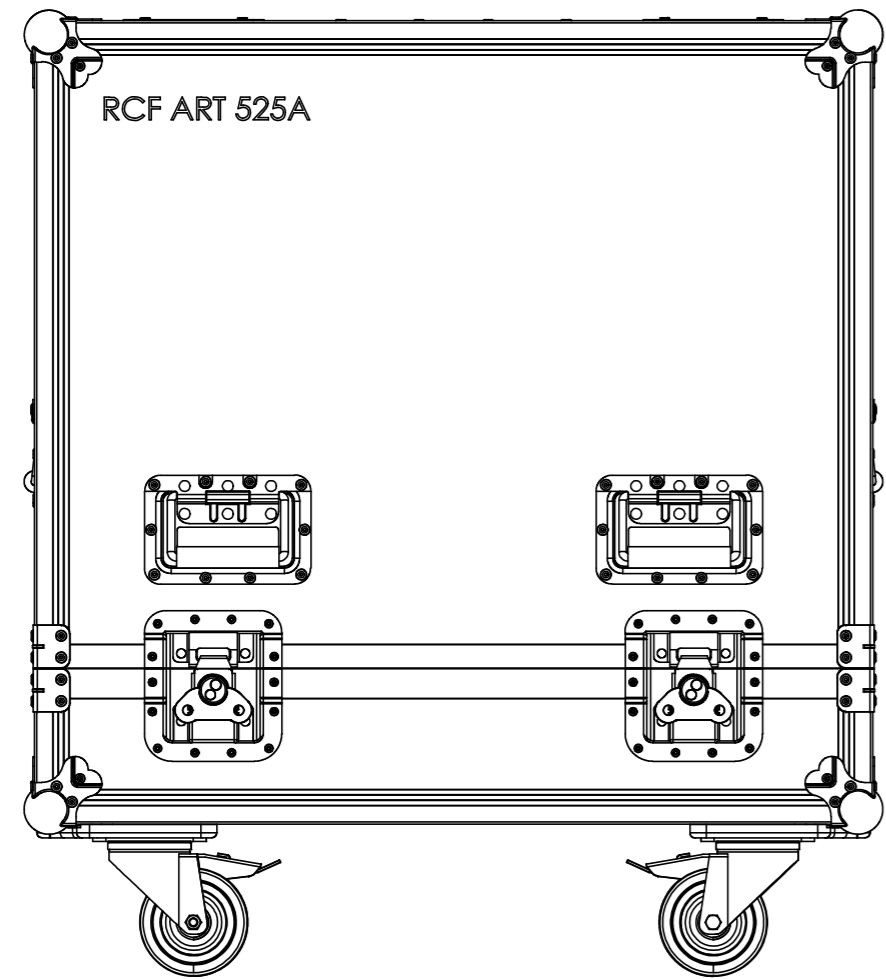

Hardware

Qty	Description
8	Large corner bracket f. 35mm case angle
8	Ball Corner large three-leg cranked 35 mm 9 holes
2	Swivel castor Ø100 mm with brake
2	Swivel castor Ø100 mm
4	Large butterfly V3 with 'push-back' function in 14mm dish
4	Castor dish deep zinc plated
1	Dish for 88001 Tour Label
6	Recessed sprung handle medium model

This drawing must not be copied or disclosed without consent of the owner

Drawn by	Name	Date
DanielLopes	DanielLopes	20-06-2012
Reference	CABINET.409R1	
Scale	1:7	
1st Angle projection	FC. 2 RCF ART 525A	

