

Interior dimensions		
Width	Depth	Height
435	385	240
Weight	Approx. 18 Kg	
Wall Thickness	7mm	

Medidas maximas do Equipamento		
Largura(w)	Profundidade(D)	Altura(H)
430	380	250

REVISIONS				
ZONE	REV.	DESCRIPTION	DATE	APPROVED
	0	Final Drawing	11/05/2015	Carlos Rodrigues

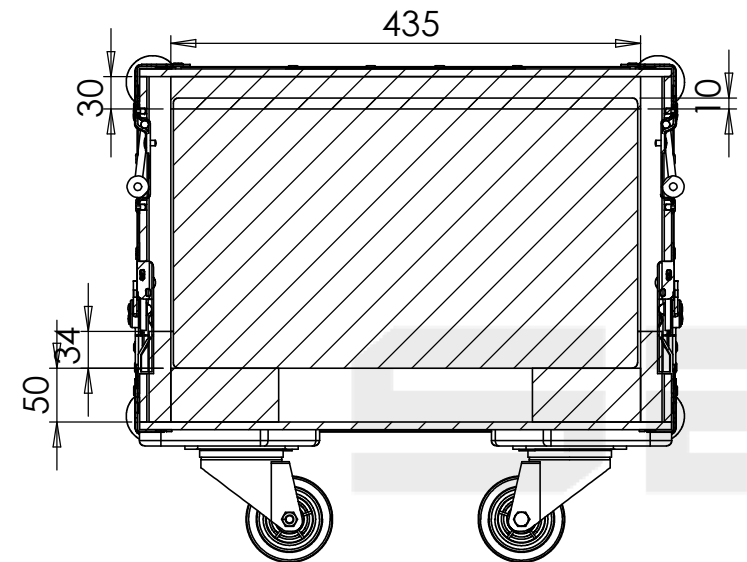
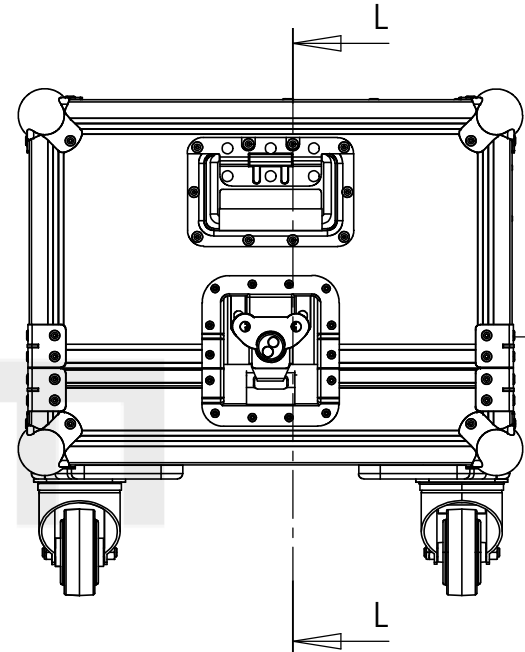
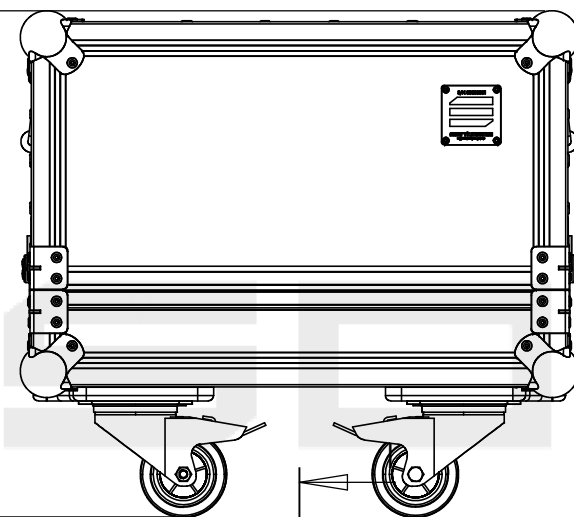
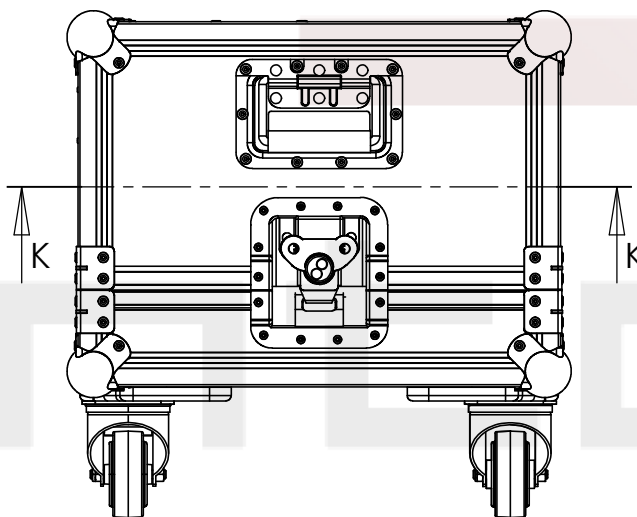
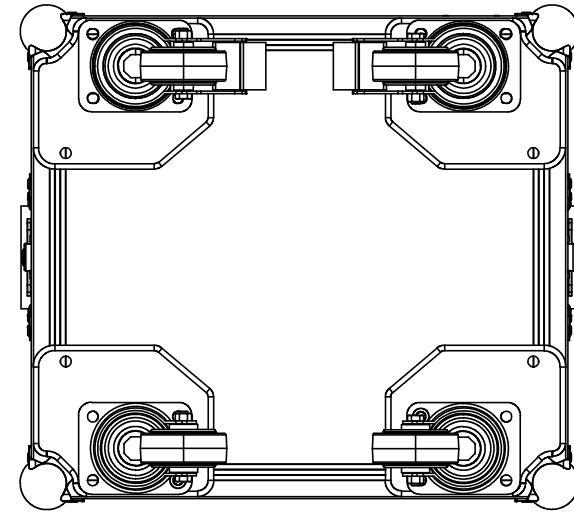
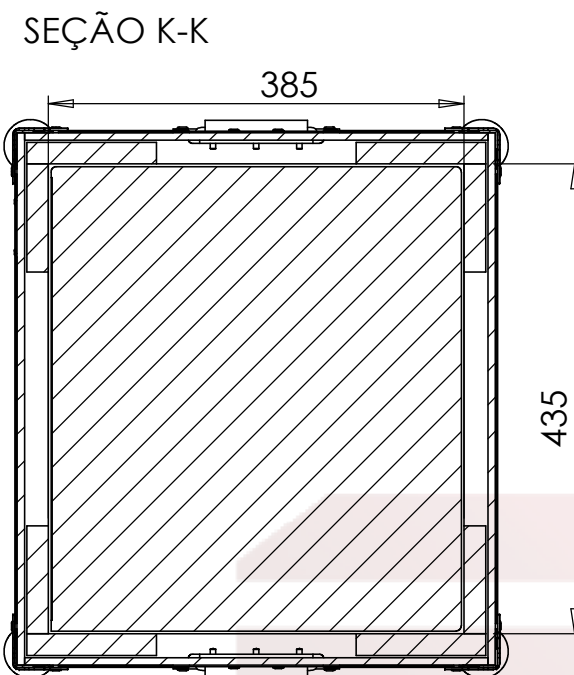

SEÇÃO L-L

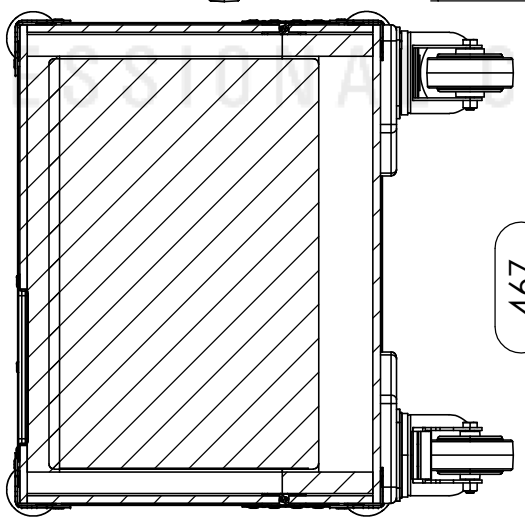

SEÇÃO H-H

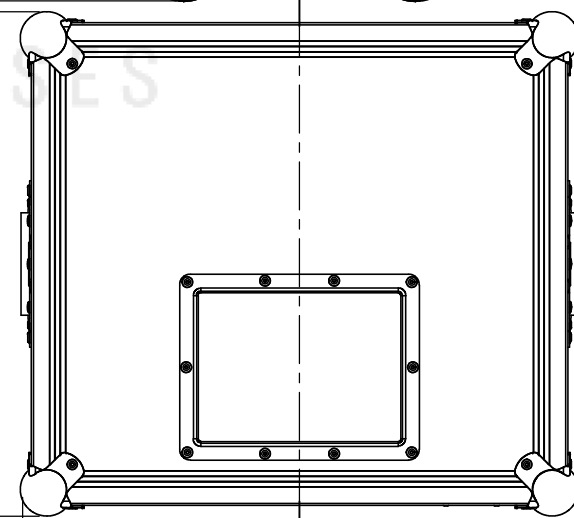

515

Hardware		
Qty	Ref.	Description
2	RODA.80	Swivel castor Ø80 mm without brake
2	172531	Large butterfly V3 with 'push-back' function
8	4120	Medium ball corner zinc plated
8	40403	Large corner bracket f. 35mm case angle
2	RODA.80T	Swivel castor Ø80 mm with brake
1	88001D	Dish for 88001 Tour Label
1	CHAPA.1000	Identification Plate
2	34082	Recessed sprung handle medium model

A3 This drawing must not be copied or disclosed without consent of the owner

1st Angle projection

Scale 1:7  
units in mm  
DO NOT SCALE  
general tolerance 0.8mm

Name Date  
Drawn by projects 11/05/2015  
Reference CABINET.374

