

Exterior dimensions		
Width	Depth	Height
829	603	837
Weight	Approx. 37 Kg	
Wall Thickness	10mm	

REVISIONS				
ZONE	REV.	DESCRIPTION	DATE	APPROVED
-	-	Final Drawing	19/03/2014	Telmo Santos

### SECTION A-A

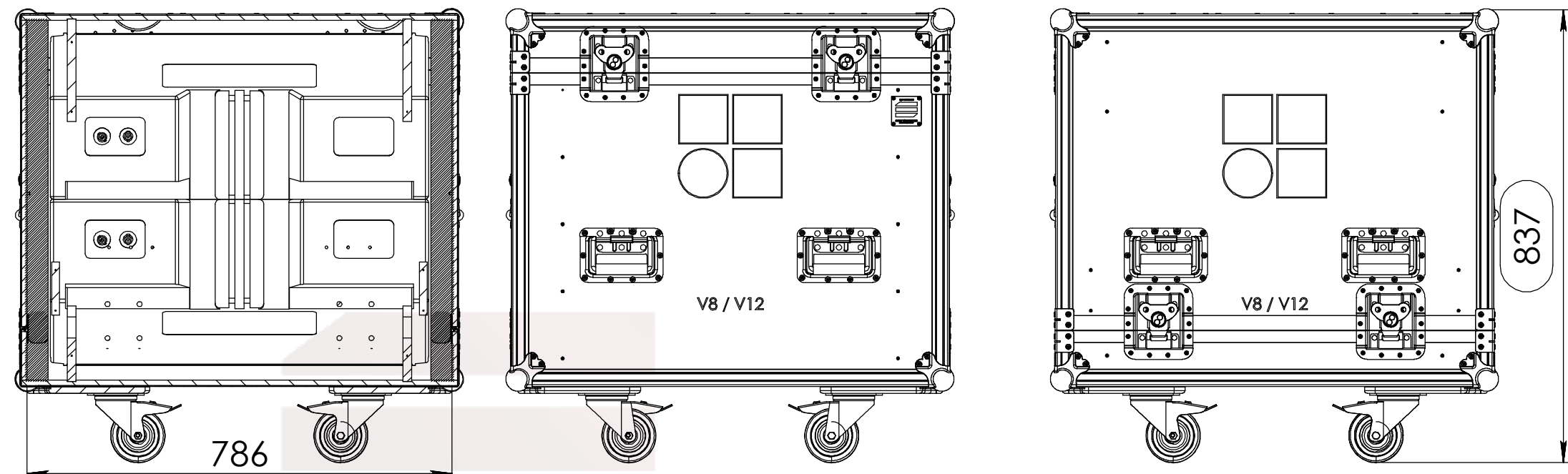

### SECTION B-B 711,5

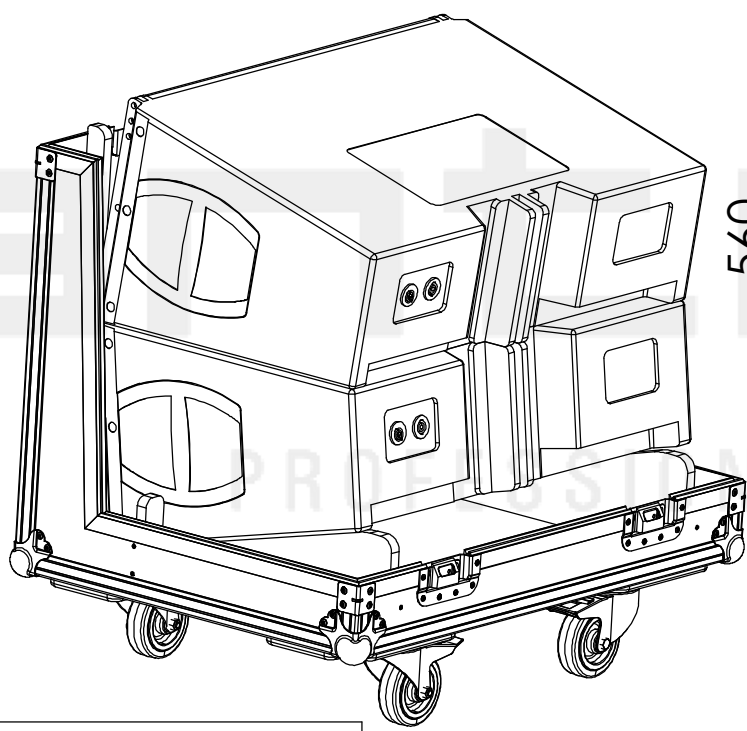
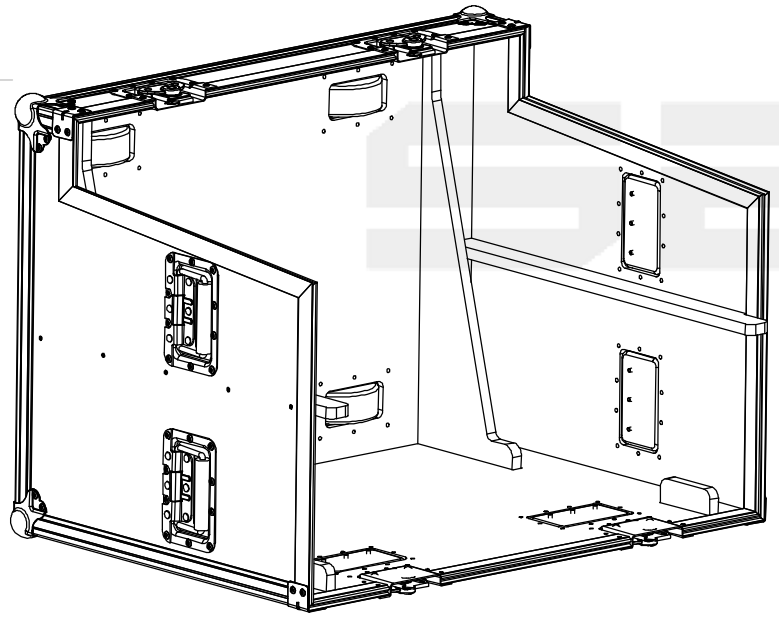
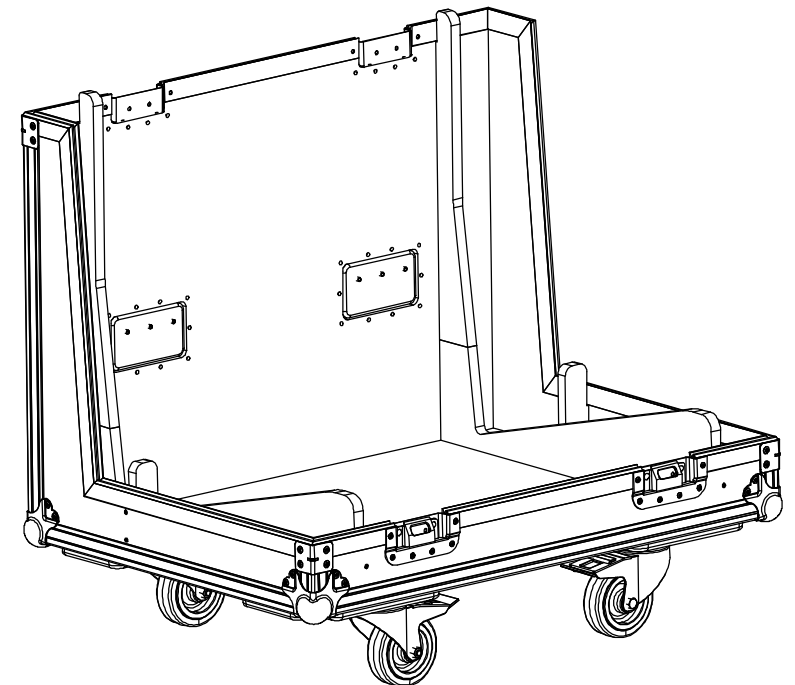
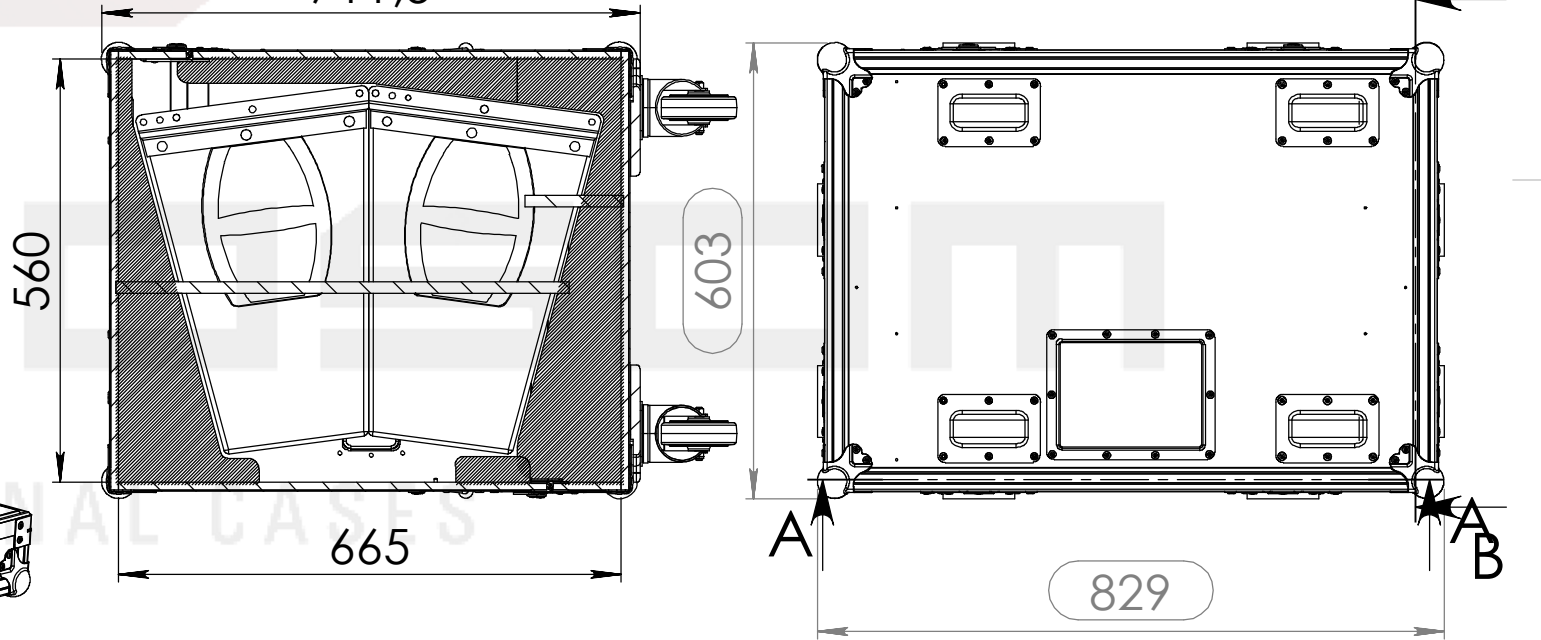

Hardware		
Qty	Ref.	Description
8	410429	Heavy Duty Ball Corner
8	40403	Large corner bracket f. 35mm case angle
2	RODA.100T	Swivel castor Ø100mm with brake
8	34082	Recessed sprung handle medium model
4	172531	Large butterfly V3 with 'push-back' function
2	RODA.100	Swivel castor Ø100 mm
4	38083	Castor dish deep zinc plated
1	88001D	Dish for 88001 Tour Label

This drawing must not be copied or disclosed without consent of the owner

Drawn by	Name	Date
Telmo Santos	Telmo Santos	19/03/2015
Reference	CABINET.362R	
Scale	units in mm	general tolerance
1:10	DO NOT SCALE	0.8mm
1st Angle projection	FC. 4X DB TECHNOLOGIES DVA 112, RODAS	

