

Interior dimensions

Width	Depth	Height
755	665	745
Weight	Approx. 38 Kg	
Wall Thickness		10mm

REVISIONS

ZONE	REV.	DESCRIPTION	DATE	APPROVED
-	-	Final Drawing	18/08/2014	Delfim Alves

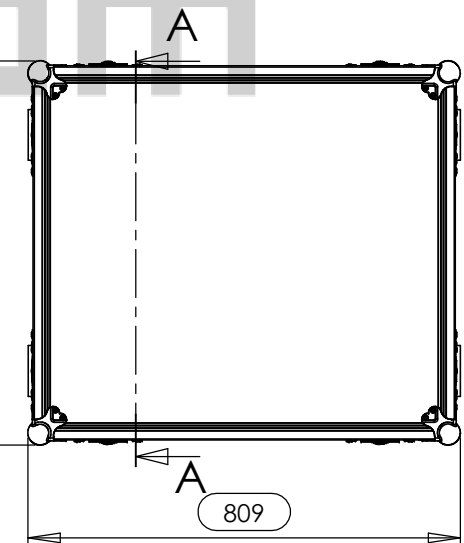
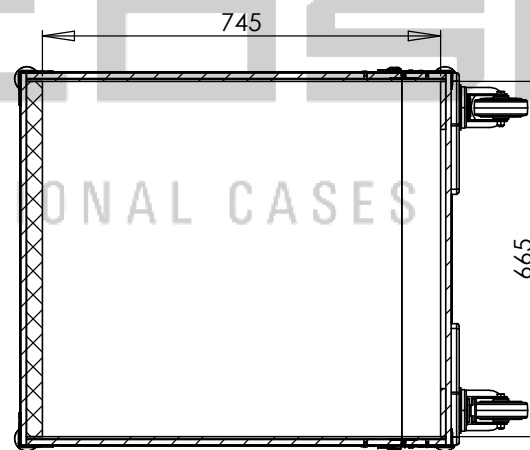
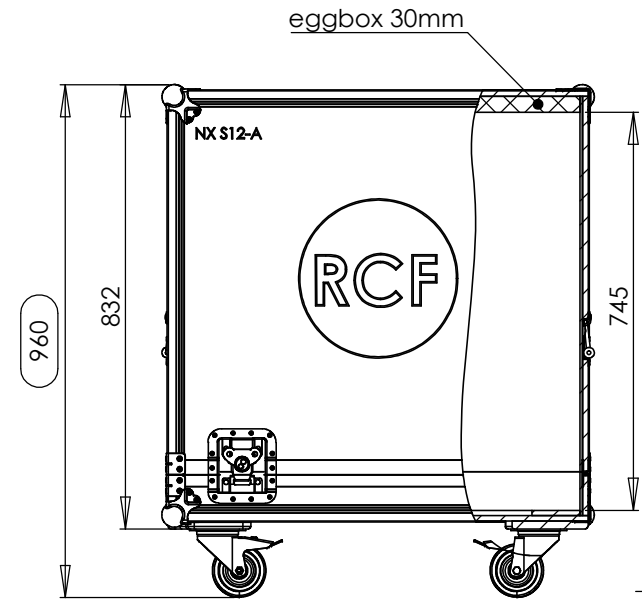
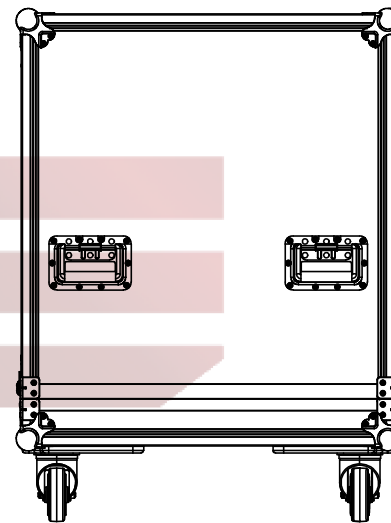
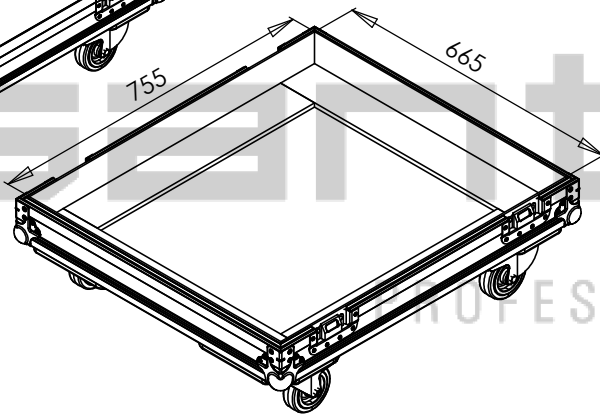
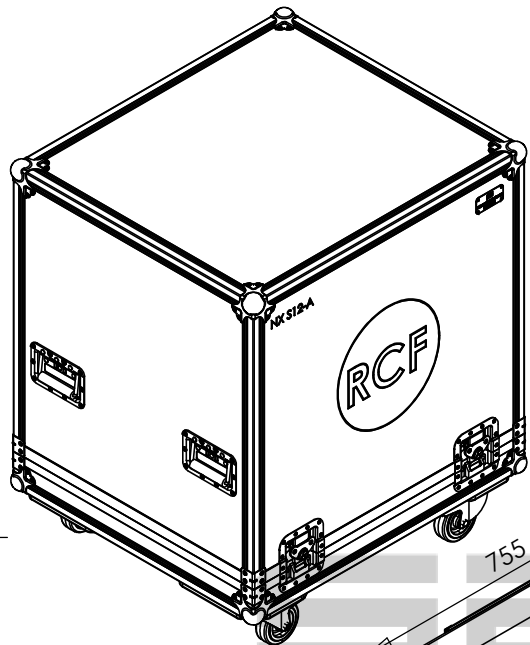

SECTION A-A

Hardware

Qty	Ref.	Description
8	410429	Heavy Duty Ball Corner
8	40403	Large corner bracket f. 35mm case angle
2	RODA.100T	Swivel castor Ø100mm with brake
2	RODA.100	Swivel castor Ø100 mm
4	172531	Large butterfly V3 with 'push-back' function
4	34082	Recessed sprung handle medium model

This drawing must not be copied or disclosed without consent of the owner

Scale	1:10	general tolerance	0.8mm
Reference	CABINET.253R		
FC, TURBOSOUND MILAN	SUB M188, RODAS		

