

Interior dimensions		
Width	Depth	Height
644	535	585
Weight	Approx. 29 Kg	
Wall Thickness	10mm	

REVISIONS				
ZONE	REV.	DESCRIPTION	DATE	APPROVED
-	-	Final Drawing	18/08/2014	Daniel Lopes

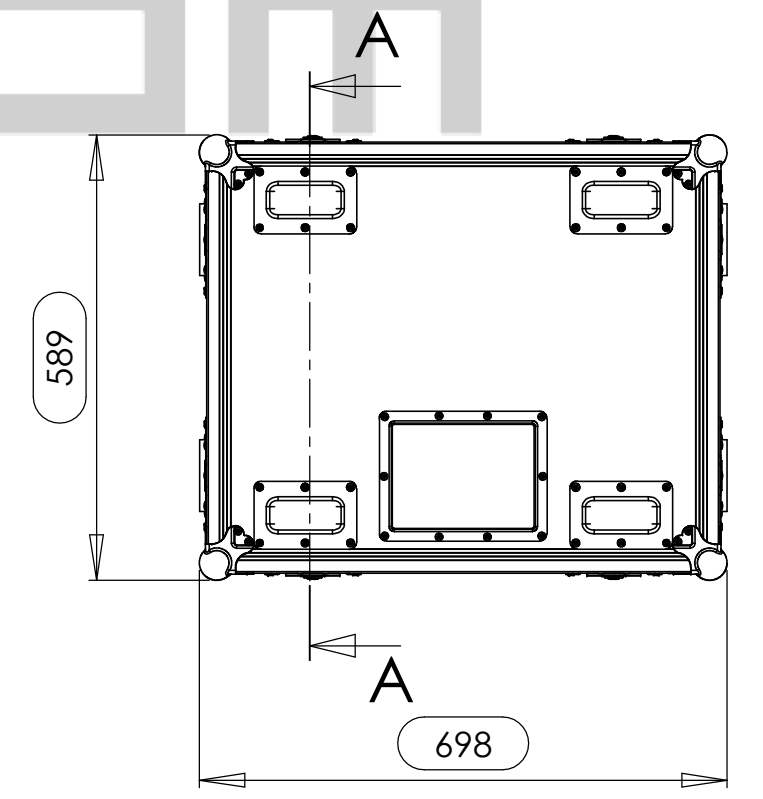
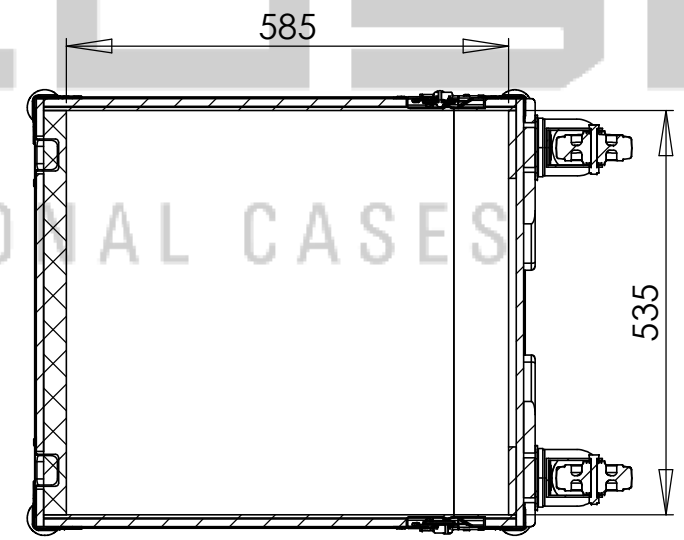
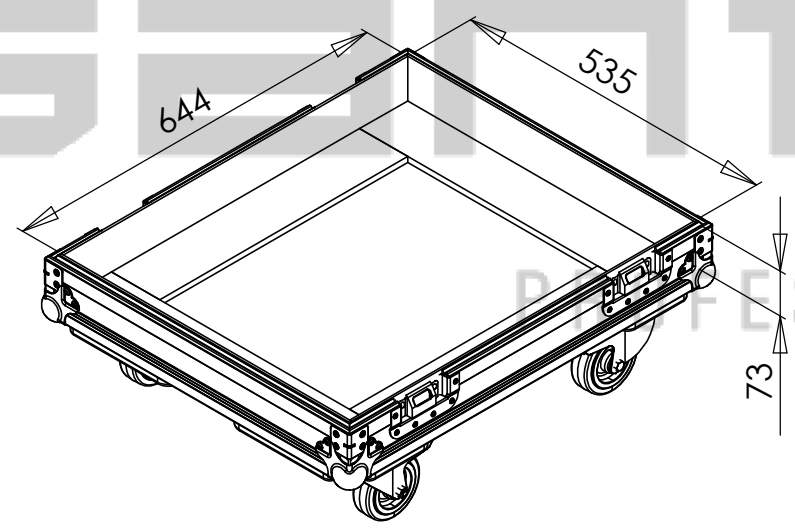
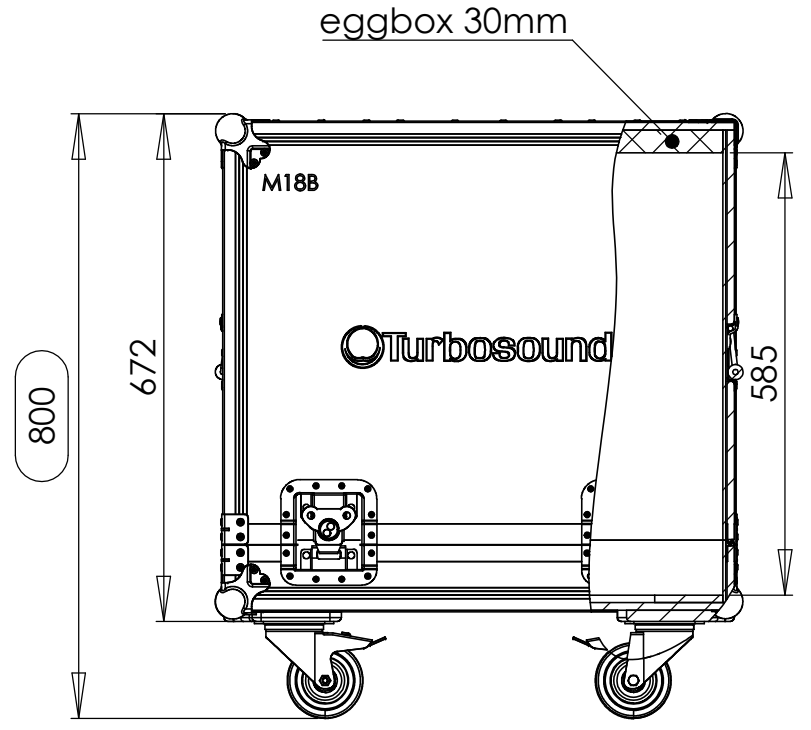
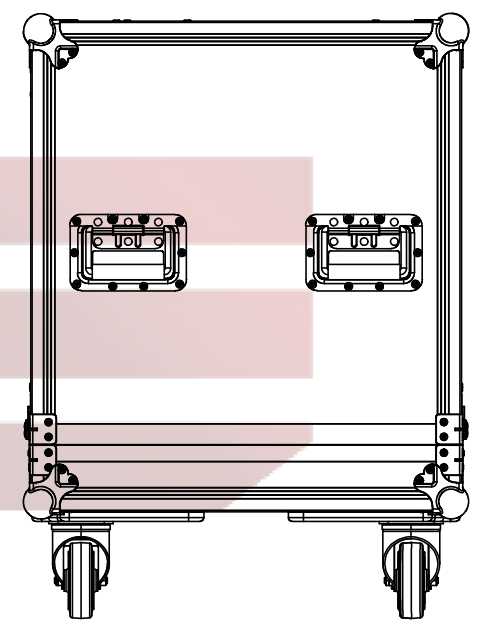
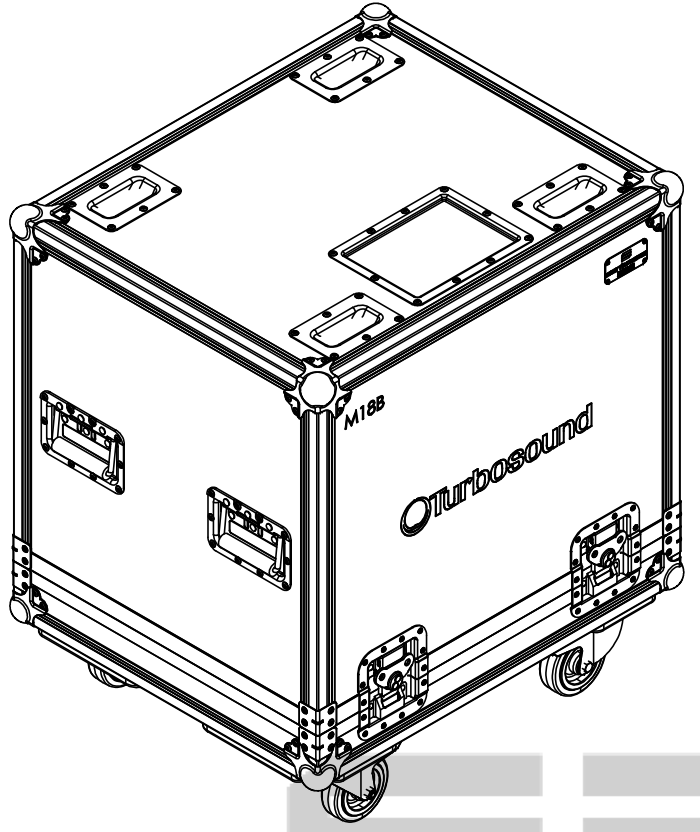

Hardware		
Qty	Ref.	Description
8	410429	Heavy Duty Ball Corner
8	40403	Large corner bracket f. 35mm case angle
1	88001D	Dish for 88001 Tour Label
2	RODA.100T	Swivel castor Ø100mm with brake
2	RODA.100	Swivel castor Ø100 mm
4	172531	Large butterfly V3 with 'push-back' function
4	34082	Recessed sprung handle medium model
4	38083	Castor dish deep zinc plated

SECTION A-A

This drawing must not be copied or disclosed without consent of the owner

Name	Date
Drawn by: DanielLopes	19-08-2014
Reference	CABINET.253R
Scale	1:10
units in mm	general tolerance 0.8mm
DO NOT SCALE	
FC, TURBOSOUND MILAN SUB M18B, RODAS	

