

Equipment			Martin Audio XD12		
Width	Depth	Height			
360	341	571			
Internal Dimensions					
Width	Depth	Height			
343	361	560 (Pressing)			
Weight	Approx. 30 Kg				
Wall Thickness	10mm				

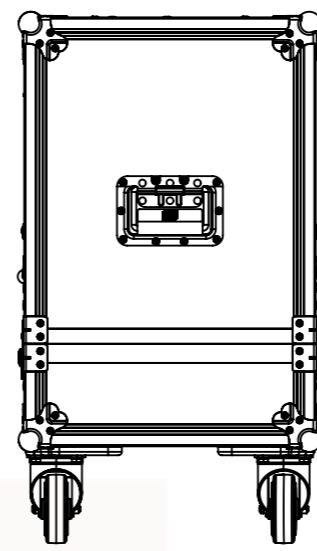

Martin Audio XD12
Weight: 19,5 Kg

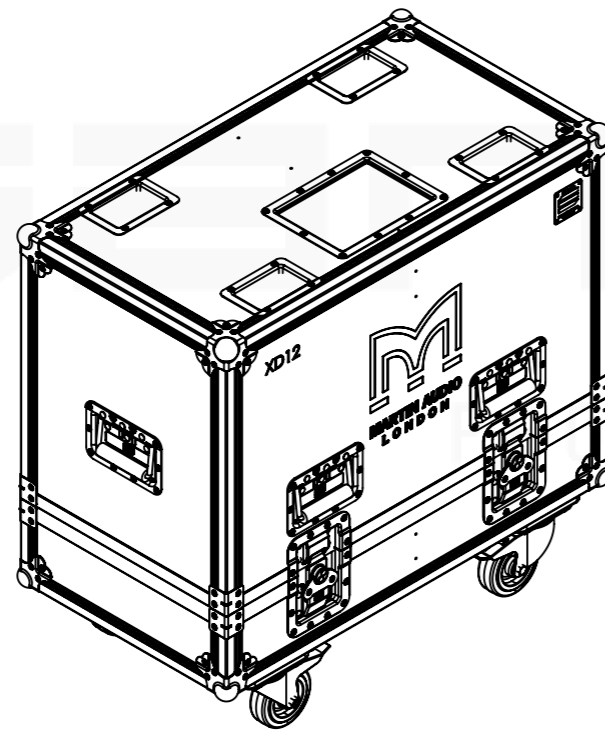
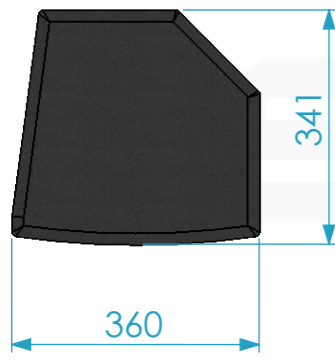

Pressing Eggbox
Foam 30 mm thick

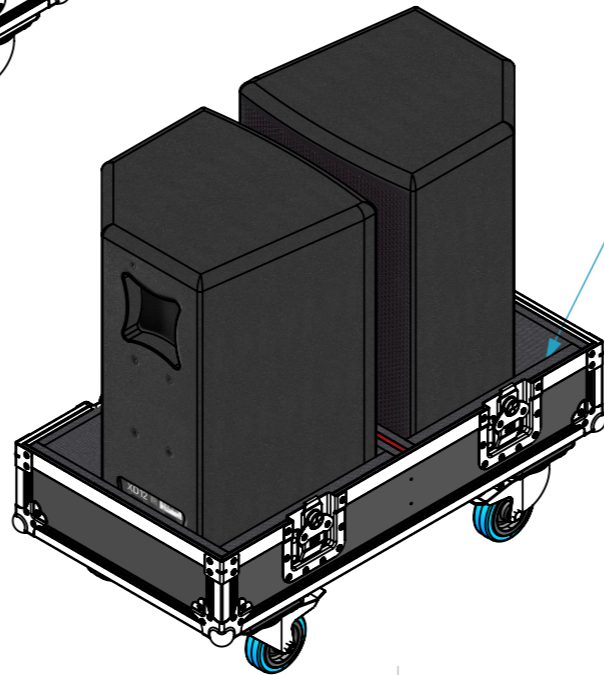
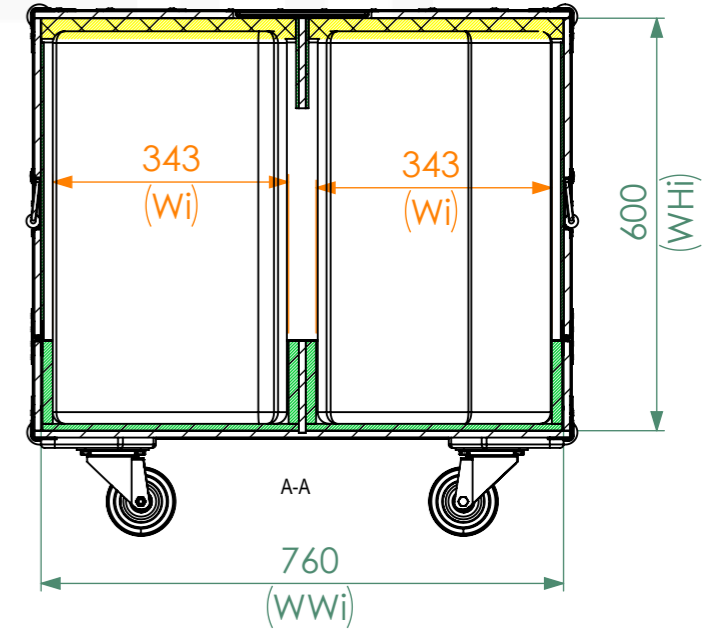
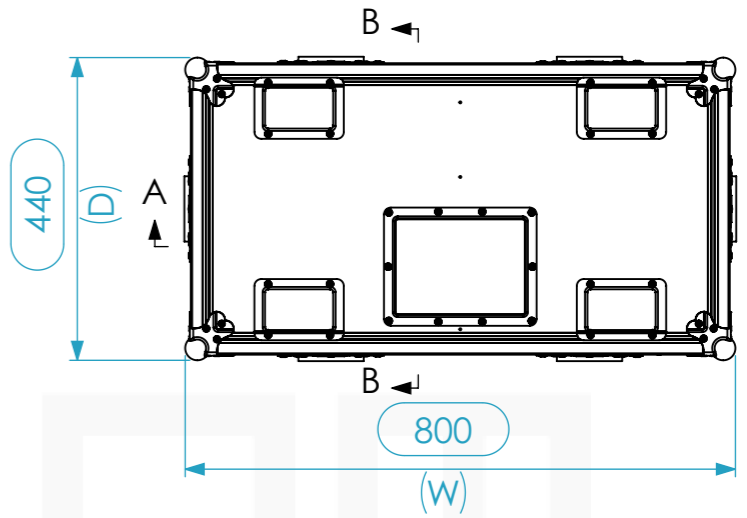
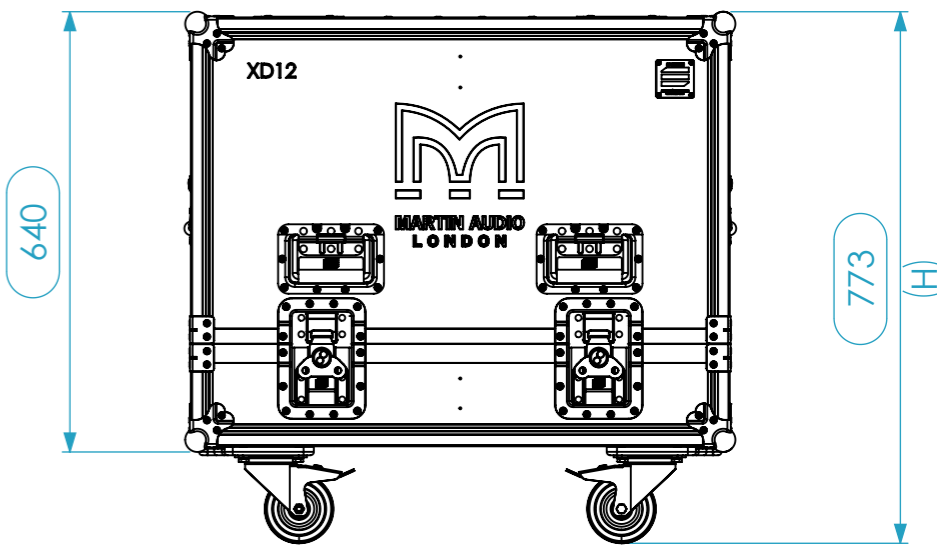
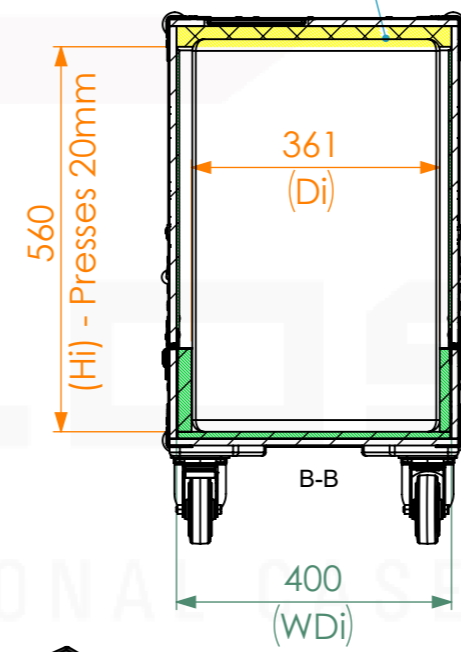

HD Foam

General External Dimensions		Usable Inner Dimensions (UID)		Wood Inner Dimensions (WID)	
W	Width	Wi	Inside Width	WWi	Wood Inside Width
D	Depth	Di	Inside Depth	WDi	Wood Inside Depth
H	Height	Hi	Inside Height	WHi	Wood Inside Height

This drawing must not be copied or disclosed without consent of the owner

Drawn by	alexandre	Date	30-09-2019
Reference	CABINET.056		
Scale	1:11	units in mm	general tolerance 0.8mm
1st Angle projection	Flight Case PRO, 2x Martin Audio XD12		

