

Equipment			DB TECHNOLOGIES LVX8		
Width	Depth	Height			
260	260	433			
Internal Dimensions					
Width	Depth	Height			
563	303	483			
Weight	Approx. 7 Kg				
Wall Thickness	7mm				

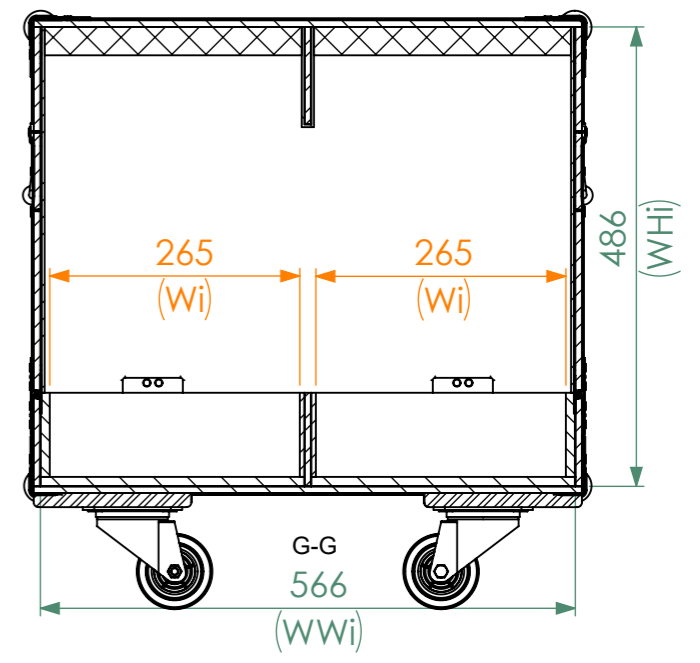

General External Dimensions		Usable Inner Dimensions		Wood Inner Dimensions	
W	Width	Wi	Inside Width	WWi	Wood Inside Width
D	Depth	Di	Inside Depth	WDi	Wood Inside Depth
H	Height	Hi	Inside Height	WHi	Wood Inside Height

Name	Date
Drawn by	CatarinaHenriques 23/04/2019
Reference	CABINET.042
Scale	1:8
units in mm	general tolerance 0.8mm
DO NOT SCALE	
1st Angle projection	FLIGHT CASE, 2X DB TECHNOLOGIES LVX8

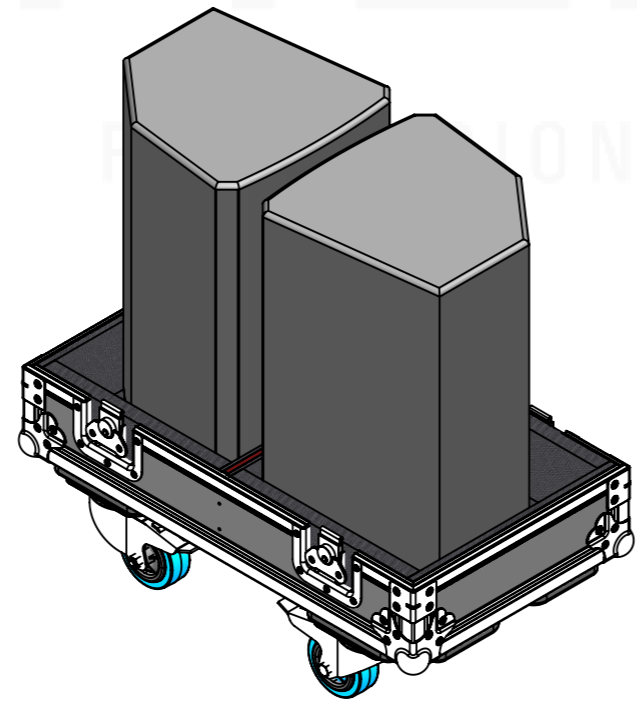
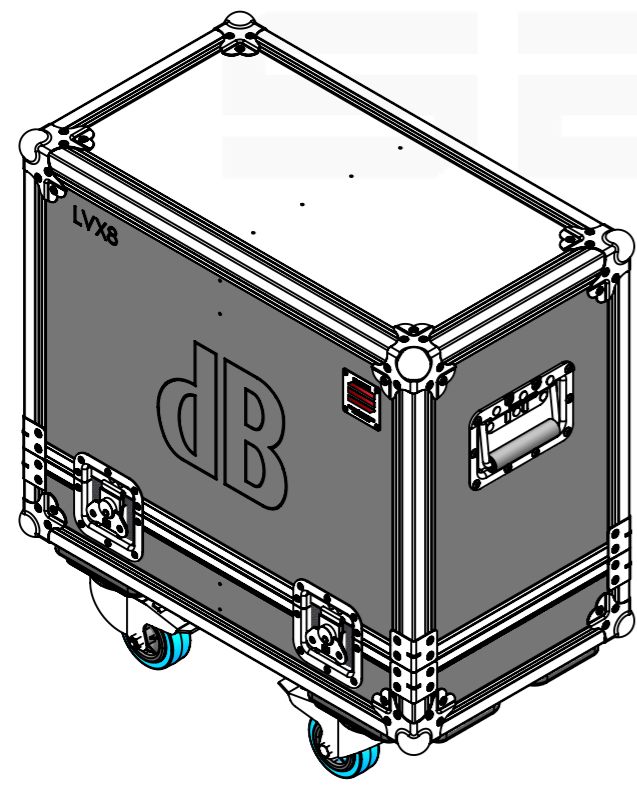
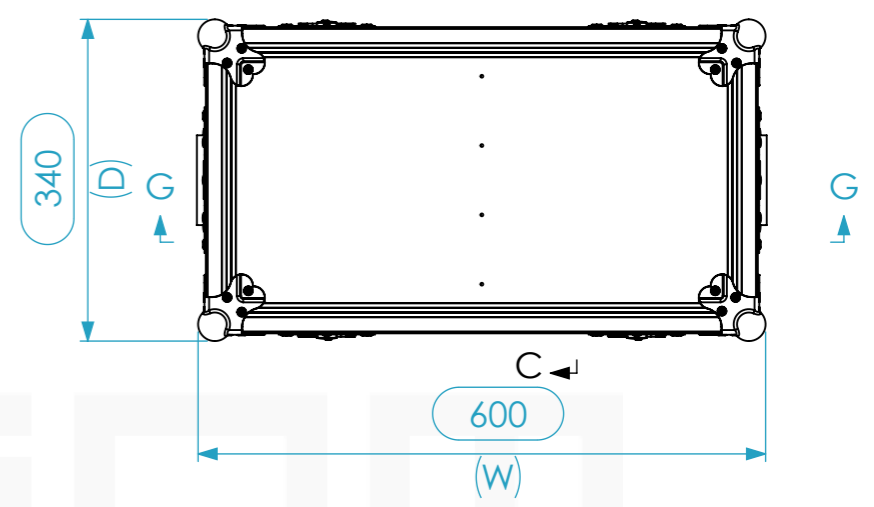
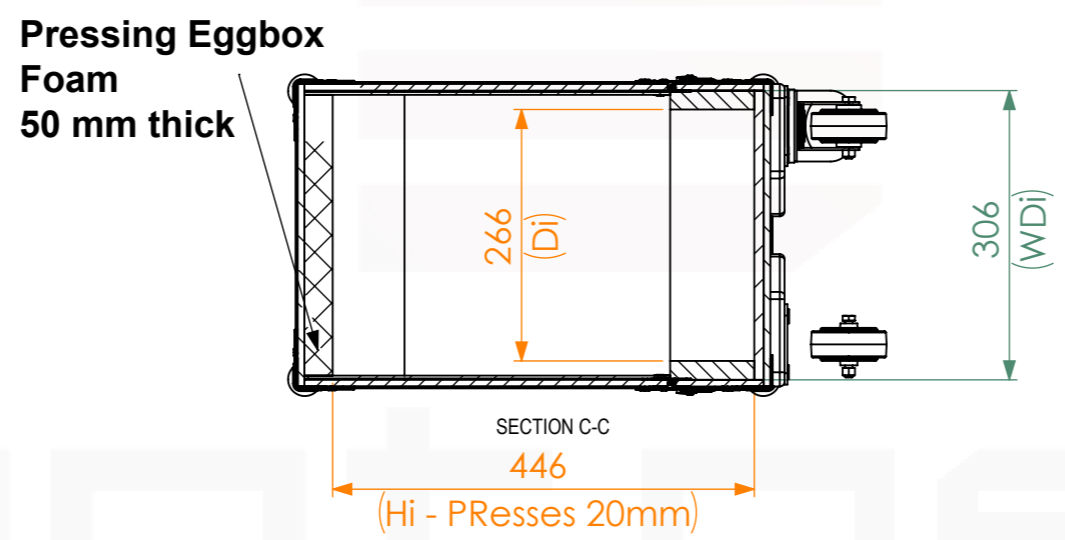
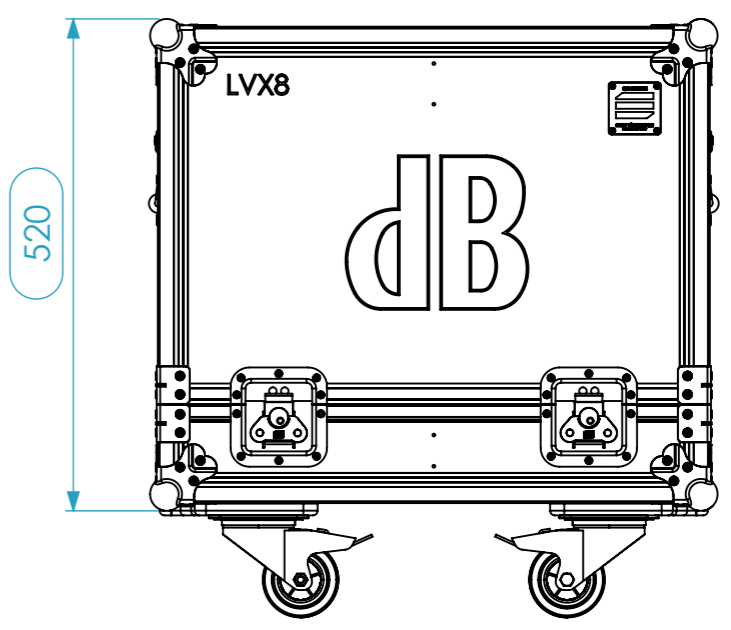
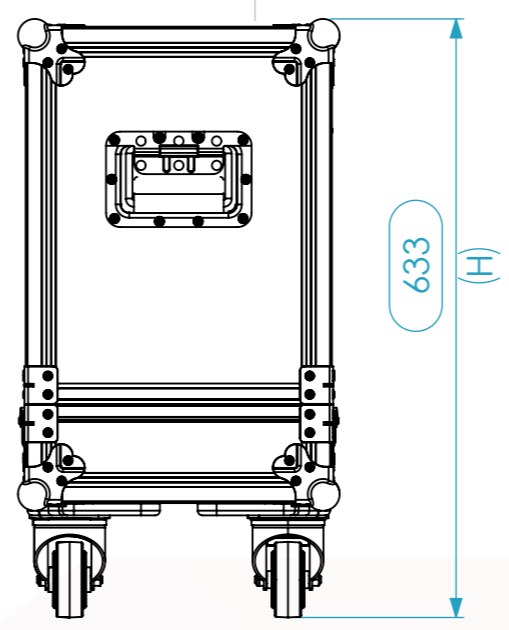
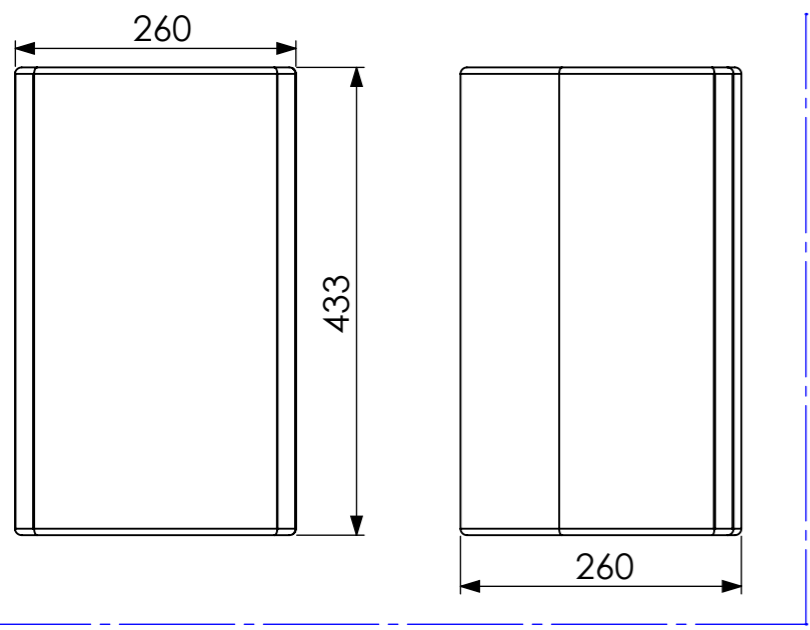

This drawing must not be copied or disclosed without consent of the owner

A3