

Equipment	ChainMaster D8+ Ultra 500 kg	
Width	Depth	Height
355	205	111
Weight	Approx. 11.86 Kg	
Wall Thickness		15mm

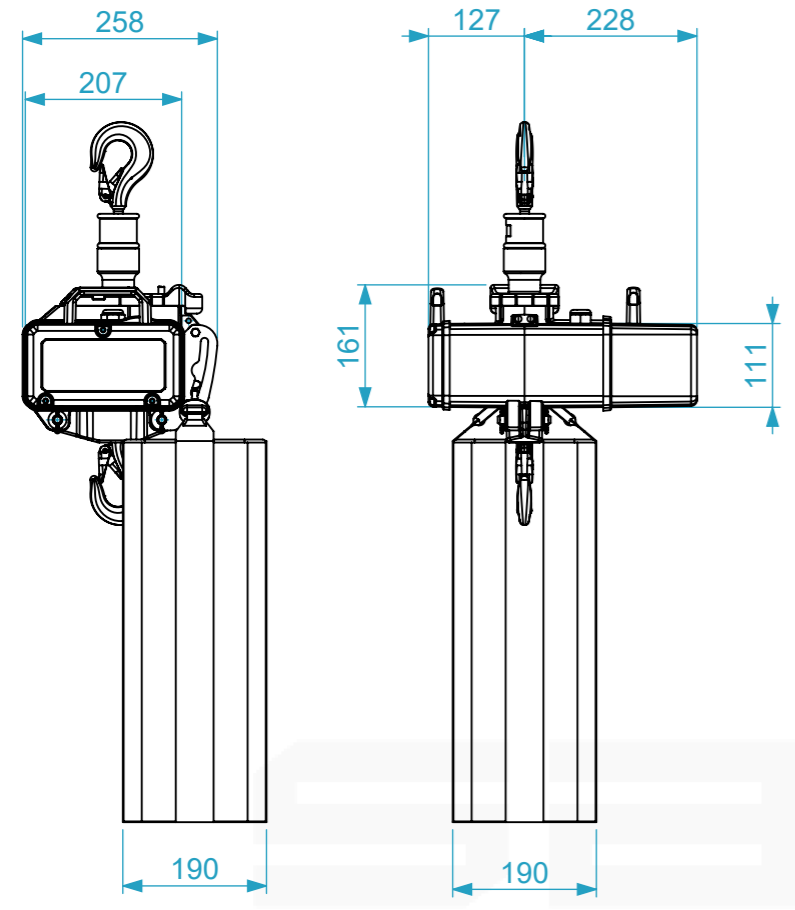

Cut-out for chain hook

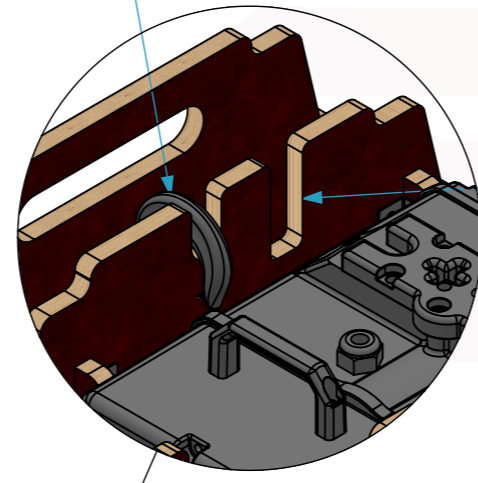

Cut-out for chain

Adjustable hoist mounts

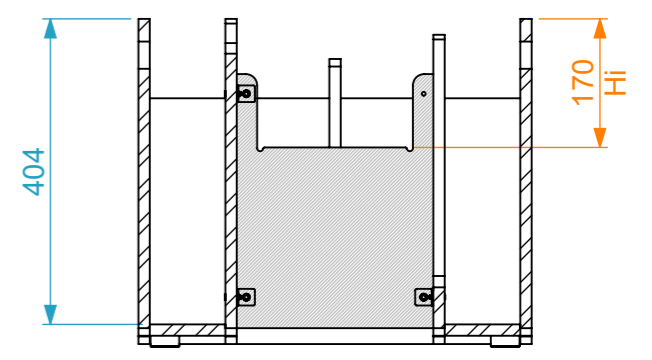
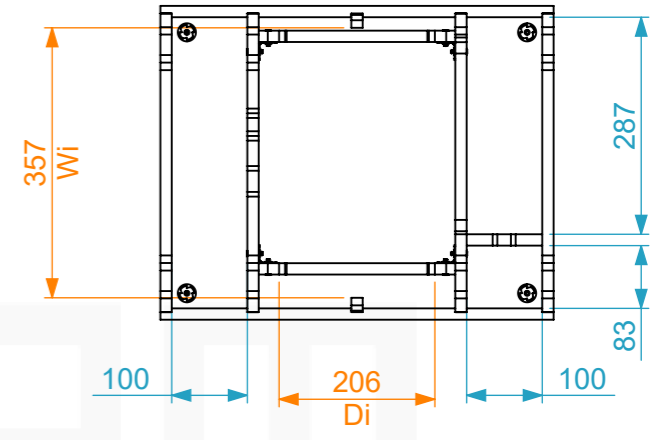
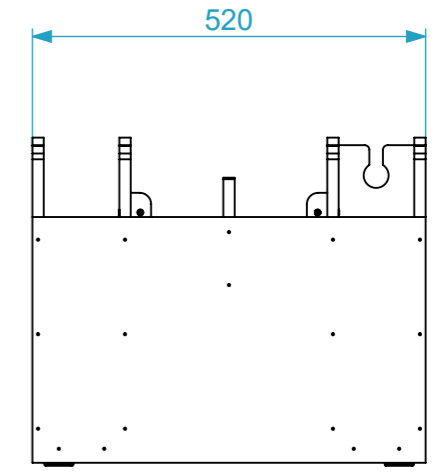
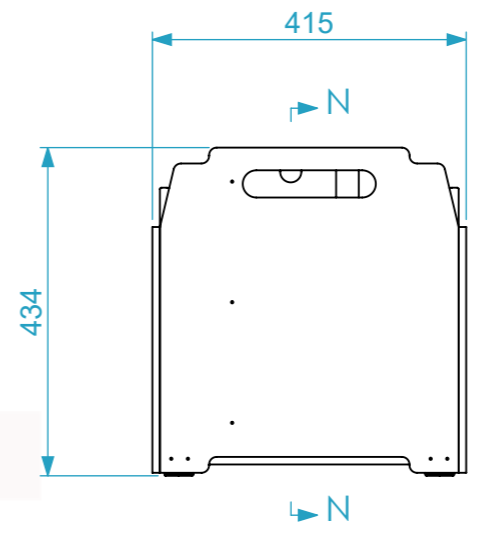
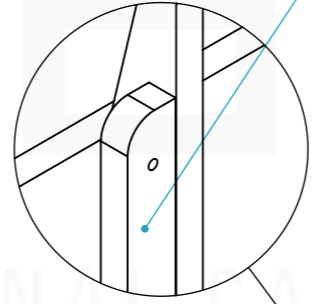

N-N

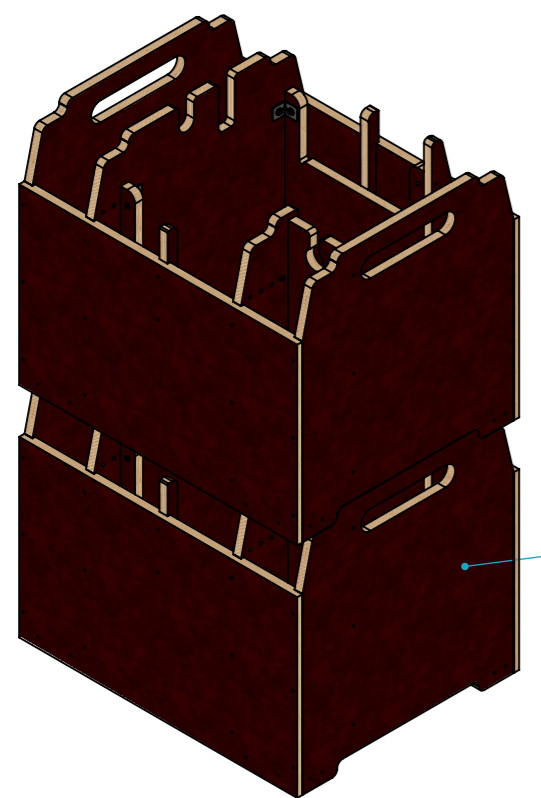

Stackable

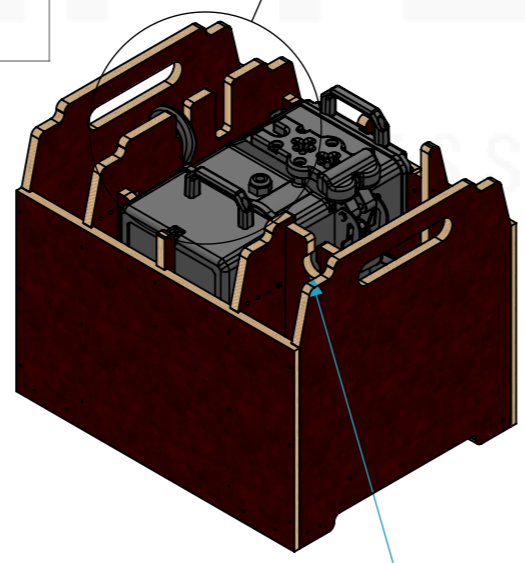

Cut-out for electrical cables

General External Dimensions		Usable Inner Dimensions		Wood Inner Dimensions	
W	Width	Wi	Inside Width	WWi	Wood Inside Width
D	Depth	Di	Inside Depth	WDi	Wood Inside Depth
H	Height	Hi	Inside Height	WHi	Wood Inside Height

This drawing must not be copied or disclosed without consent of the owner

Name	Date
alexandre	05/07/2022
Reference	BOX.0604848
Scale	1:10
units in mm	general tolerance 0.8mm
DO NOT SCALE	
Tabuleiro Motor 60.48.48 (355x205x170mm int.)	



A3