

Interior dimensions		
Width	Depth	Height
1020	550	855
Weight	Approx. 55 Kg	
Wall Thickness	9mm	

REVISIONS				
ZONE	REV.	DESCRIPTION	DATE	APPROVED
-	-	Final Drawing	10/10/2014	Daniel Lopes

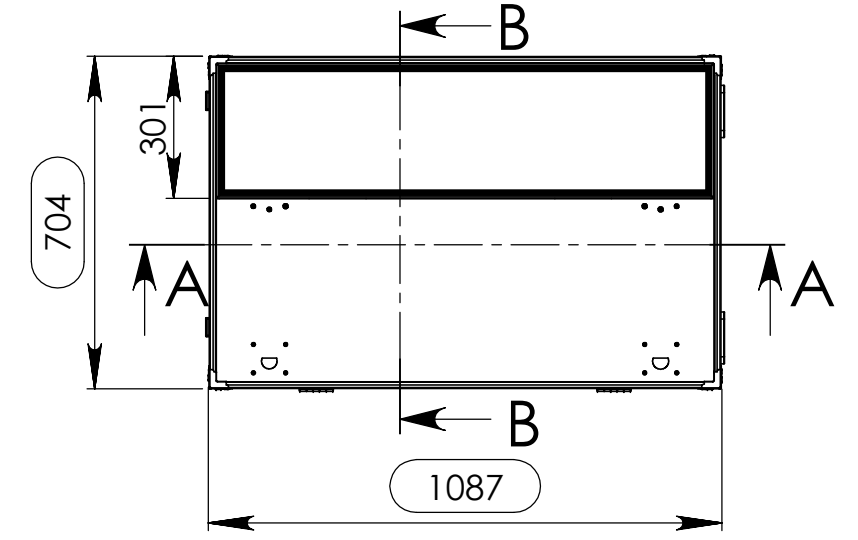
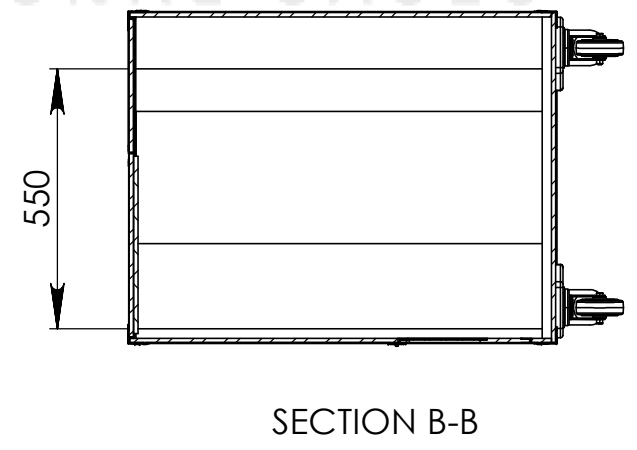
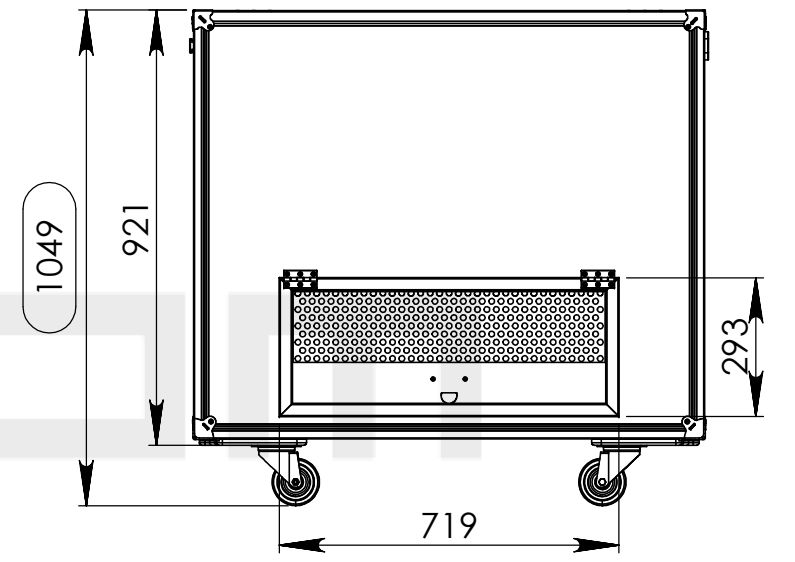
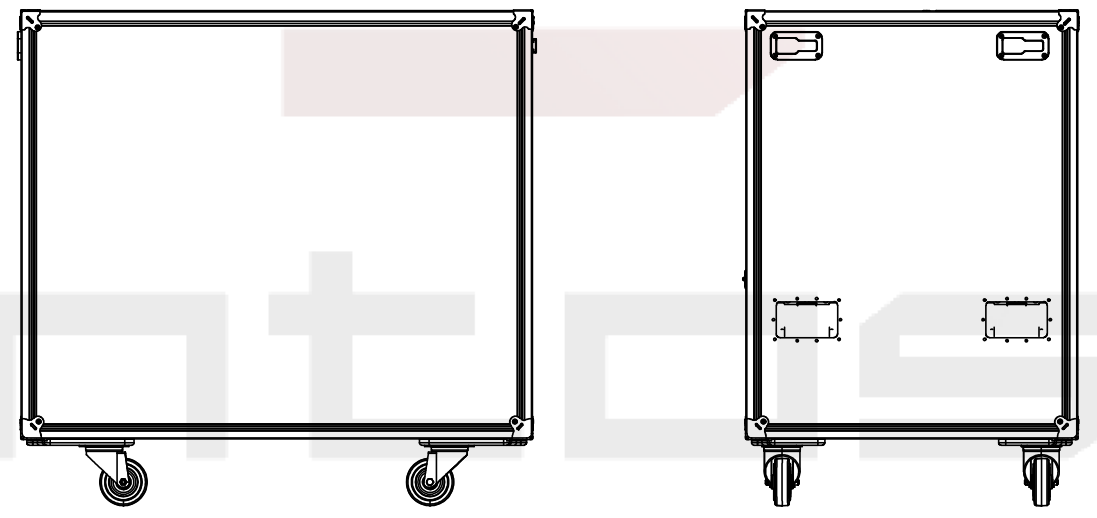
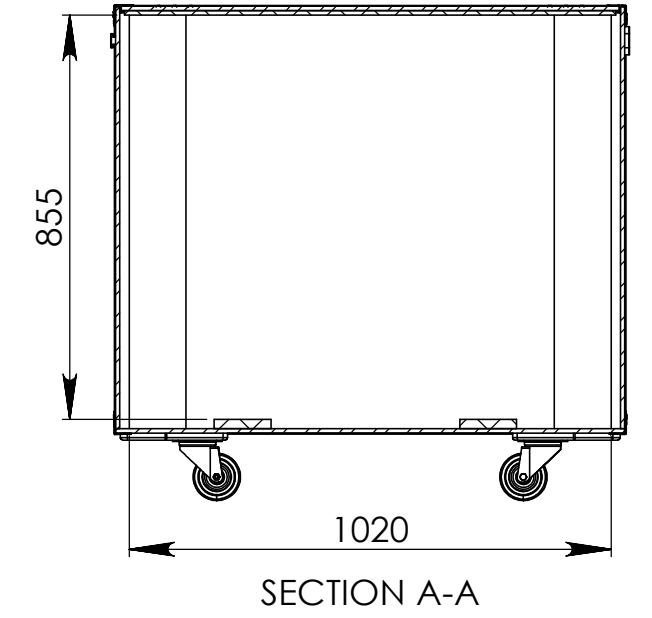
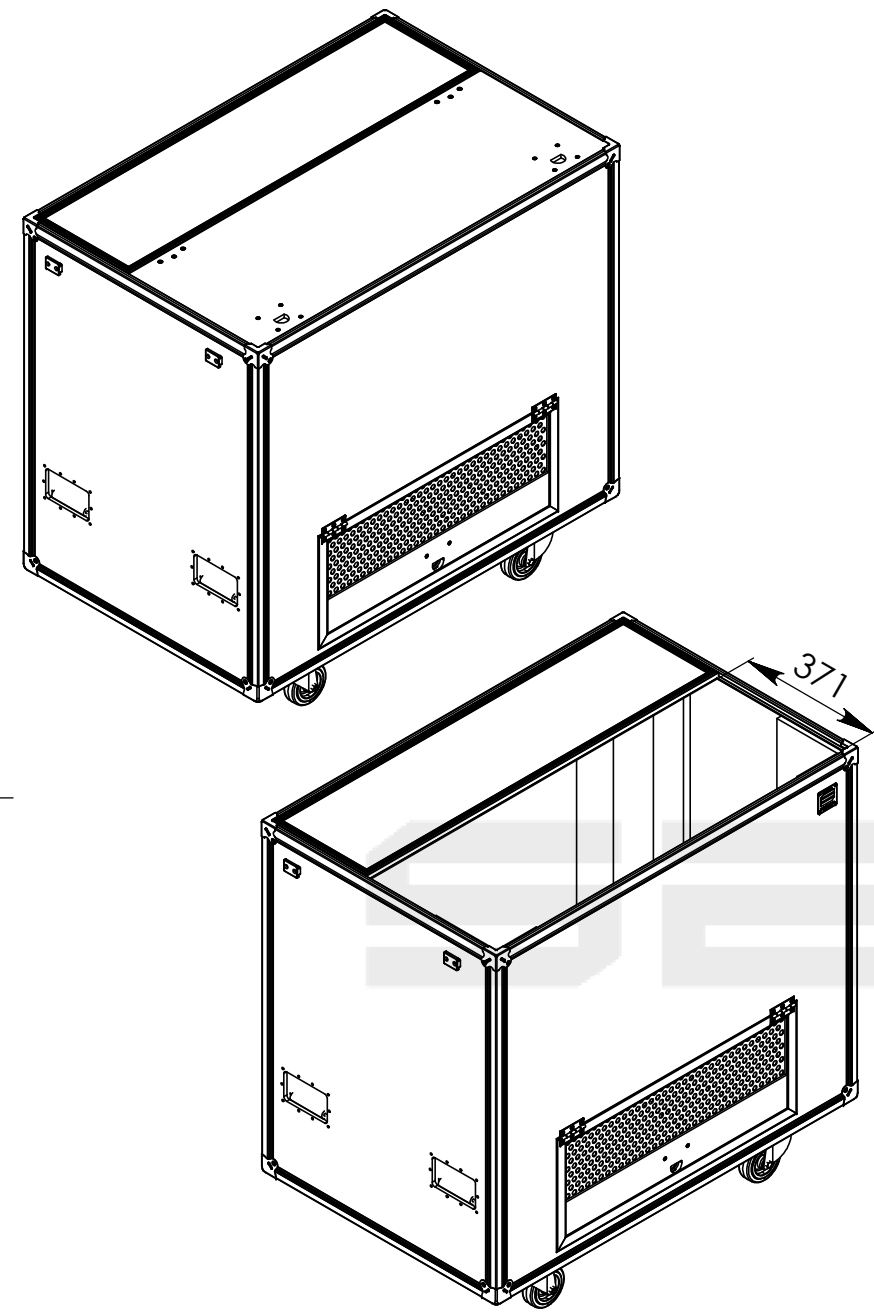

Hardware		
Qty	Ref.	Description
3	16540	Sliding Latch System - Sliding Latch
4	34082	Recessed sprung handle medium model
4	C0675-30Z	UX-BOX, Corner 2 LEG, 10mm
4	4004	Case corner zinc plated
4	RODA.100	Swivel castor Ø100 mm
2	2602	Medium duty butt hinge z./p.

This drawing must not be copied or disclosed without consent of the owner

Drawn by	DanielLopes	Date	13-10-2014
Reference	BAR.100R1		
Scale	1:16	units in mm	general tolerance 0.8mm
		DO NOT SCALE	
	FC, Arca Frigorifica AUDIOFLAT SUB 5812		

