

### Interior dimensions

Width	Depth	Height
19"	1000	14 Un
Weight	Approx. 64 Kg	
Wall Thickness	10mm	

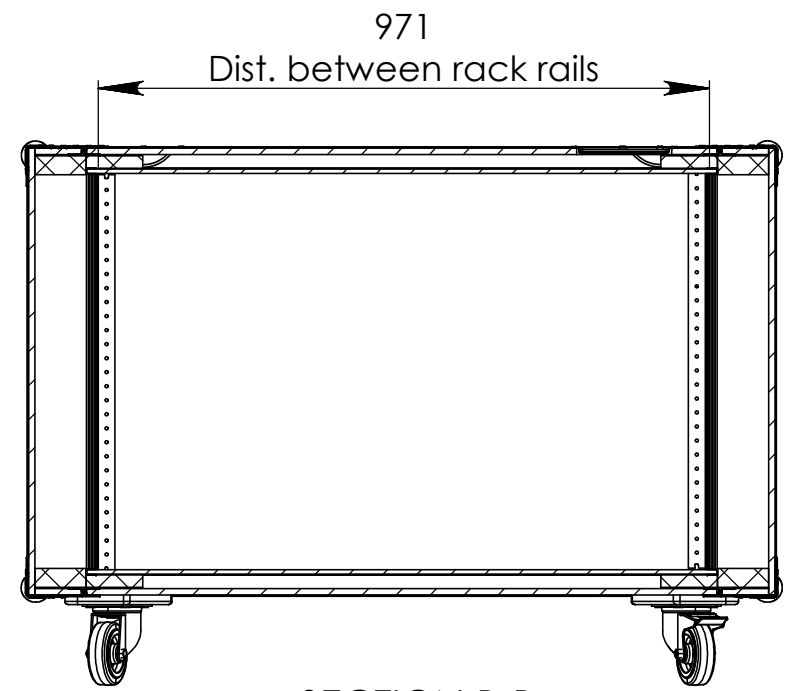

SECTION B-B

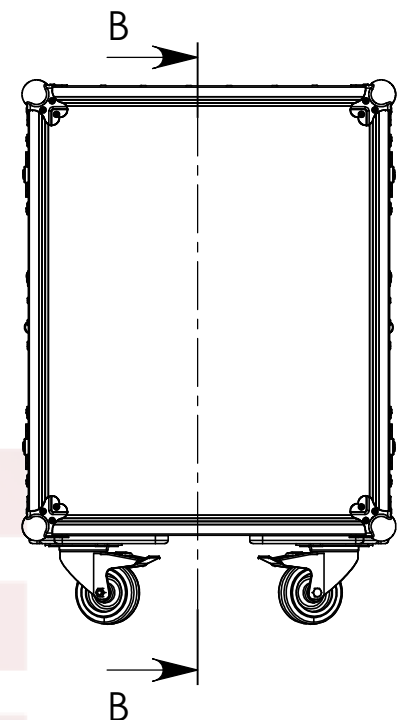
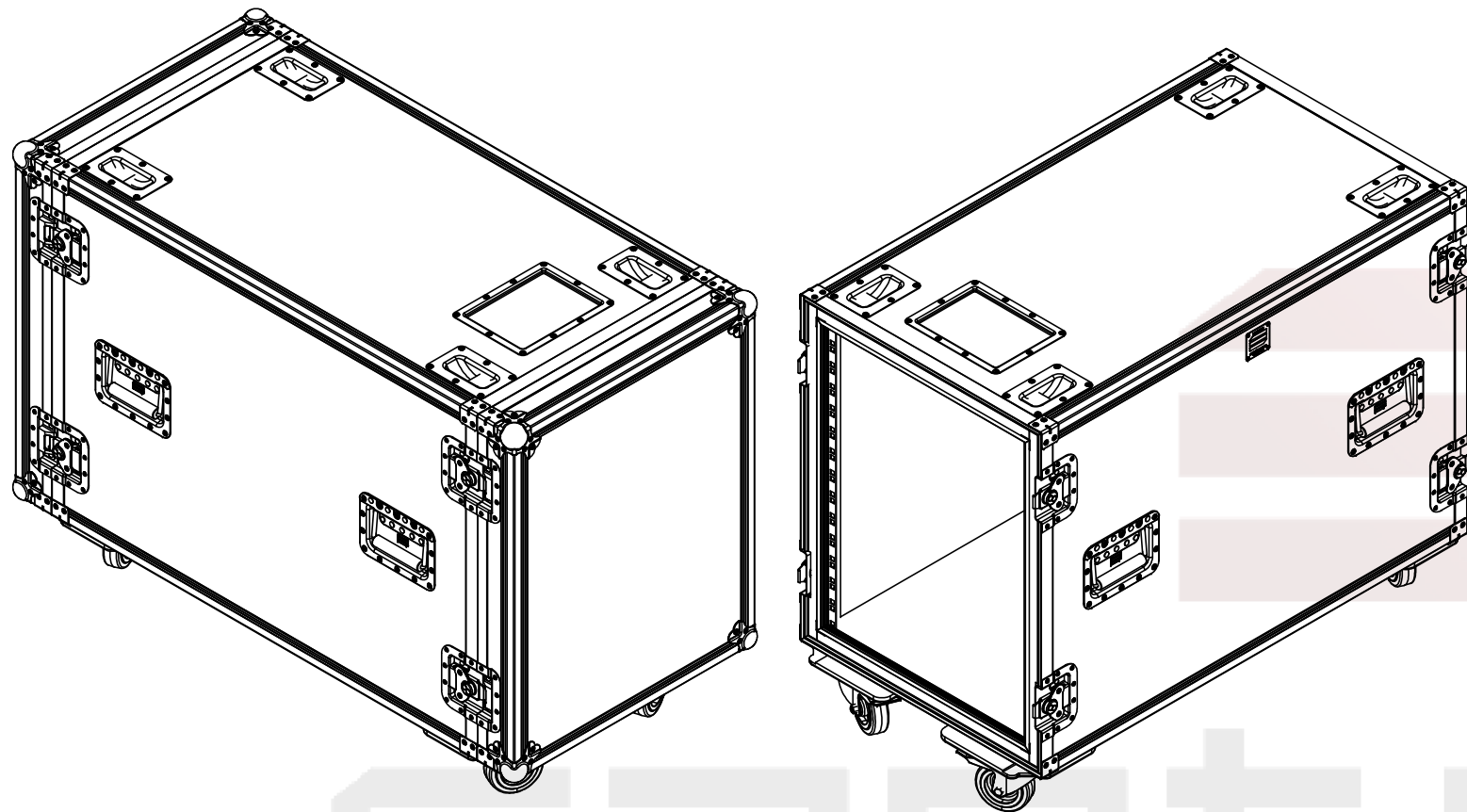
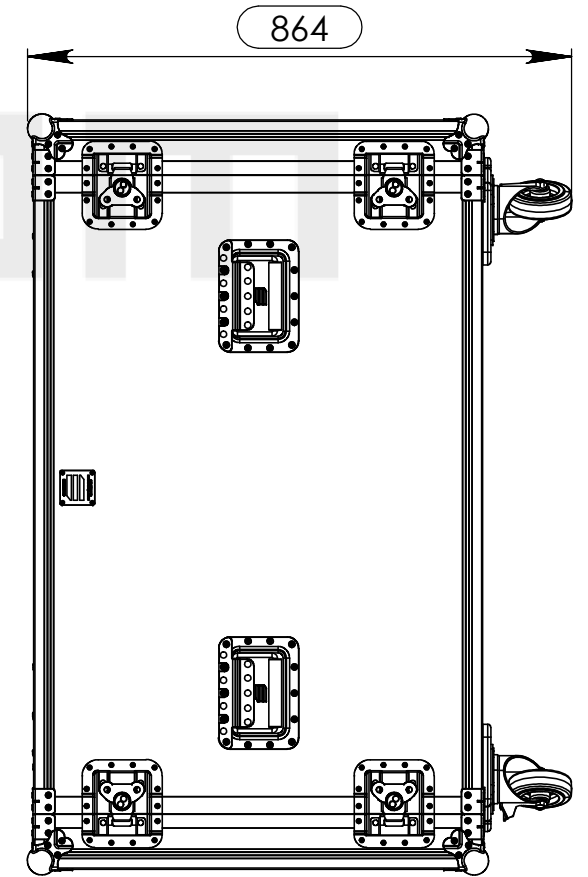
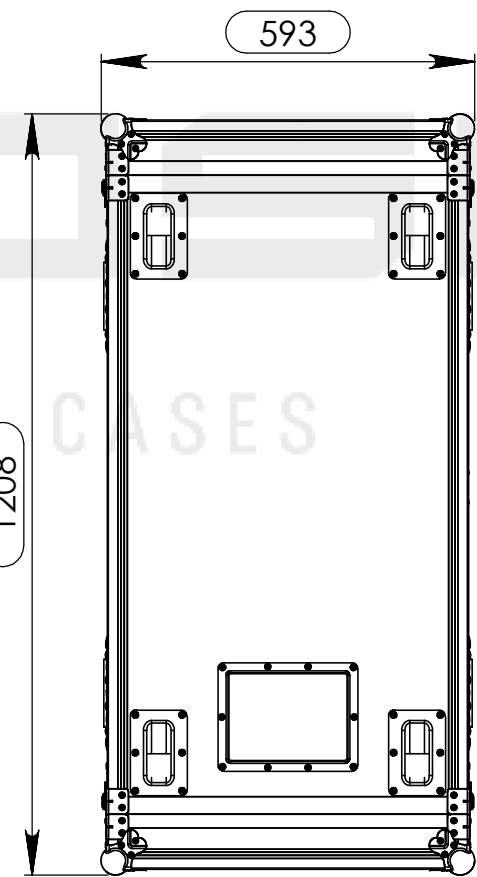

### Hardware

Qty	Ref.	Description
8	40407	Medium corner-brace zinc plated 1,0mm
2	RODAS.1001	Castor plate wood black
2	RODAS.1001	Castor plate wood black
16	40403	Large corner bracket f. 35mm case angle
8	4101	Heavy Duty Ball Corner
4	4909	38 mm rubber foot black with steel insert
1	CHAPA.1000	Identification Plate
4	38083	Castor dish deep zinc plated
2	RODA.100T	Swivel castor Ø100mm with brake
2	RODA.100	Swivel castor Ø100 mm
1	88001D	Dish for 88001 Tour Label
4	34085	Large, heavy duty, recessed sprung handle
8	172531	Large butterfly V3 with 'push-back' function

This drawing must not be copied or disclosed without consent of the owner

Drawn by	Name	Date
projects		24/08/2016
Reference	AS2T.14100R	
Scale	units in mm	general tolerance
1:12	DO NOT SCALE	0,8mm
RACK 2T ANTI-SHOCK 19" 14U 1000, RODAS		

