

Internal Dimensions		
Width	Depth	Height
19"	490	2 Un
Weight	Approx. 15 Kg	
Wall Thickness	7mm	

REVISIONS			
REV.	DESCRIPTION	DATE	APPROVED
1	Increase of 10 mm in the height of the FC and 5 mm on the depth of both lids and on the height of the rack module inside	03/03/2017	Alexandre

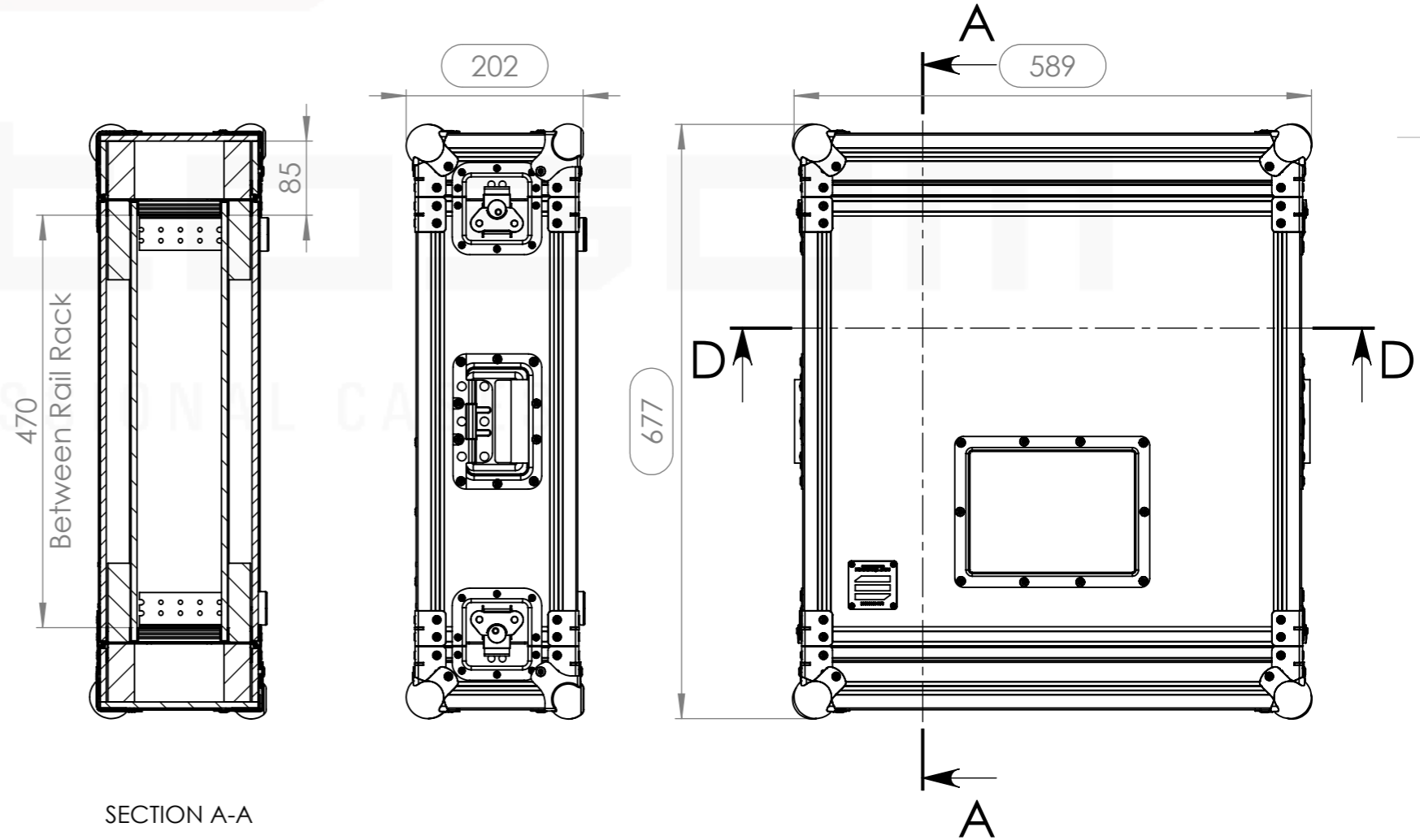
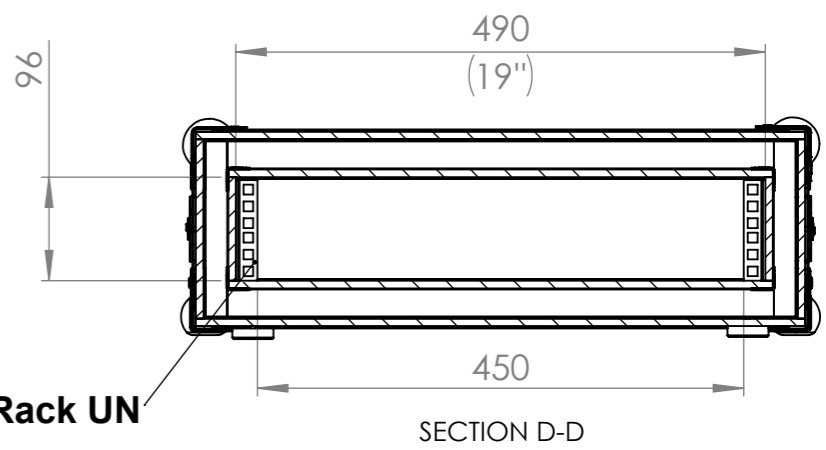
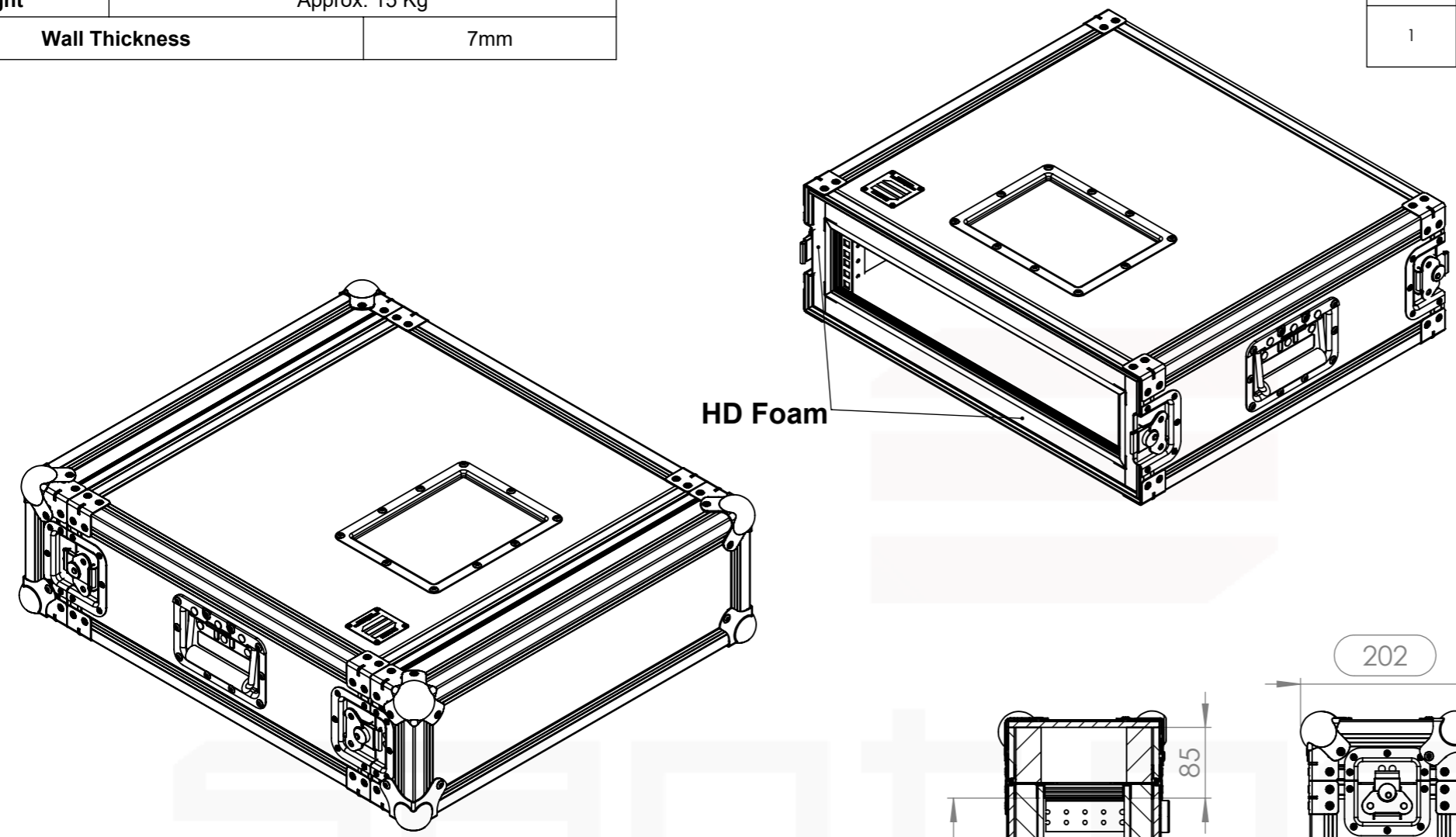

Hardware		
Qty	Ref.	Description
16	40403	Large corner bracket f. 35mm case angle
4	4120	Heavy duty ball corner, zinc plated
8	40407	Medium corner-brace zinc plated 1,0mm
1	88001D	Dish for 88001 Tour Label
2	34082	Recessed sprung handle medium model
4	17290S	Key lockable medium Butterfly special
4	4122	Medium ball corner zinc plated with stacking dimple
4	PRUMO.1005	Single Racks Strip 1/2U 2mm
1	CHAPA.1000	Identification Plate
4	4906	38 mm rubber foot black H:10 mm.

Drawn by	Name	Date
projects	projects	20/03/2017
Reference	AS2T.0250	
Scale	units in mm	general tolerance
1:7	DO NOT SCALE	0.8mm
SANTOSOM 19" RACK DD, ANTI-SHOCK 2U 500		



This drawing must not be copied or disclosed without consent of the owner

A3

