

Internal Dimensions		
Width	Depth	Height
19"	512	2Un
Weight	Approx. 6 Kg	
Wall Thickness		7mm

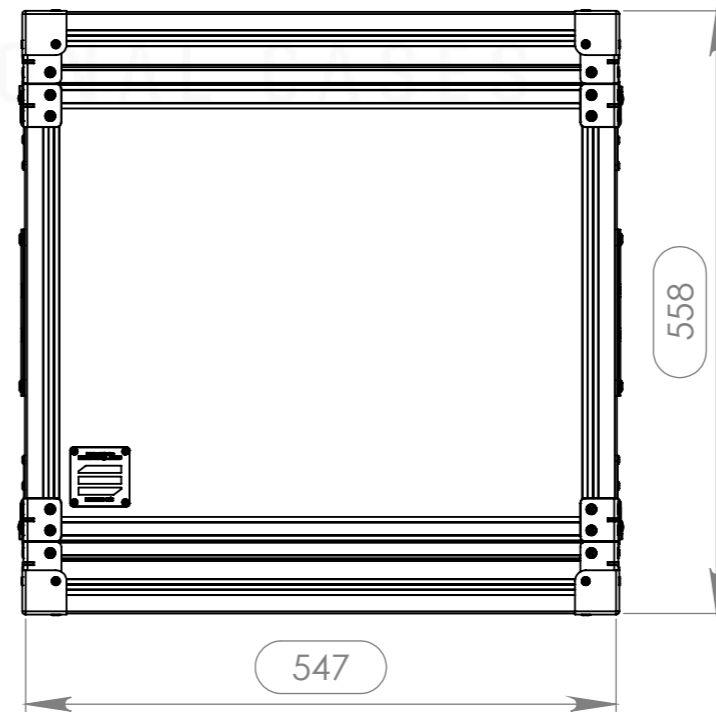
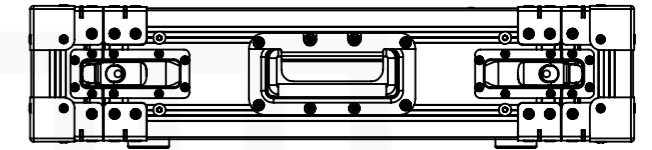
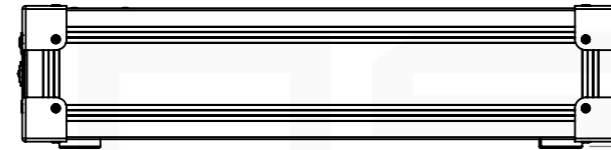
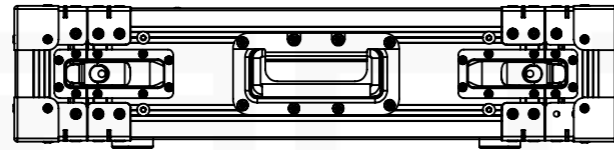
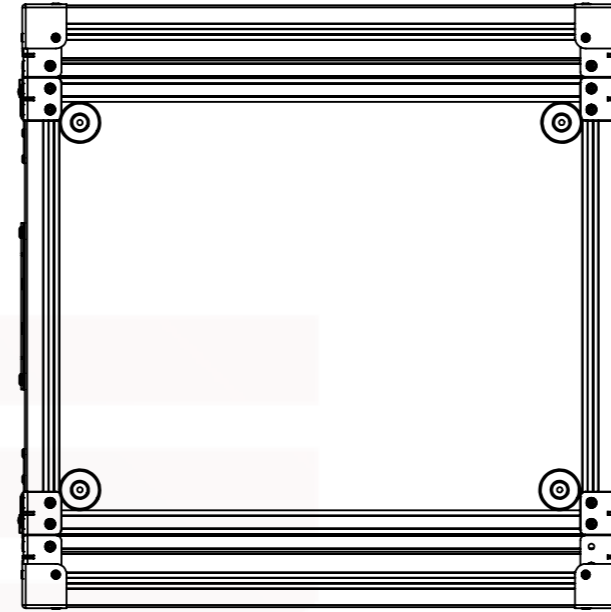
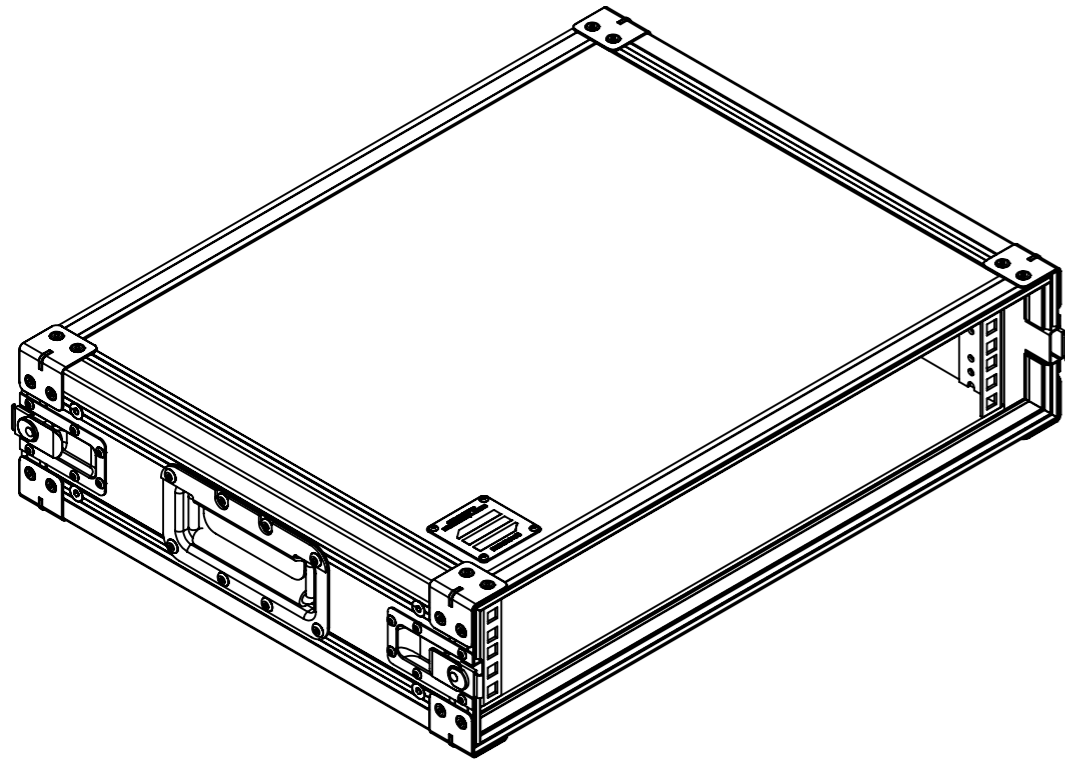

Hardware		
Qty	Ref.	Description
1	CHAPA.1000	Identification Plate
8	40403	Large corner bracket f. 35mm case angle
8	AMORT.2020	Shock mount buffer Ø20x20 FF M6
4	17202	2U Butterfly Latch
4	PRUMO.1005	Single Racks Strip 1/2U 2mm
8	4001	SQUARE CASE/CABINET CORNER
2	340822	Recessed sprung handle - Small
6	40403	Large corner bracket f. 35mm case angle
2	40403	Large corner bracket f. 35mm case angle
4	4906	38 mm rubber foot black H:10 mm.

This drawing must not be copied or disclosed without consent of the owner

Drawn by	Name	Date
jorgepacheco	jorgepacheco	24/03/2017
Reference	AS2LW.0241	
Scale	units in mm	general tolerance
1:7	DO NOT SCALE	0.8mm
LW RACK DD. ANTI-SHOCK 19' 2U		

