

Interior dimensions		
Width	Depth	Height
720	505	230
Weight	Approx. 16 Kg	
Wall Thickness	7mm	

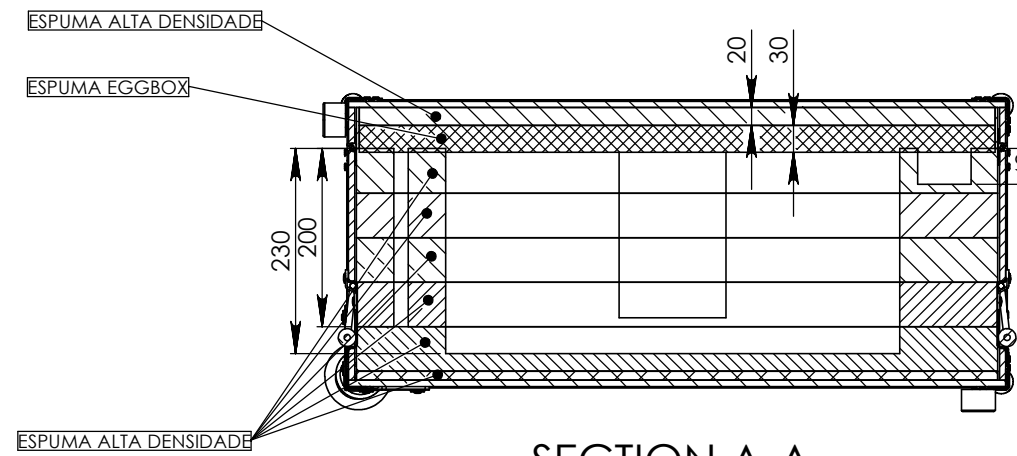
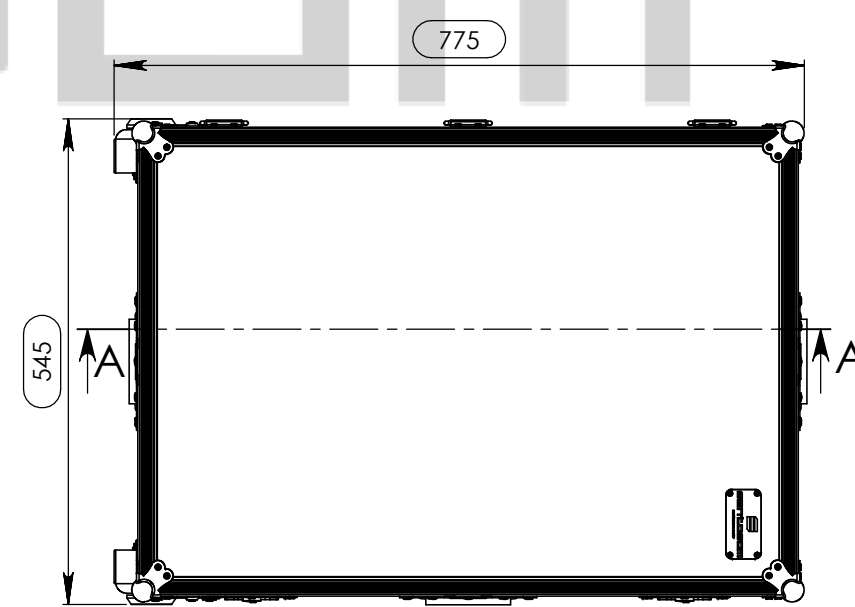
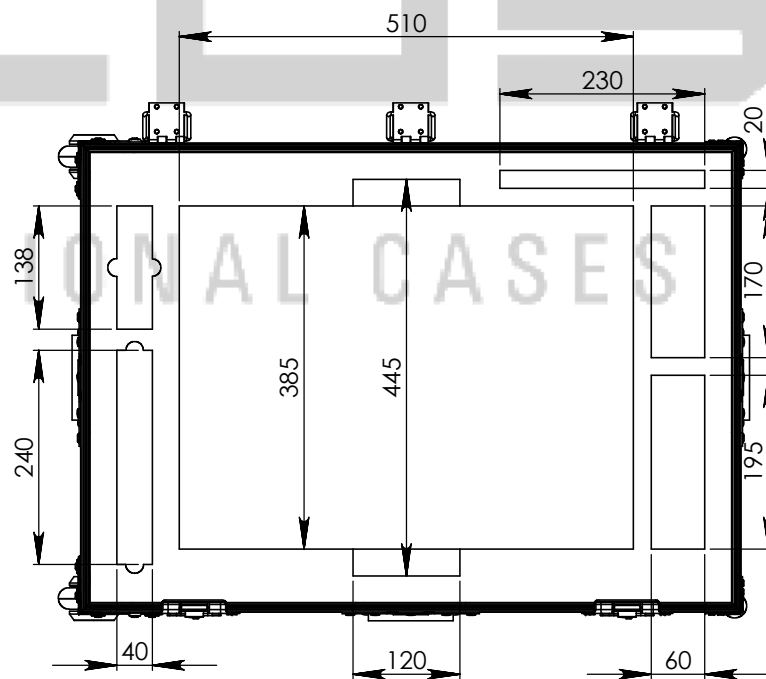
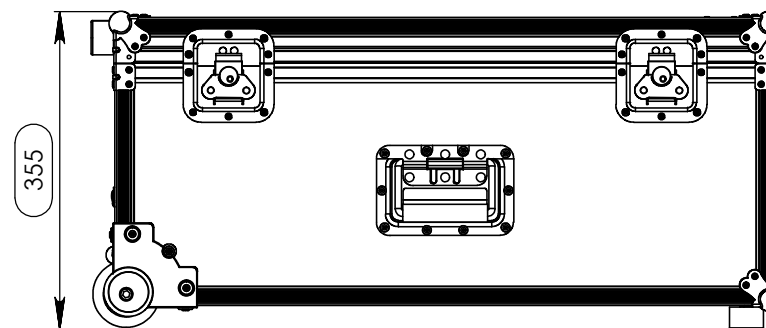
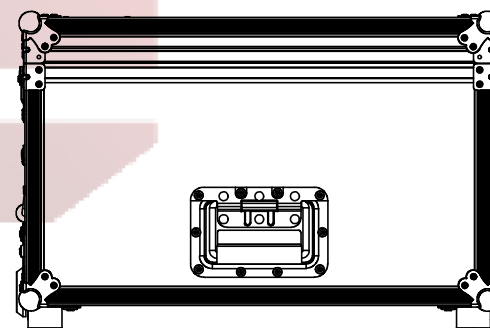
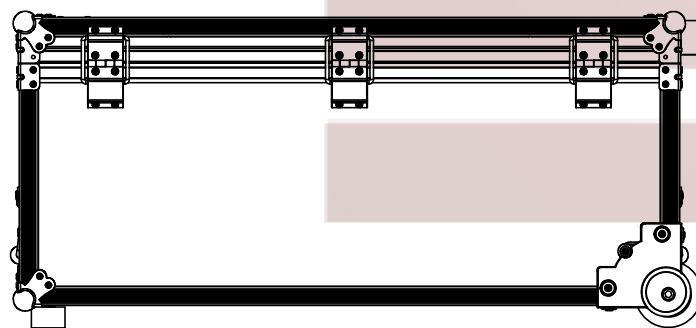
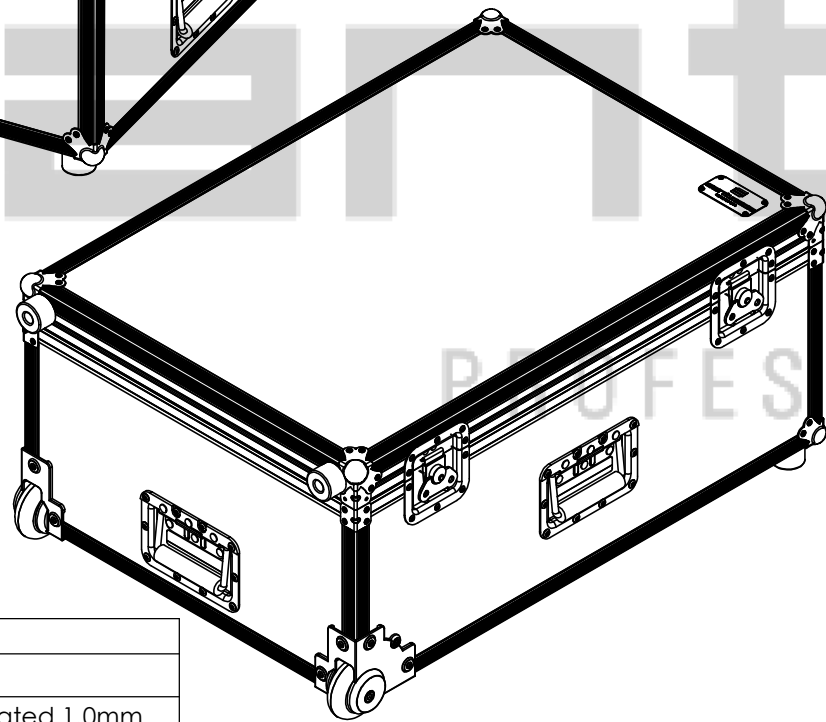
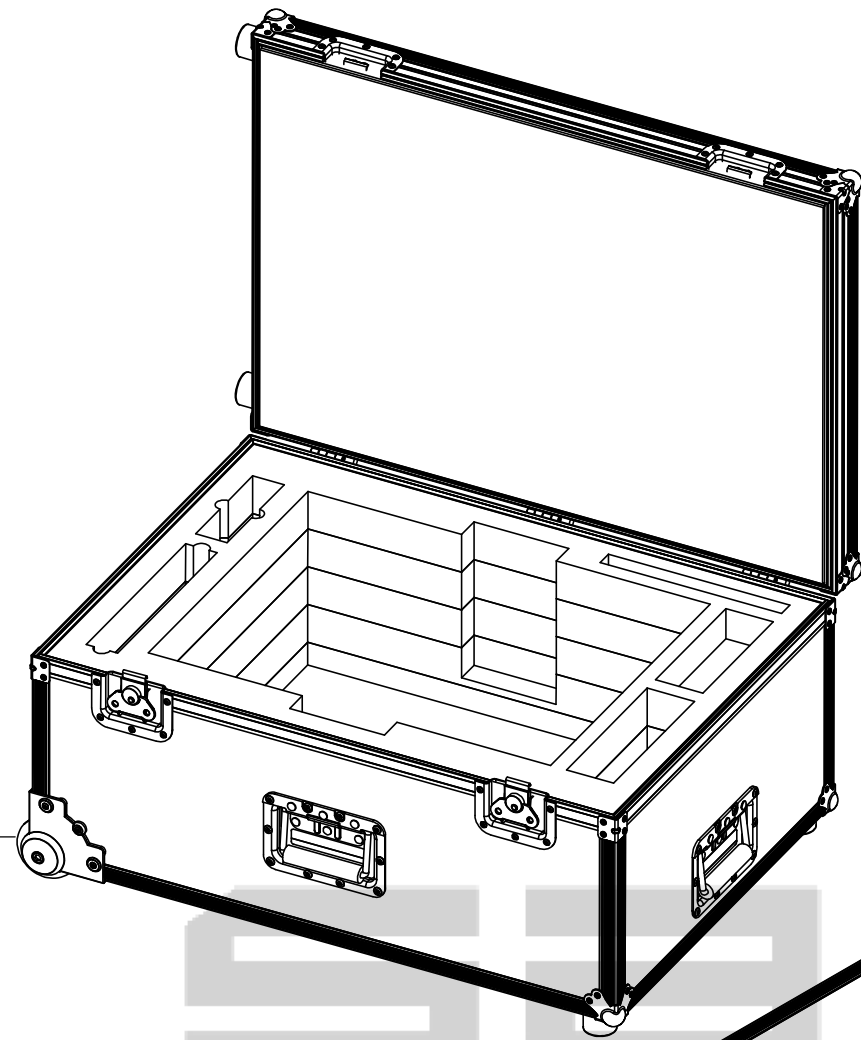

SECTION A-A

Hardware	
Qty	Description
4	Medium corner-brace zinc plated 1,0mm
4	Medium corner-brace zinc plated 1,0mm
4	Rubber foot 38 x 25 mm with steel insert
6	Small ball corner - 3 leg - zinc plated
3	Recessed sprung handle medium model
3	Heavy Duty Strut Hinge, zinc plated
2	Recessed Corner Castor 75mm, Die-Cast Housing
2	Key lockable medium Butterfly special

Name	Date
Drawn by: DanielLopes	27-06-2012

Reference	ALPAL003
Scale	1:6
1st Angle projection	

This drawing must not be copied or disclosed without consent of the owner



127000101-0000
DO NOT SCALE
general tolerance
0,08mm
Flightcase, CroScan 2000F, 720x505x230mm

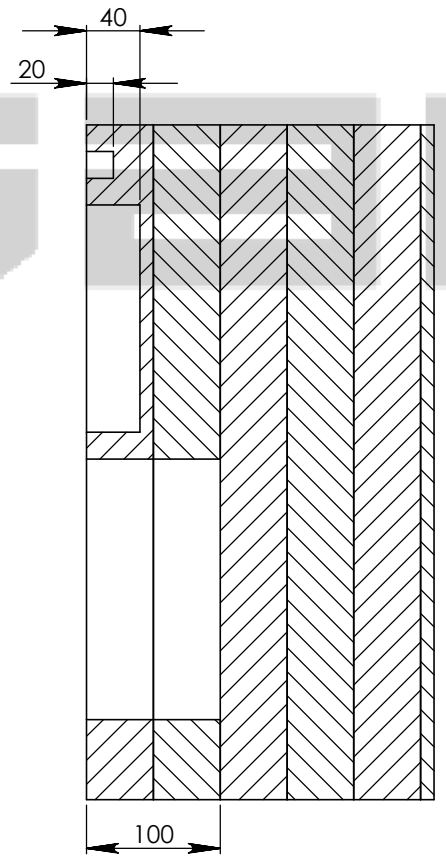
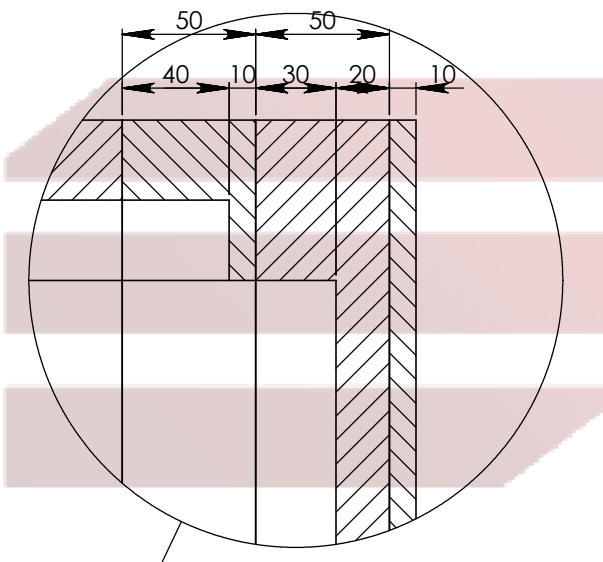
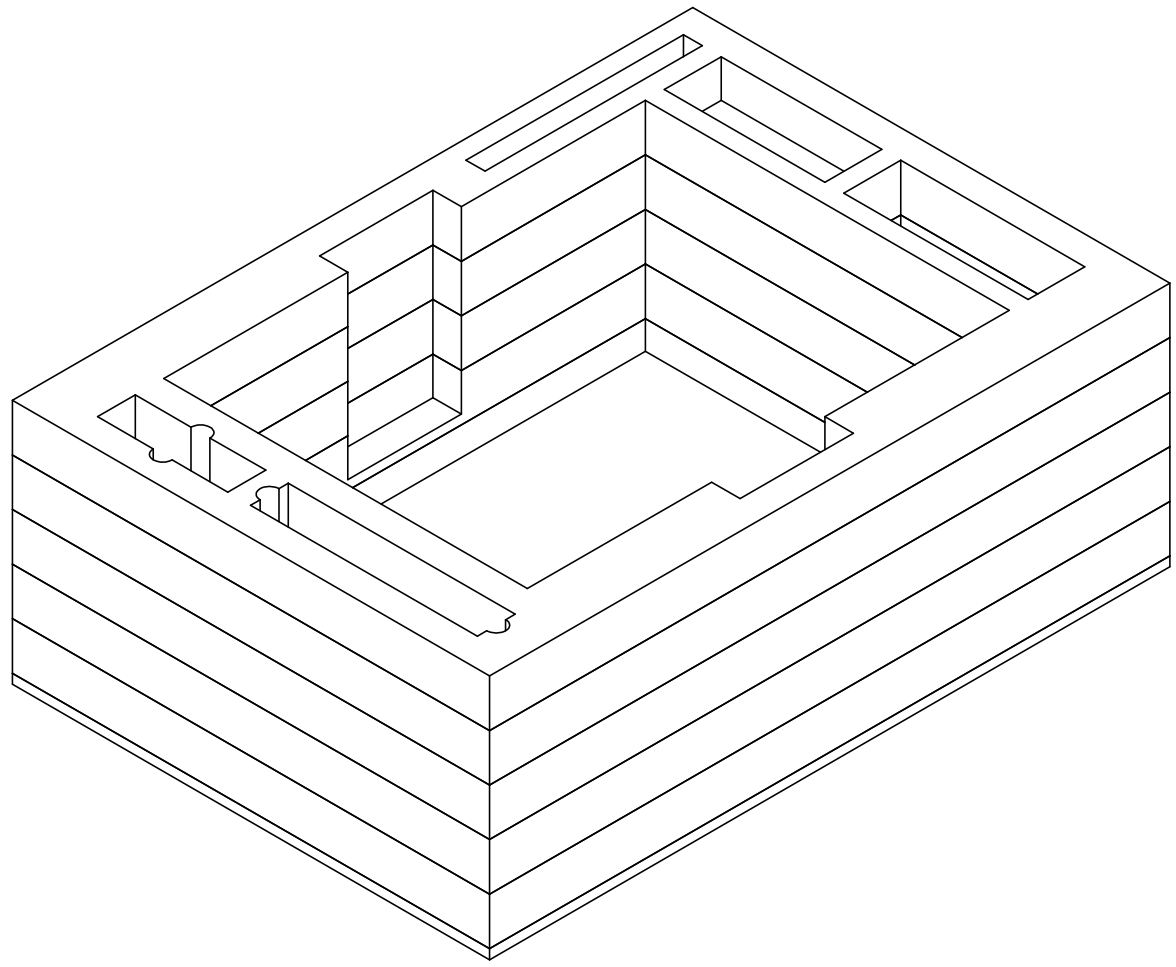

SECTION D-D

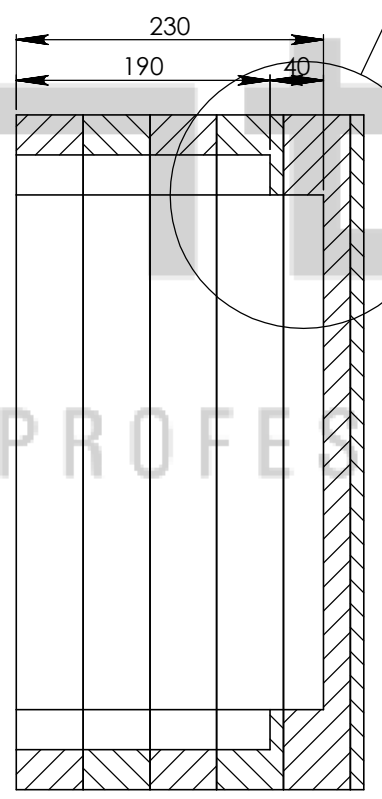

SECTION C-C

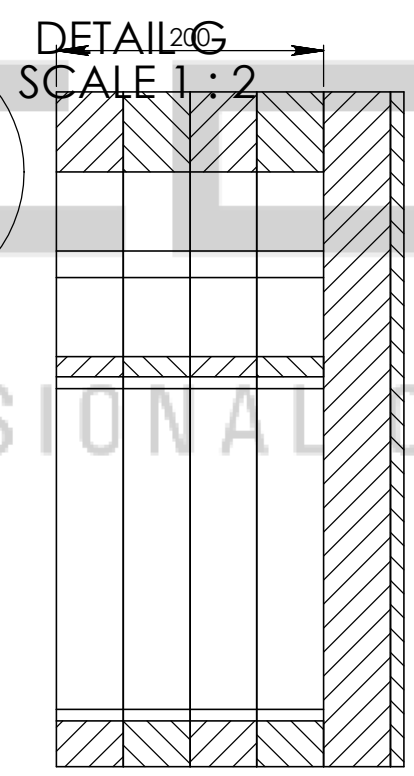

SECTION B-B

DETAIL SCALE 1:2

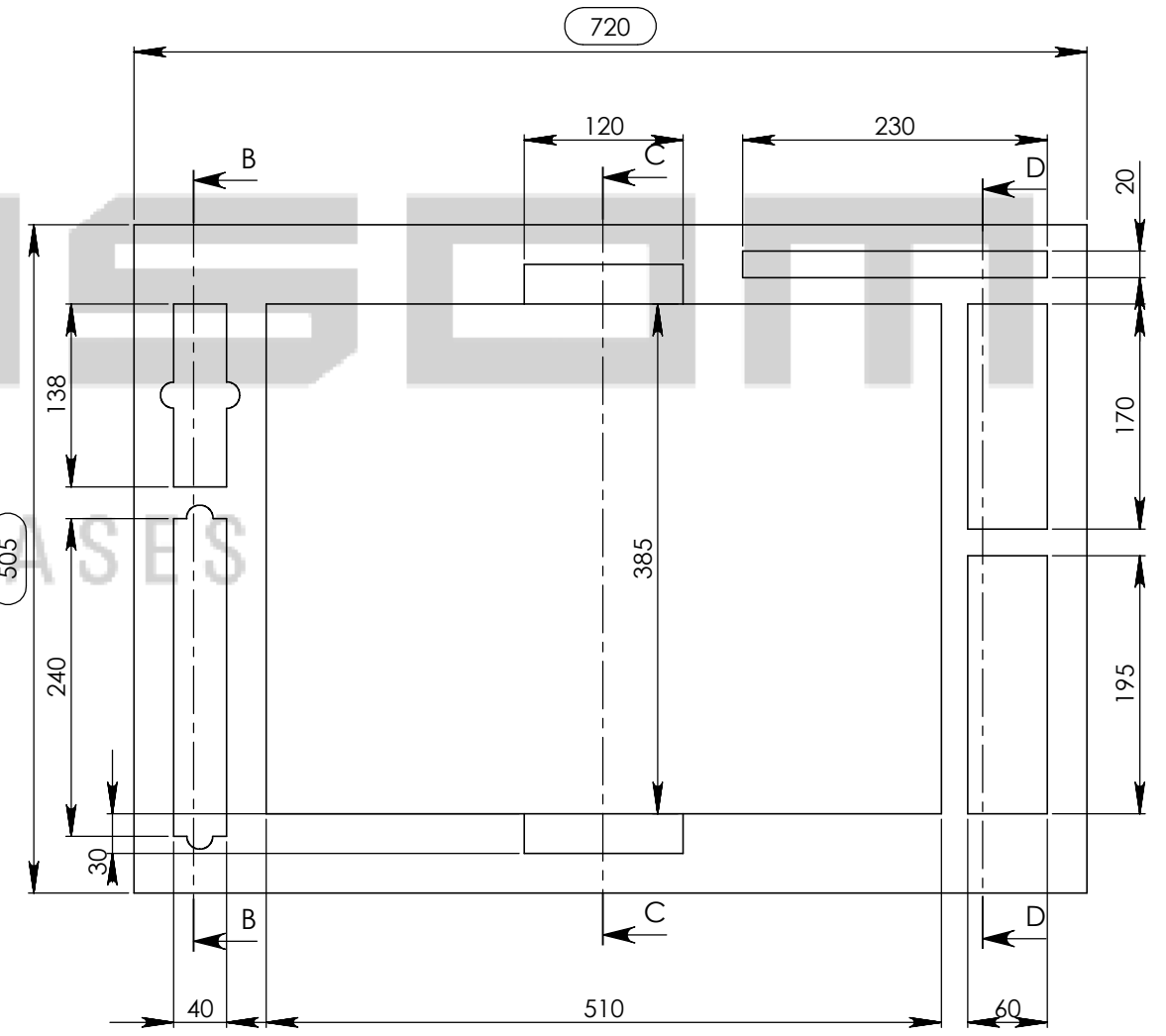

Drawn by	Name	Date
Daniel Lopes	Daniel Lopes	27-06-2012
Reference	ALPAL003	
Scale	1:4	general tolerance 0.08mm
1st Angle projection		

This drawing must not be copied or disclosed without consent of the owner

Rightcase, CropScan 2009F, 720x505x273mm

14-11121-001 2011