

Interior dimensions		
Width	Depth	Height
19"	550	14Un
Weight	Approx. 38 Kg	
Wall Thickness	9mm	

REVISIONS				
ZONE	REV.	DESCRIPTION	DATE	APPROVED
-	-	Final Drawing	02/10/2013	Daniel Lopes

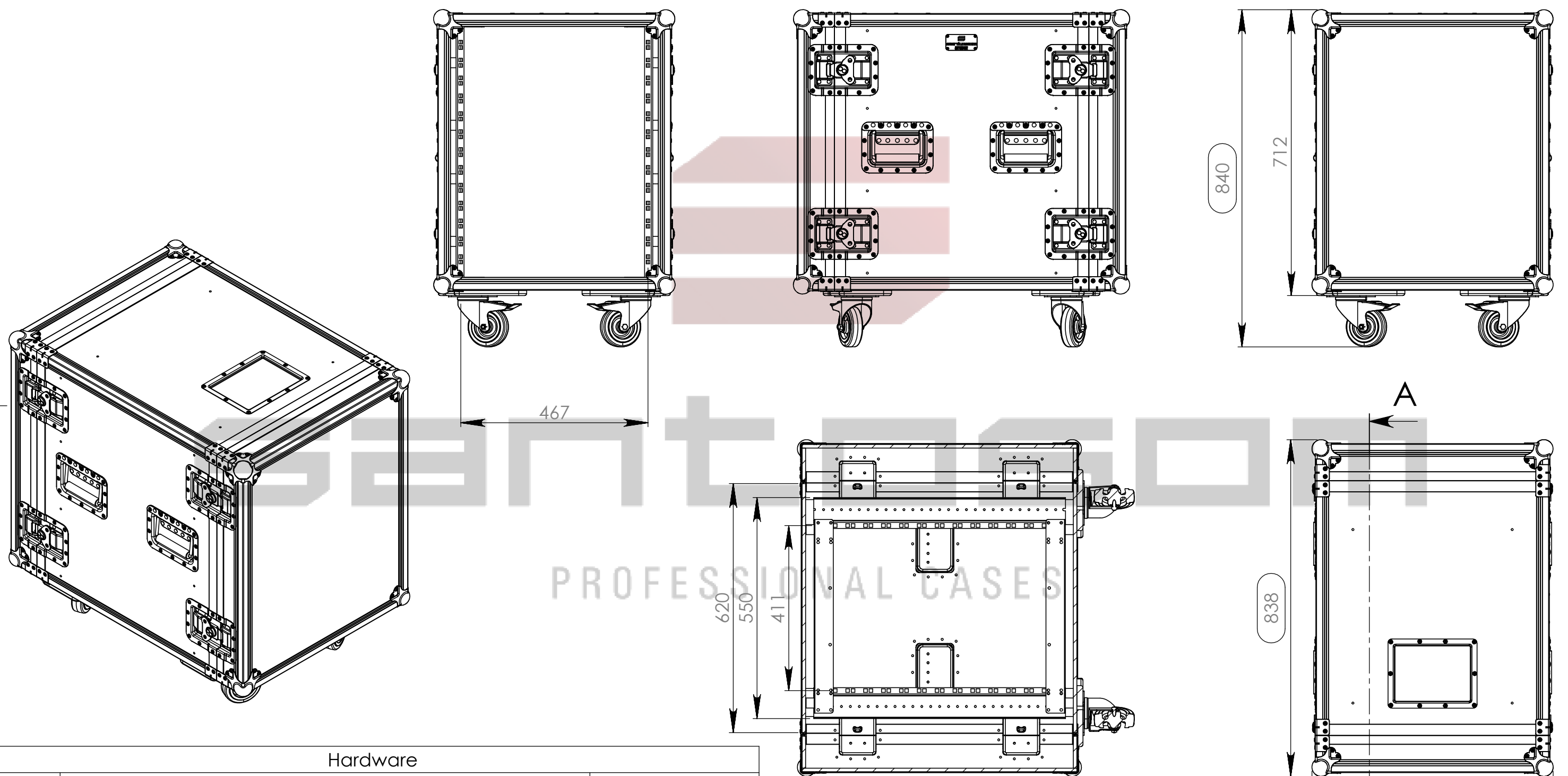

Hardware		
Qty	Description	Ref.
16	Large corner bracket f. 35mm case angle	40403
8	Heavy Duty Ball Corner	410429
2	Swivel castor Ø80 mm	RODA.100
2	Swivel castor Ø80 mm with brake	RODA.100T
4	Large, heavy duty, recessed sprung handle	34085
8	Large AH butterfly with 'push-back' function in 14mm dish	172511COMP
1	Dish for 88001 Tour Label	88001D

Name	Date
Drawn by: Daniel Lopes	02-10-2013
Reference	AF2T.1455R1
Scale	1:10
units in mm	general tolerance 0.8mm
DO NOT SCALE	
1st Angle projection	RACK, 19" 2 TAMPAS 14 U 550 PROF., RODAS



This drawing must not be copied or disclosed without consent of the owner

A3