

Interior dimensions

Width	Depth	Height
2000	350	520
Weight	Approx. 31 Kg	
Wall Thickness	7mm	

REVISIONS

ZONE	REV.	DESCRIPTION	DATE	APPROVED
-	0	Final Drawing	14/11/2015	Carlos Rodrigues

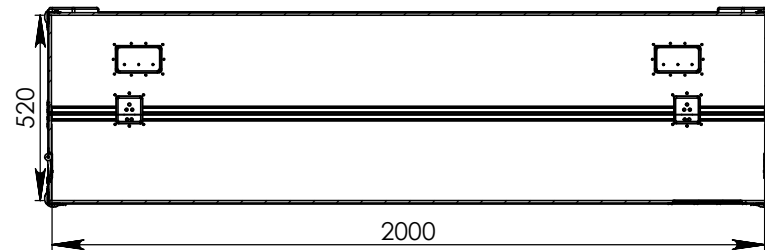

SECTION B-B

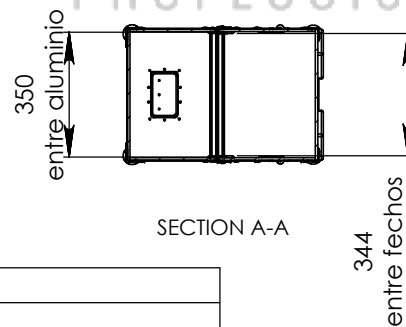
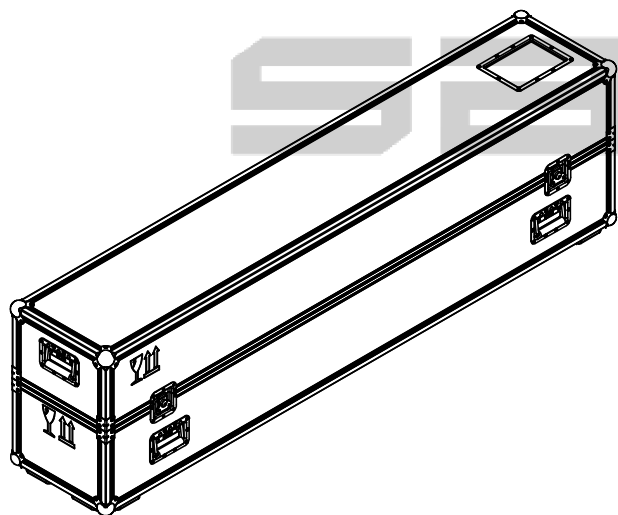
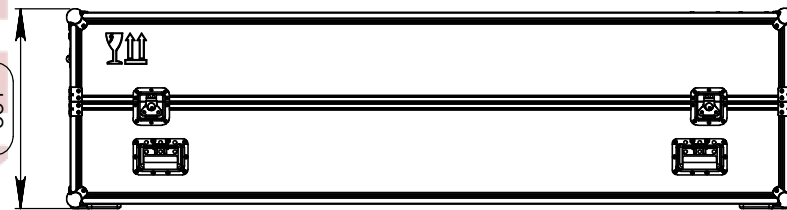
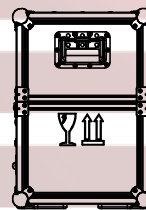
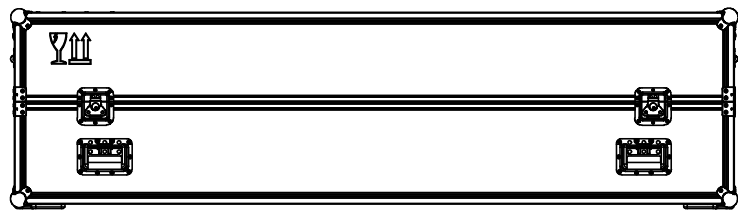

SECTION A-A

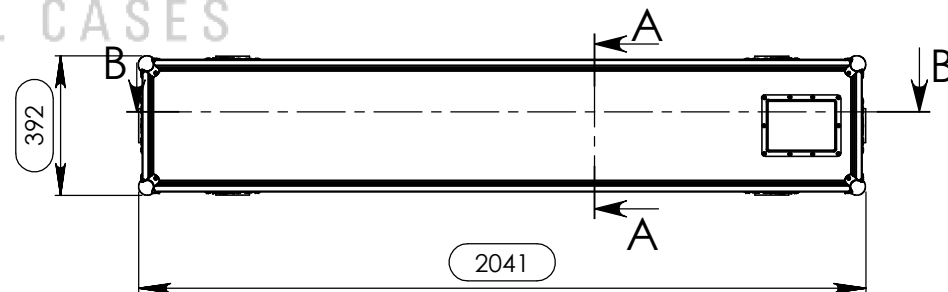

Hardware

Qty	Ref.	Description
8	40403	Large corner bracket f. 35mm case angle
4	17290S	Key lockable medium Butterfly special
6	34082	Recessed sprung handle medium model
8	4120	Medium ball corner zinc plated
1	88005D	Dish for 88001 Tour Label

This drawing must not be copied or disclosed without consent of the owner



Scale 1:15

units in mm DO NOT SCALE general tolerance 0.8mm

FC. SUBMERCIVEL III 2240X350X520

