

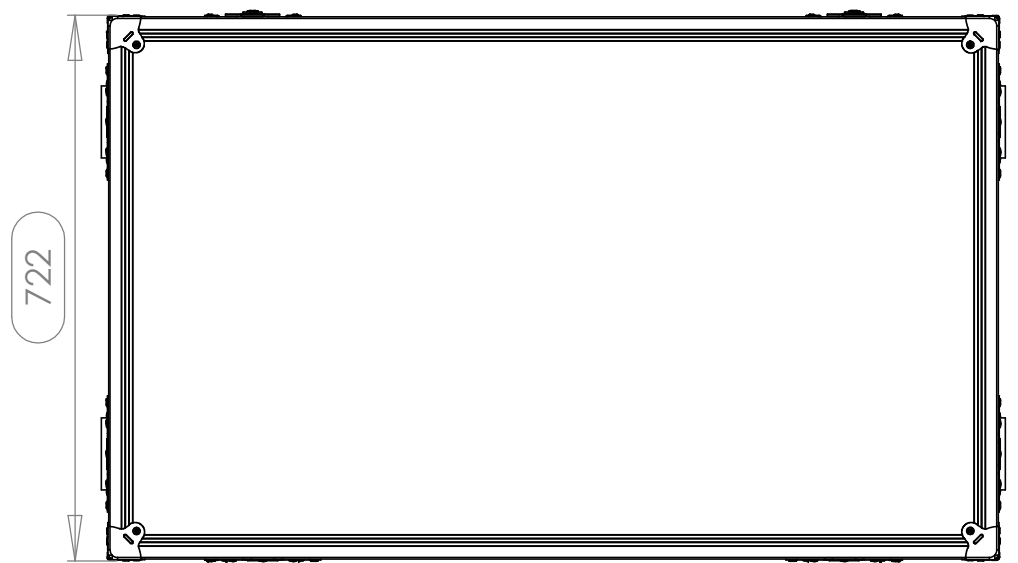

Interior dimensions		
Width	Depth	Height
1110	650	560
Weight	Approx. 41 Kg	
Wall Thickness	10mm	

REVISIONS				
ZONE	REV.	DESCRIPTION	DATE	APPROVED
-	0	Final Drawing	10/12/2014	Carlos Rodrigues

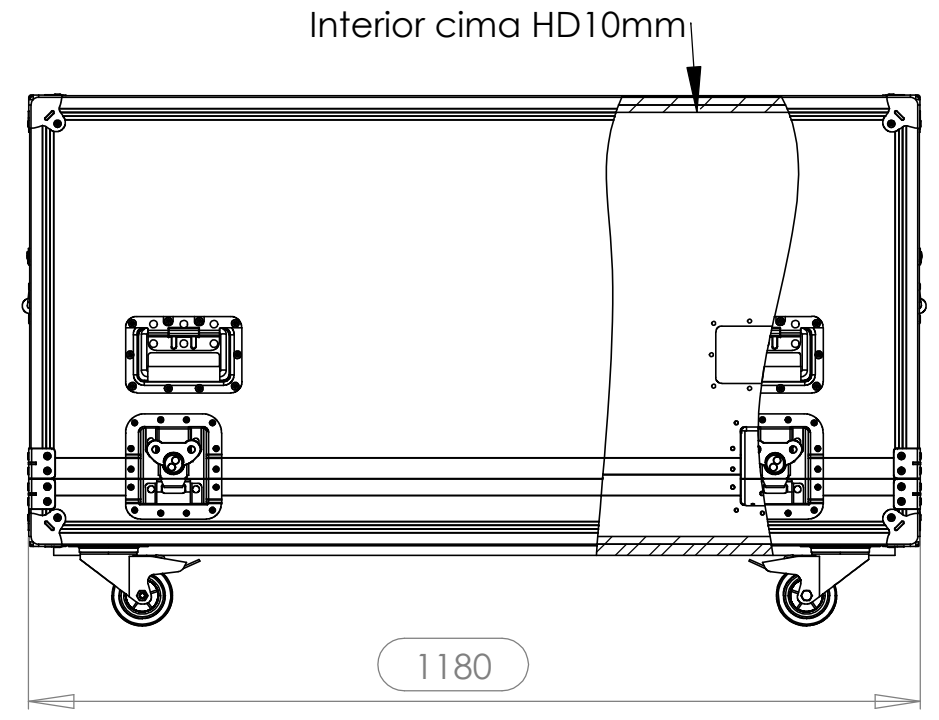
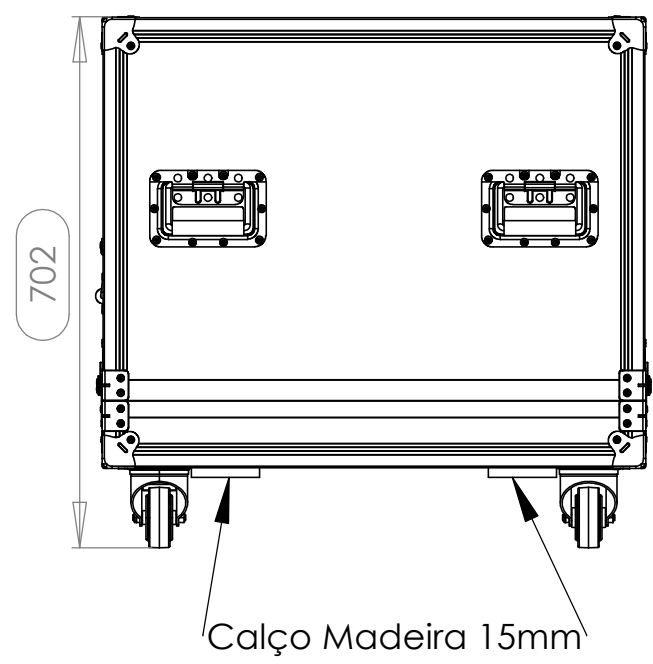
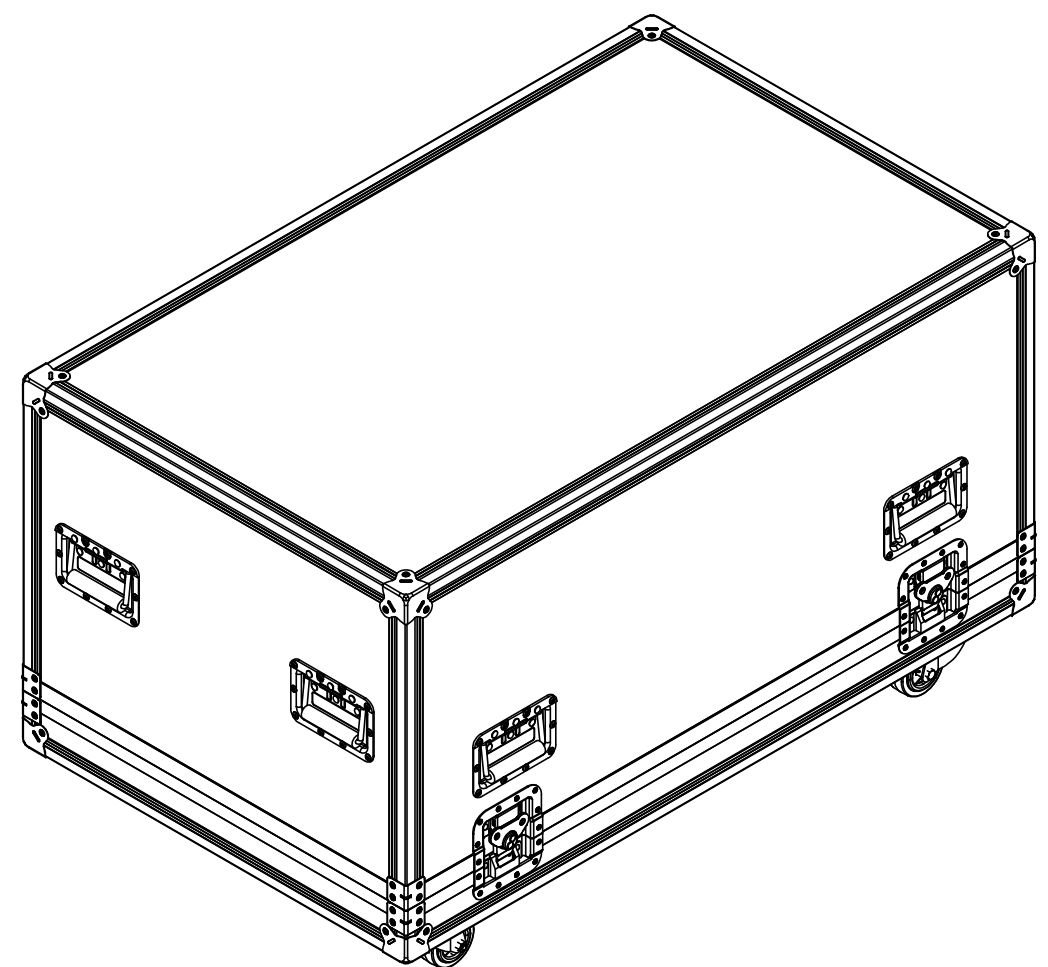

Hardware		
Qty	Ref.	Description
8	40403	Large corner bracket f. 35mm case angle
4	172531	Large butterfly V3 with 'push-back' function
6	34082	Recessed sprung handle medium model
2	RODA.80T	Swivel castor Ø80 mm with brake
2	RODA.80	Swivel castor Ø80 mm without brake
8	4004	Case corner zinc plated

Material	Name	Date	 santosom PROFESSIONAL CASES
Drawn by	DanielLopes	10-12-2014	
Reference	816.164		
This drawing must not be copied or disclosed without consent of the owner	Scale	units in mm	general tolerance
	1:10	DO NOT SCALE	±0.8mm
1st Angle projection	FC, PM-MASTER		2014085-1, RODAS