

Internal Dimensions		
Width	Depth	Height
2206	356	556
Weight	Approx. 33 Kg	
Wall Thickness	7mm	

SECTION B-B

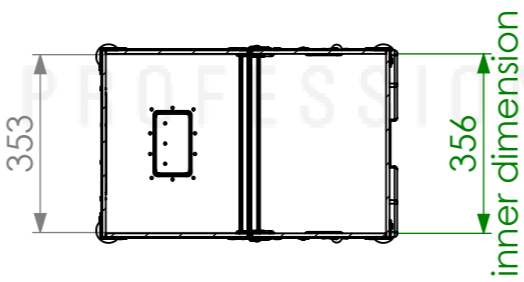

SECTION A-A

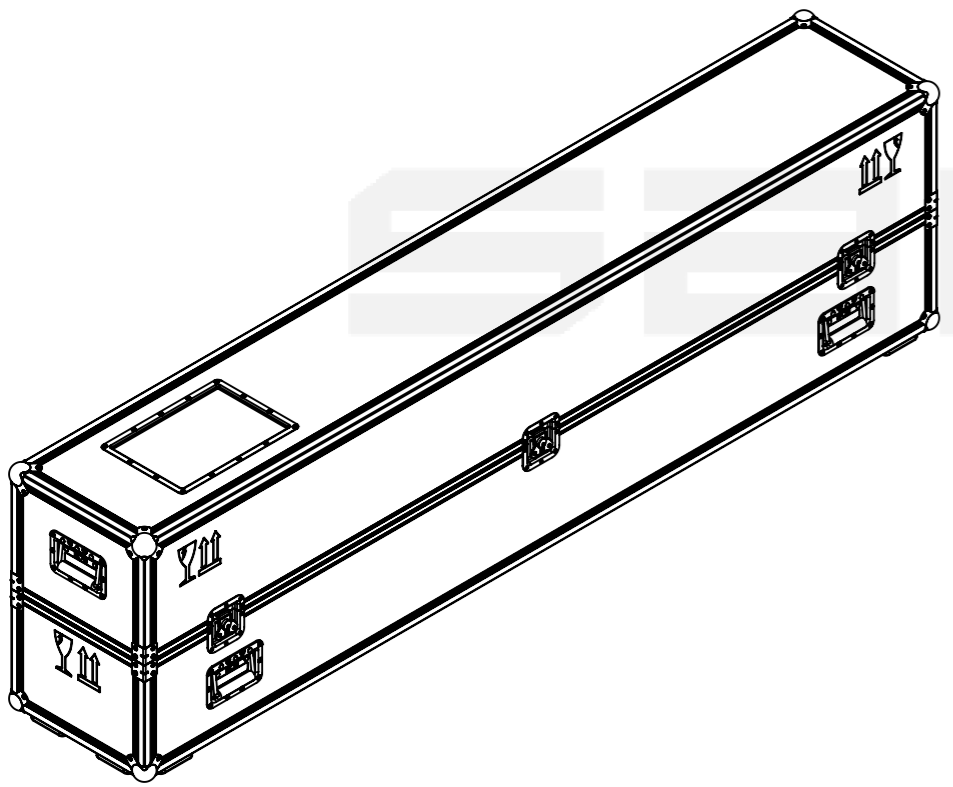
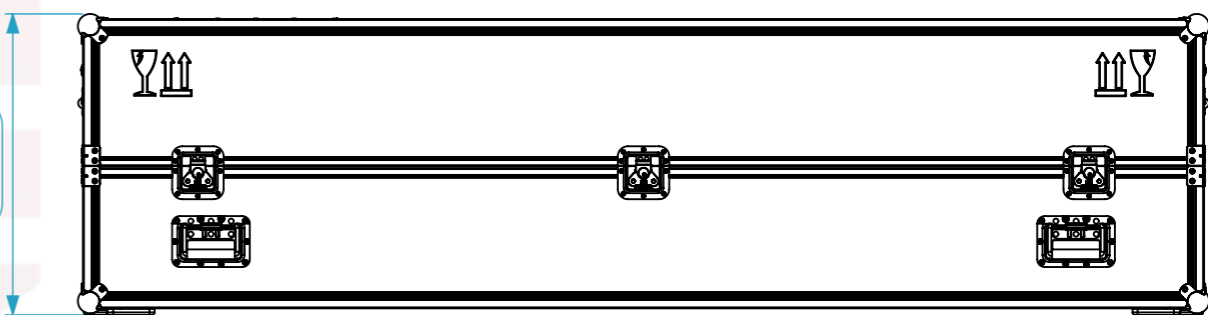
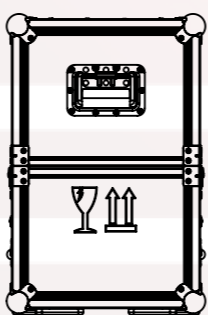
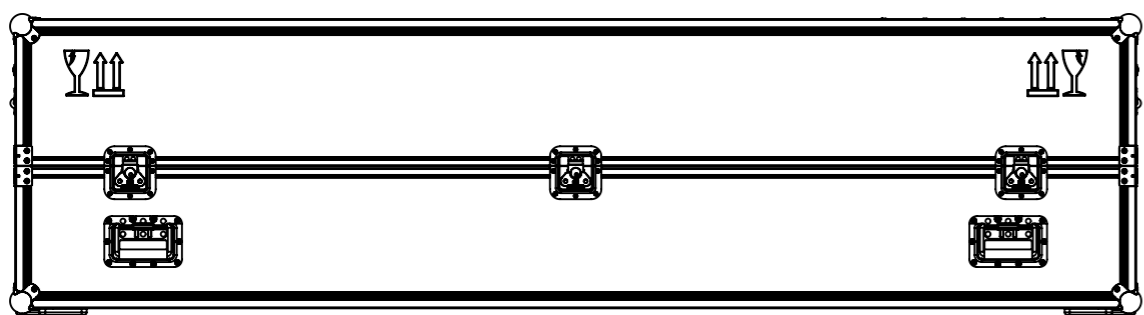
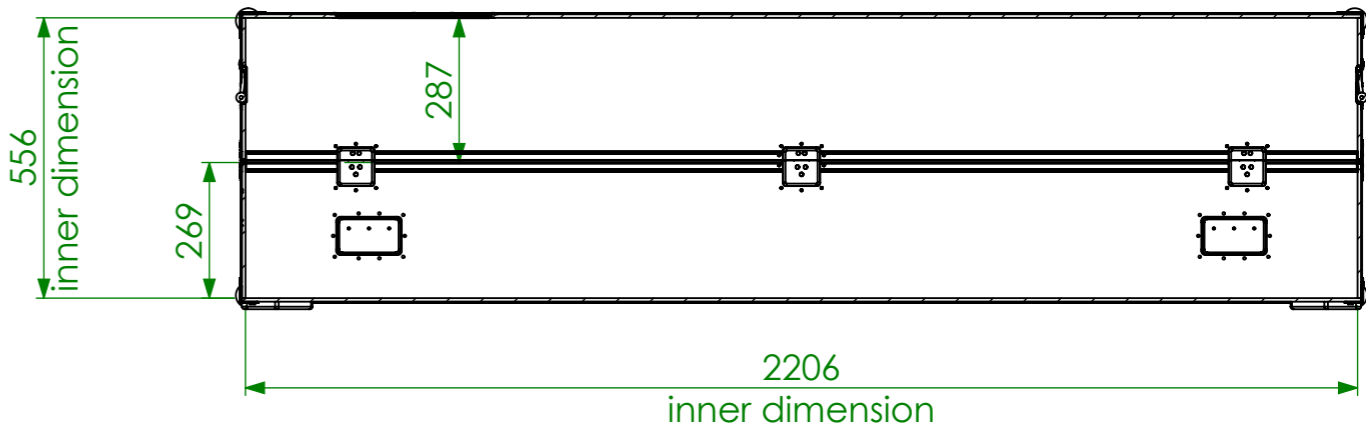
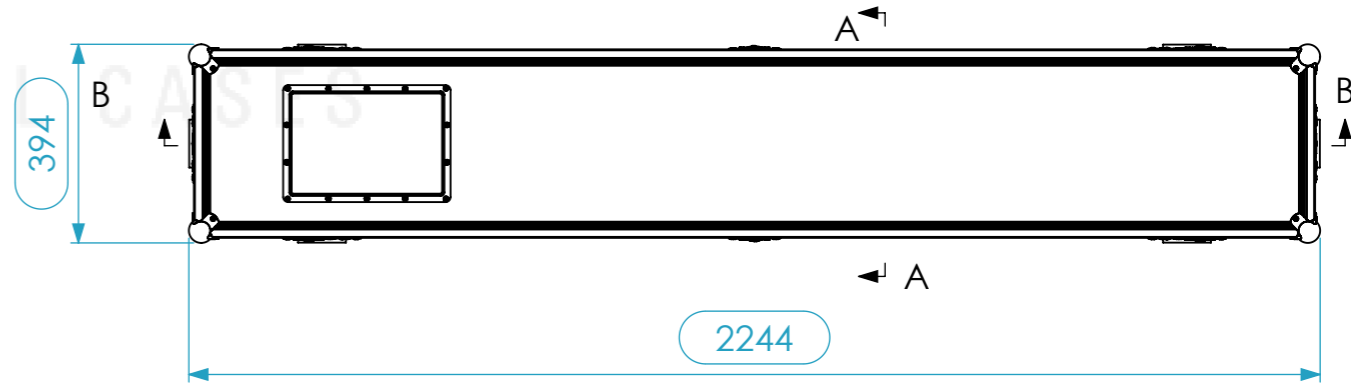

Hardware		
Qty	Ref.	Description
8	40403	Large corner bracket f. 35mm case angle
6	17290S	Key lockable medium Butterfly special
6	34082	Recessed Sprung Handle Medium
8	4120	Heavy duty ball corner, zinc plated
1	88005D	Dish for 88005 Tour Label

This drawing must not be copied or disclosed without consent of the owner

Drawn by	Name	Date
CarlaSilva	CarlaSilva	25/01/2018
Reference	816.1811	
Scale	units in mm	general tolerance
1:15	DO NOT SCALE	0.8mm
1st Angle projection	FC, SUBMERSIVEL XP3 2206X356X556	

