

Interior dimensions		
Width	Depth	Height
2050	750	920
Weight	Approx. 85 Kg	
Wall Thickness	9mm	

REVISIONS				
ZONE	REV.	DESCRIPTION	DATE	APPROVED
-	-	Final Drawing	27/02/2014	Daniel Lopes

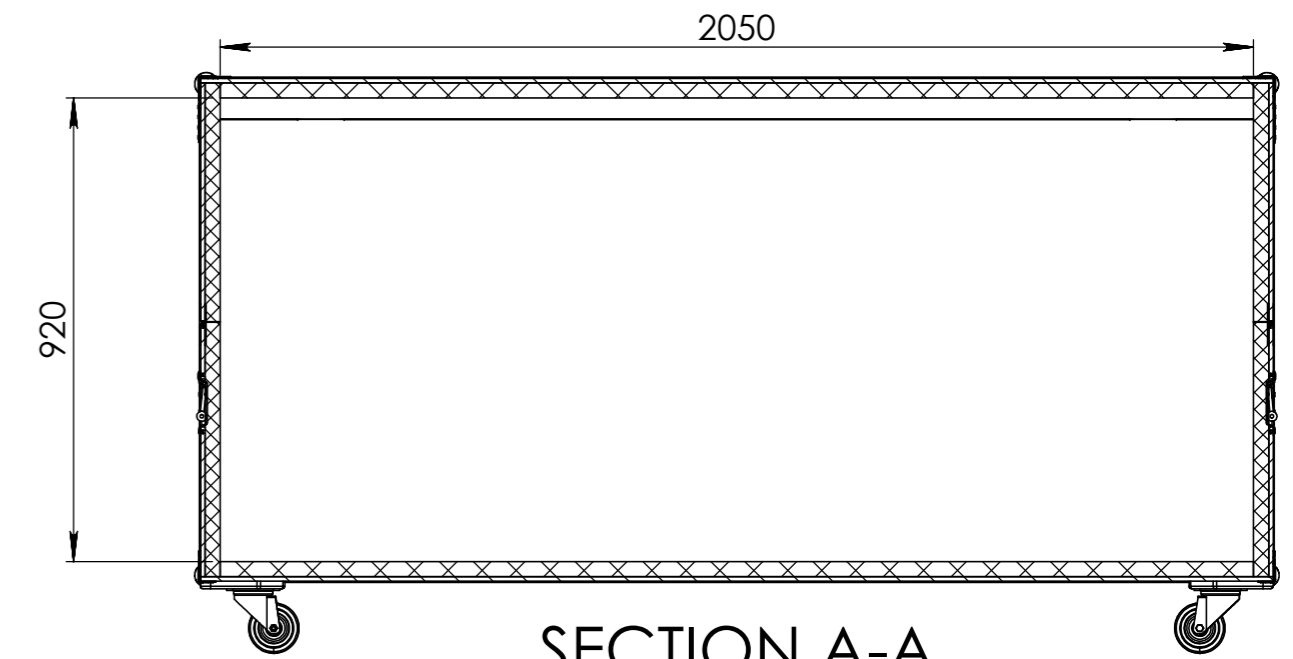

SECTION A-A

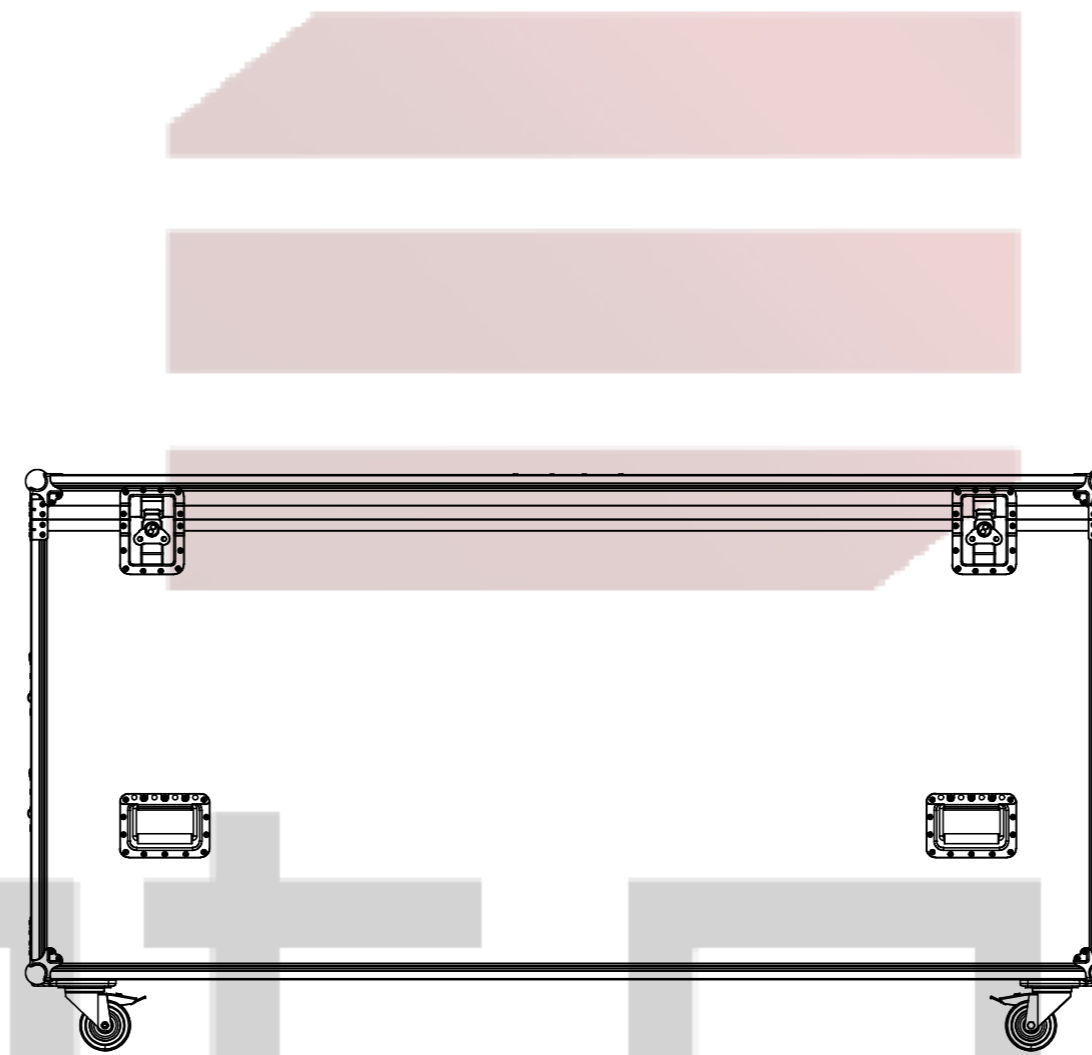
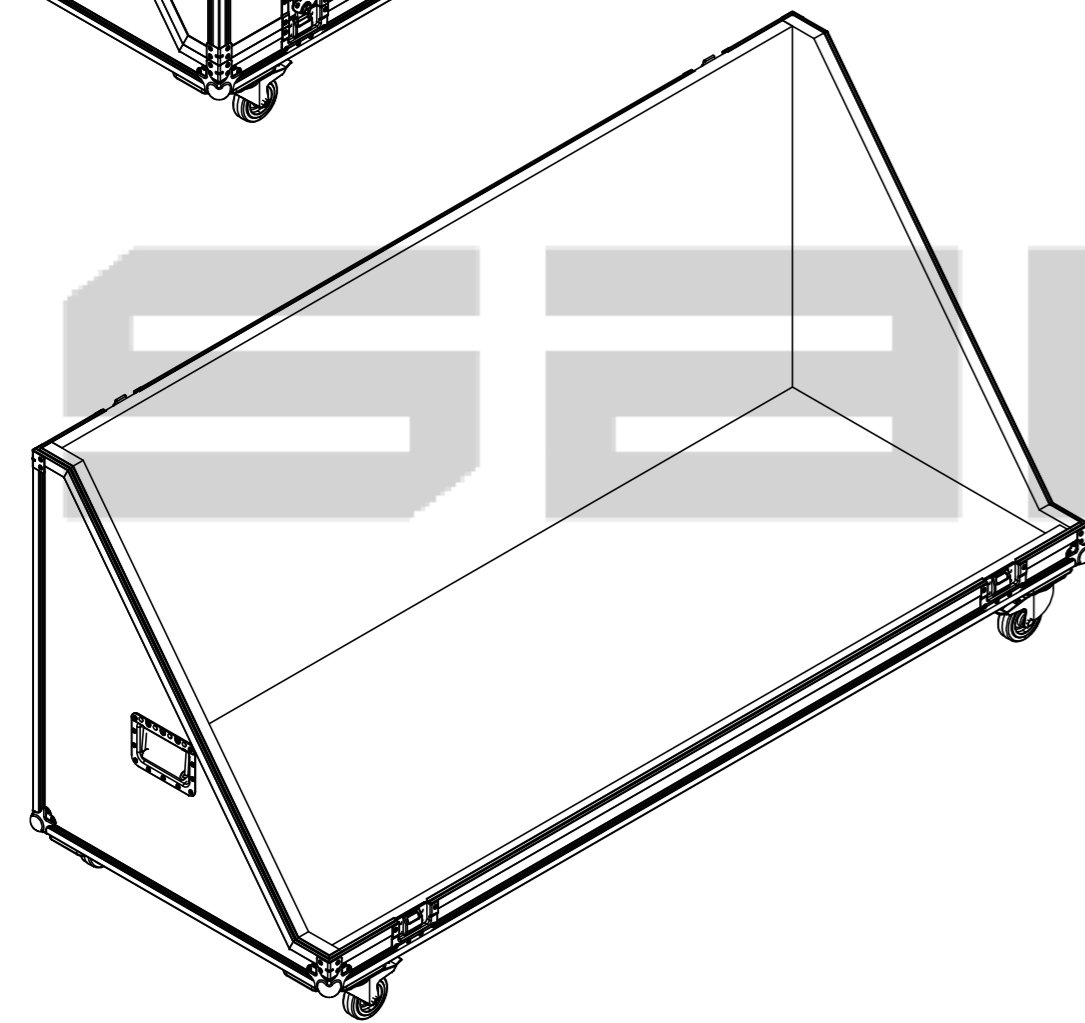
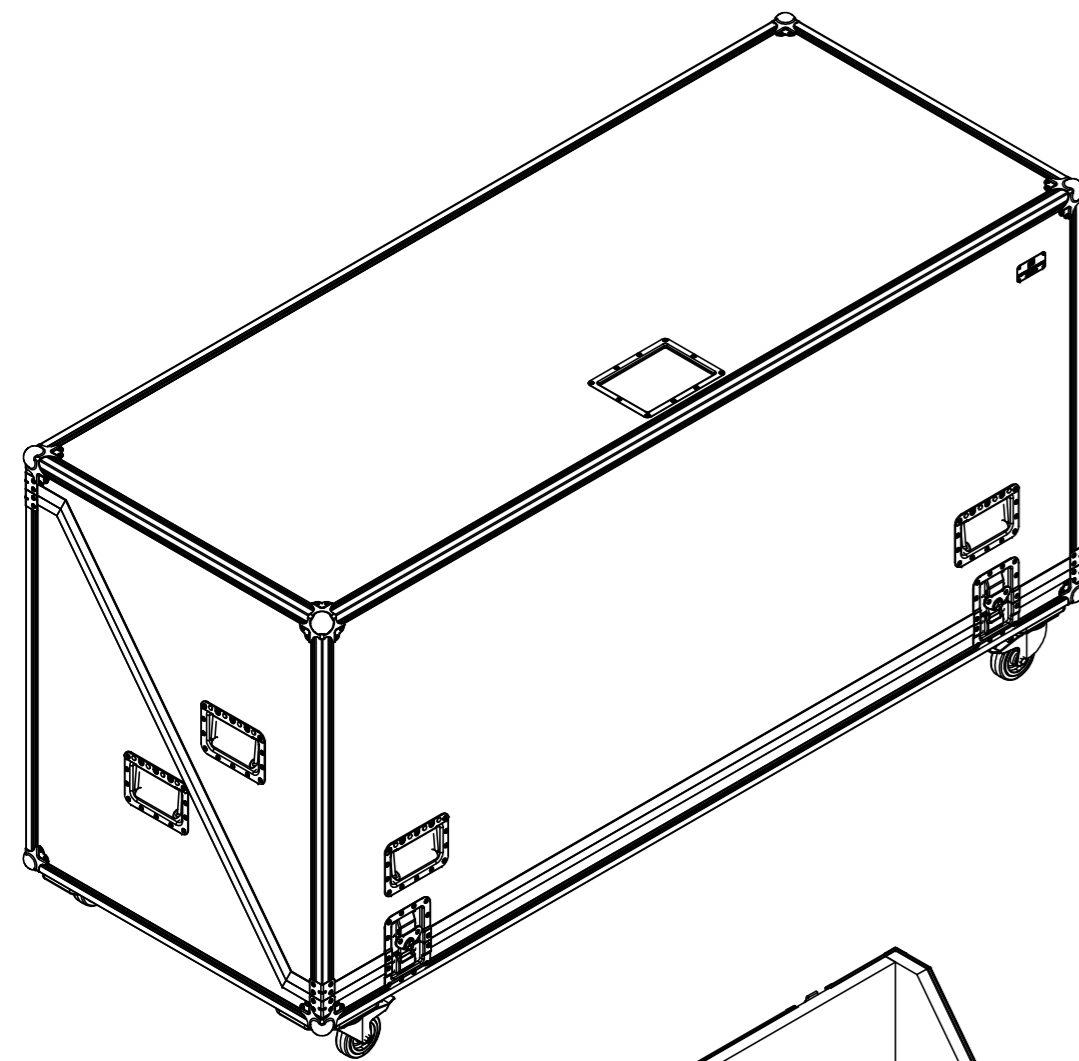
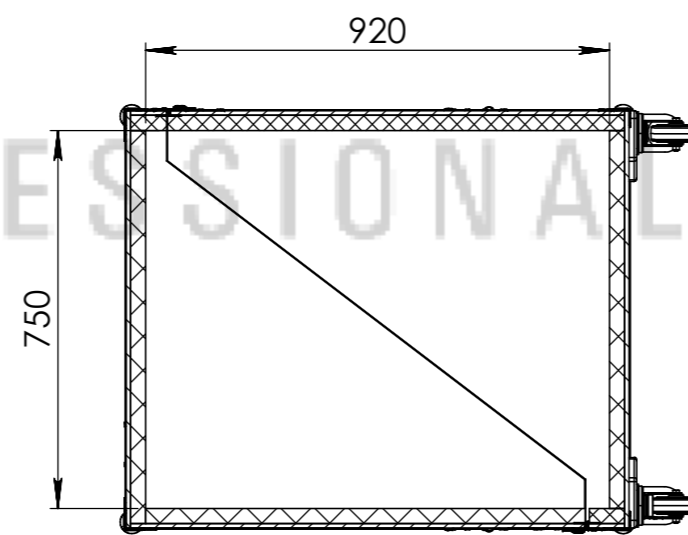
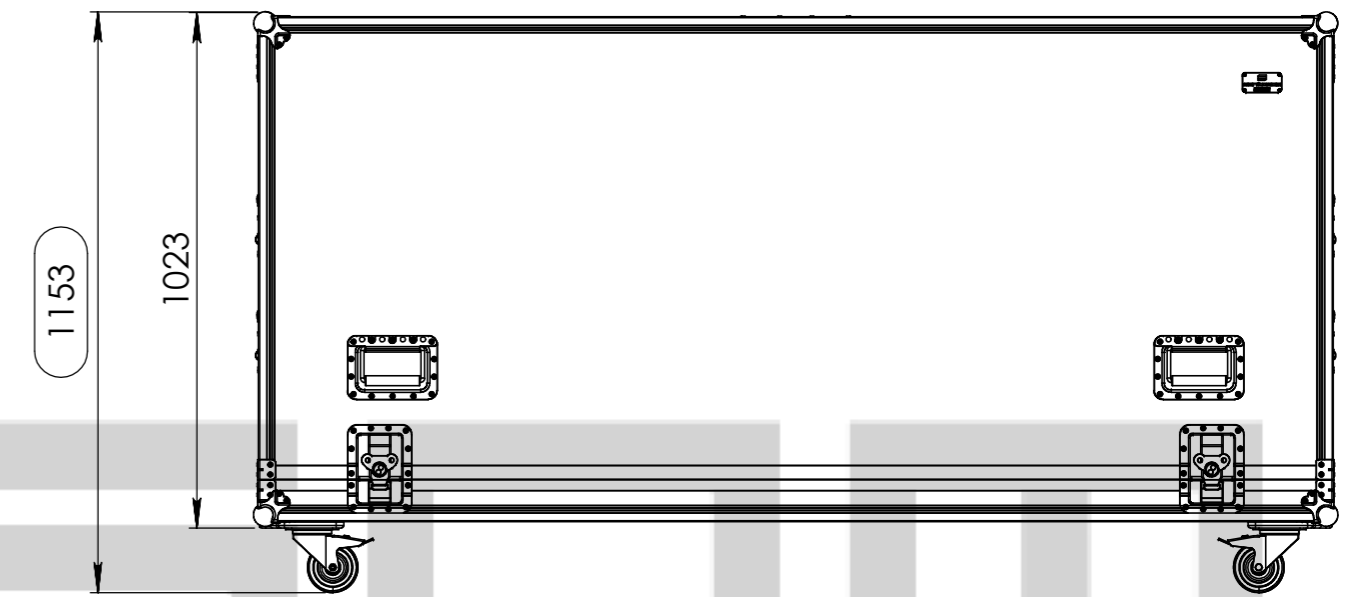

SECTION B-B

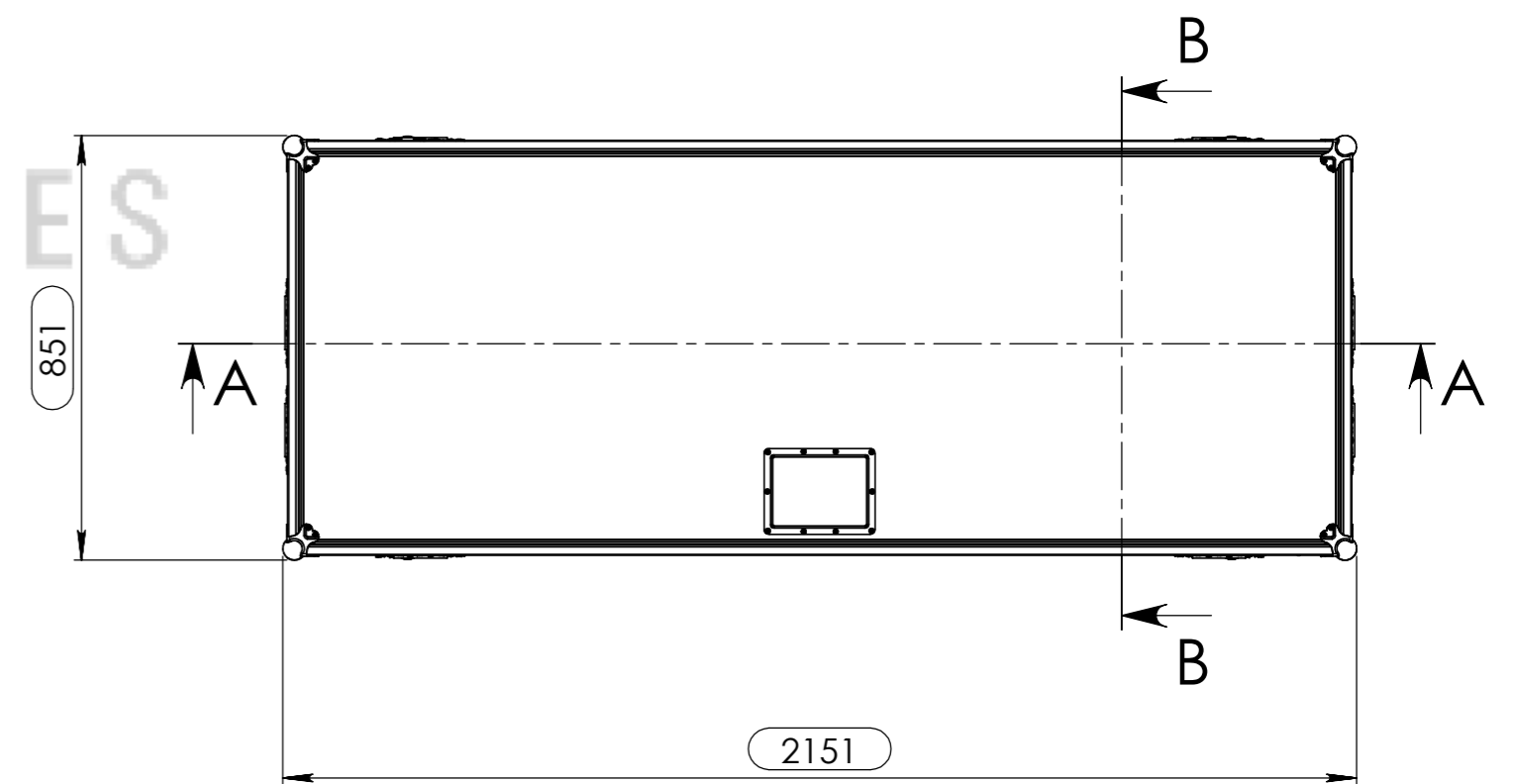

Hardware		
Qty	Ref.	Description
8	410429	Heavy Duty Ball Corner
8	40403	Large corner bracket f. 35mm case angle
1	88001D	Dish for 88001 Tour Label
8	34085	Large, heavy duty, recessed sprung handle
4	172511COMP	Large AH butterfly with 'push-back' function in 14mm dish
2	RODA.100T	Swivel castor Ø100mm with brake
2	RODA.100	Swivel castor Ø100 mm

Drawn by	Name	Date
Daniel Lopes	Daniel Lopes	27-02-2014
Reference	651.118R	
Scale	1:15	general tolerance ±0.8mm
FC. Transport BAR 2050x750x920mm., rodas		

This drawing must not be copied or disclosed without consent of the owner