

Interior dimensions		
Width	Depth	Height
561	666	875
Weight		Approx. 59 Kg
Wall Thickness		10mm

Revision Table				
Index	Rev.	Description	Date	Draw
-	0	Final Drawing	06/06/2013	Daniel Lopes

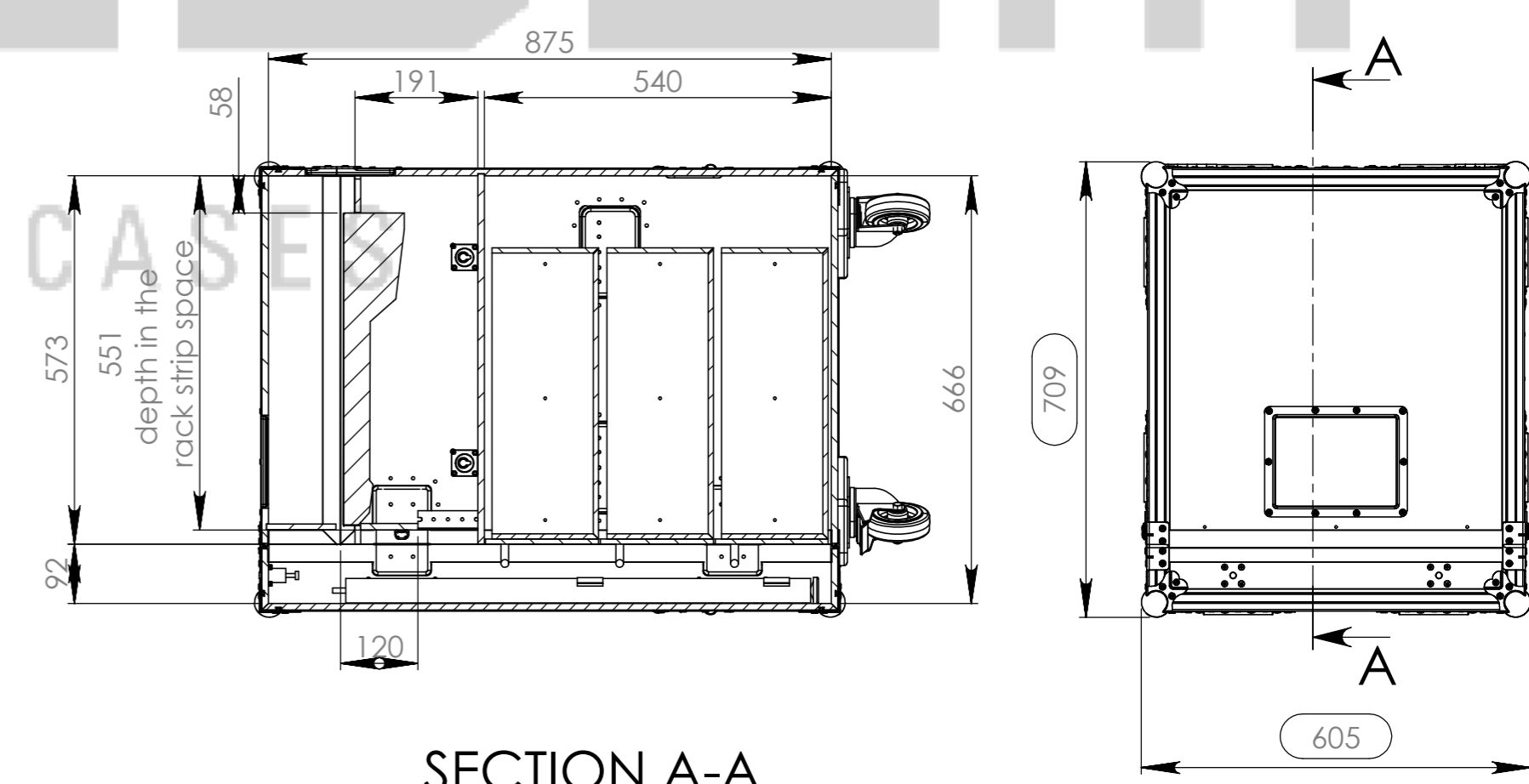
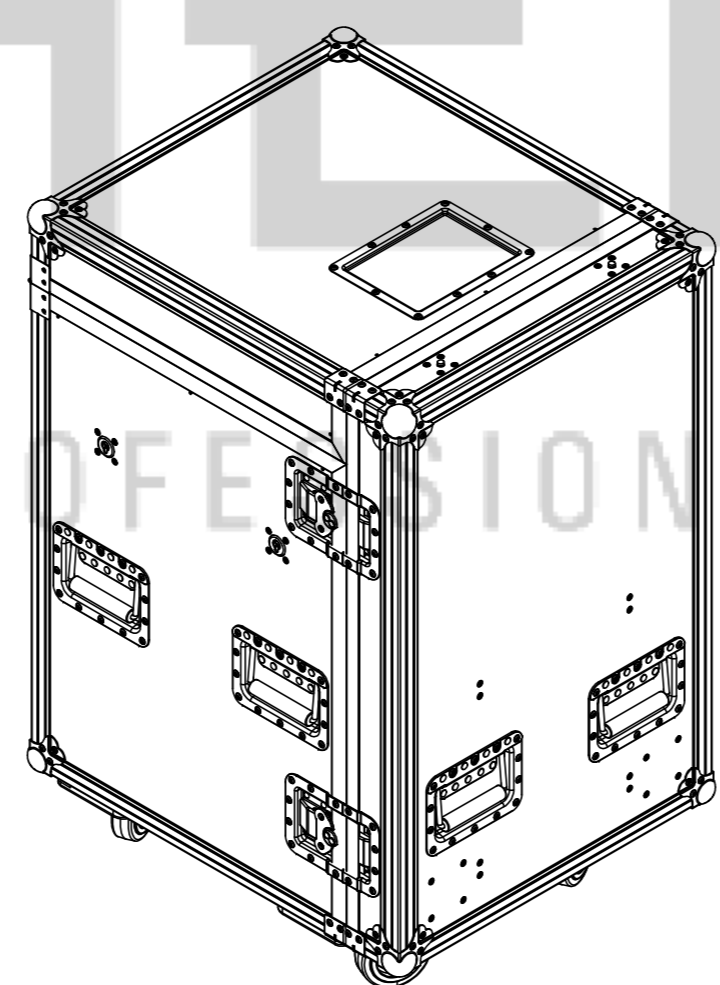
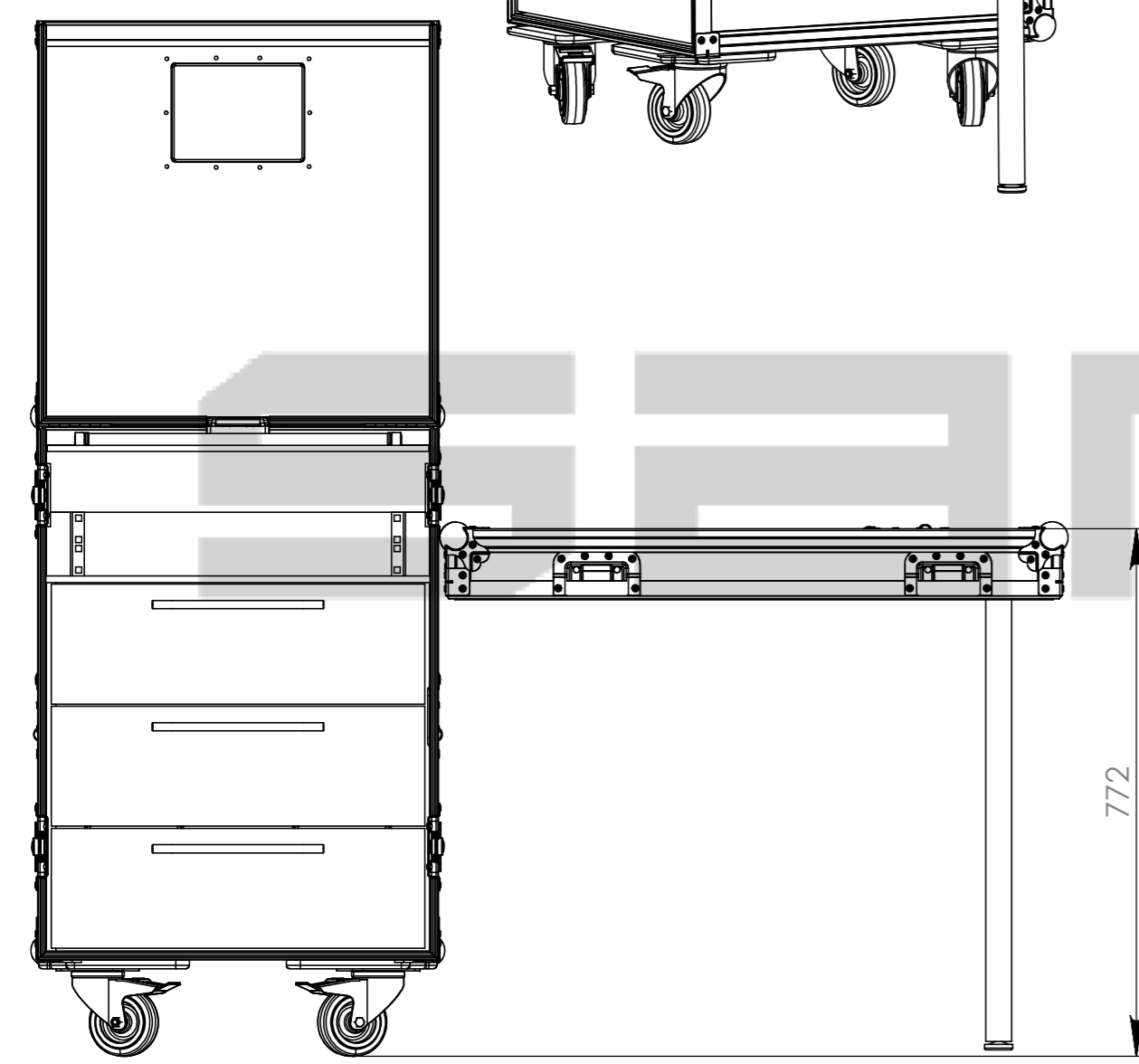
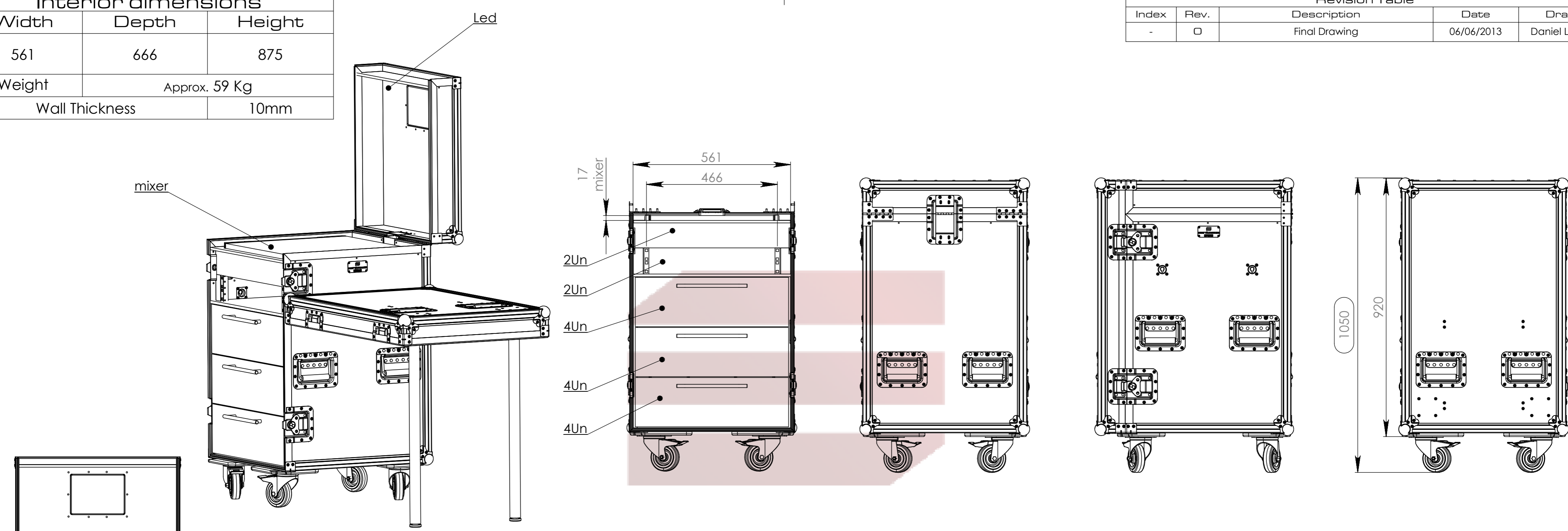

SECTION A-A

Hardware		
Qty	Ref.	Description
8	40403	Large corner bracket f. 35mm case angle
8	34085	Large, heavy duty, recessed sprung handle
2	RODA.100T	Swivel castor Ø100 mm with brake
2	RODA.100	Swivel castor Ø100 mm
4	172511COMP	Large AH butterfly with 'push-back' function in 14mm dish
8	410429	Ball Corner large three-leg cranked 35 mm 9 holes
2	DCR110	110MM hinge shot
1	270735	Large lidstay cranked / hinge
1	88001D	Dish for 88001 Tour Label

Drawn by	Daniel Lopes	Name	Daniel Lopes	Date	07-06-2013
Reference	651.101	Scale	1:10	general tolerance	±0.3mm
This drawing must not be copied or disclosed without consent of the owner		1st Angle projection	DO NOT SCALE	RC, RSF, MIXER+ 4 GAVET	2U+4U+4U+4U, RODAS