

| Interior dimensions | | |
|---------------------|---------------|--------|
| Width | Depth | Height |
| 1640 | 190 | 240 |
| Weight | Approx. 48 Kg | |
| Wall Thickness | | 10mm |

| REVISIONS | | | | |
|-----------|------|---------------|------------|------------------|
| ZONE | REV. | DESCRIPTION | DATE | APPROVED |
| | 0 | Final Drawing | 08-01-2015 | Carlos Rodrigues |

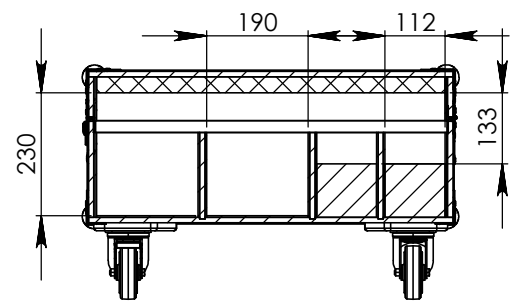

SECTION B-B

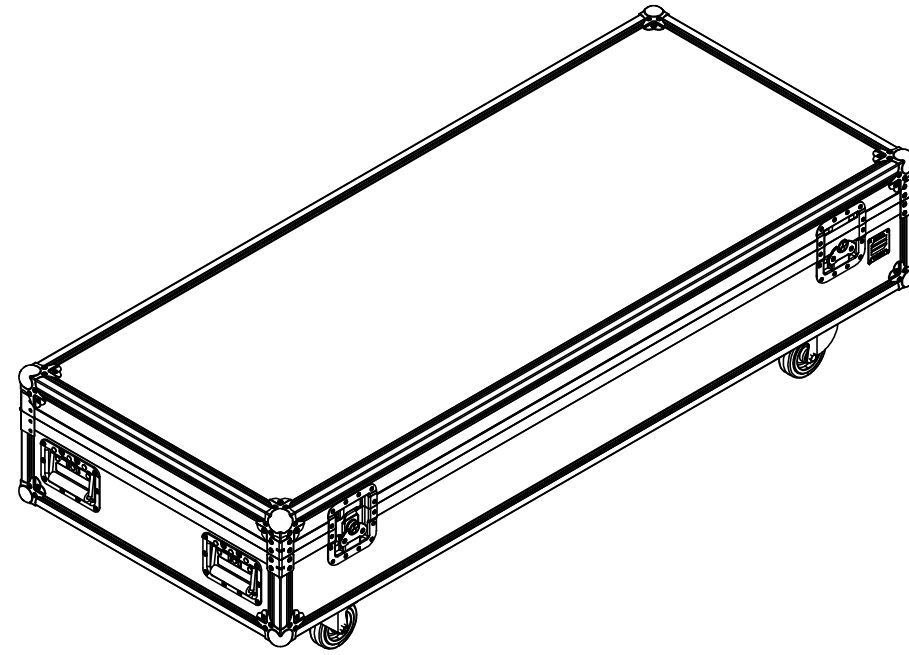
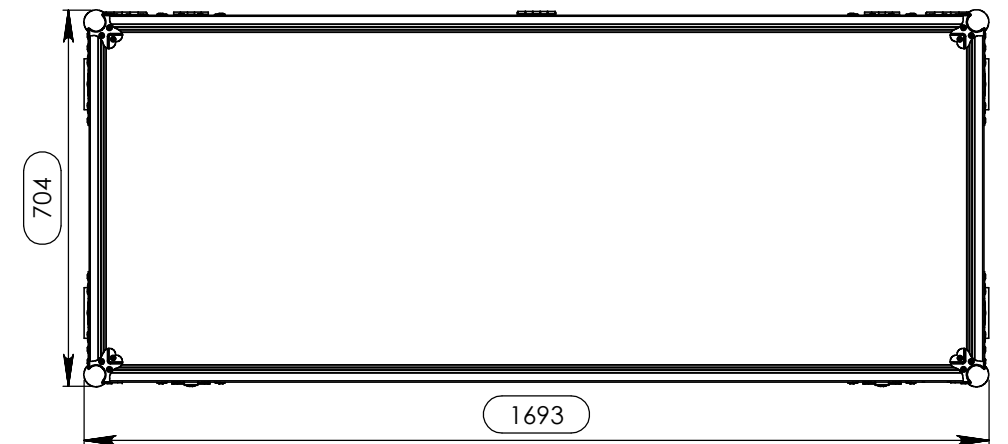
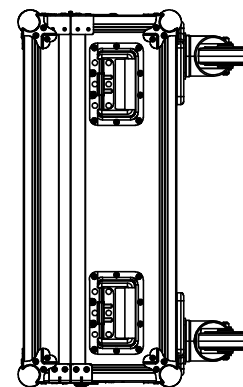
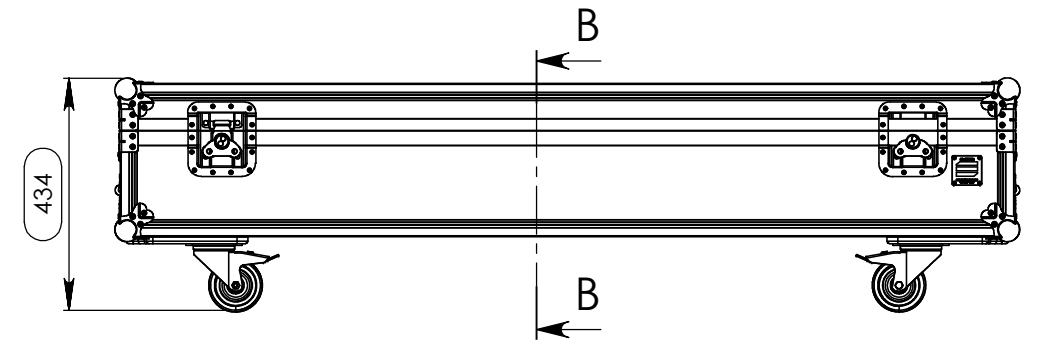
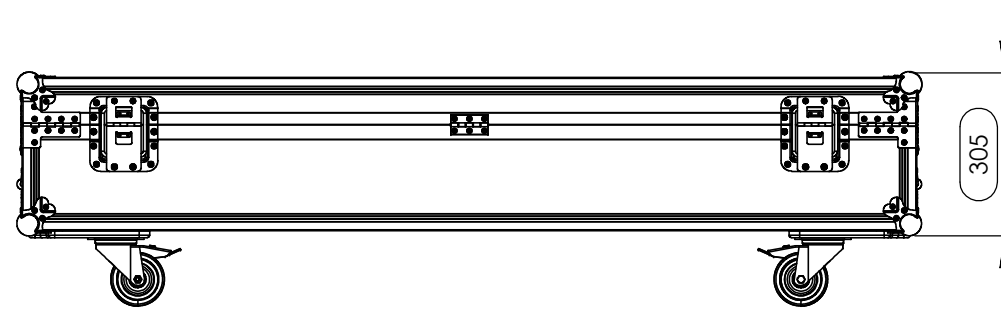

| Hardware | | |
|----------|------------|---|
| Qty | Ref. | Description |
| 4 | 34082 | Recessed sprung handle medium model |
| 2 | 270736 | Short recessed lidstay cranked |
| 2 | 172531 | Large butterfly V3 with 'push-back' function |
| 1 | CHAPA.1000 | Identification Plate |
| 8 | 410429 | Ball Corner large three-leg cranked 35 mm 9 holes |
| 2 | Rodas.1000 | |
| 2 | Rodas.1000 | |
| 2 | RODA.100T | Swivel castor Ø100mm with brake |
| 2 | RODA.100 | Swivel castor Ø100 mm |
| 1 | 2602 | Medium duty butt hinge z./p. |
| 2 | DCR110 | 110MM hinge shot |
| 4 | 40403 | Large corner bracket f. 35mm case angle |

This drawing must not be copied or disclosed without consent of the owner

| | | |
|----------------------|---------------------------------------|------------|
| Drawn by | Name | Date |
| projects | | 08-01-2015 |
| Reference | 567.101R | |
| Scale | 1:10 | |
| 1st Angle projection | FC: 2 TRIPES + 2 BARRAS DIMMER, RODAS | |

