

Equipment		ImSim	
Width	Depth	Height	
1970	780	1250	
Internal Dimensions			
Width	Depth	Height	
906	2206	1545	
Weight	Approx. 266 Kg		
Wall Thickness	10mm		

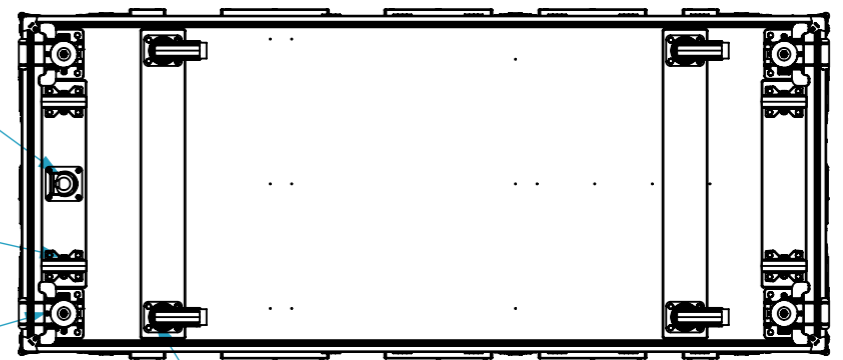
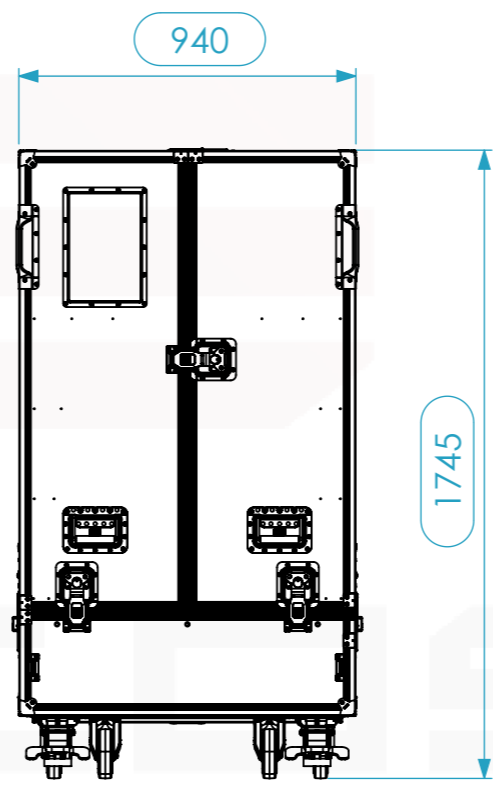
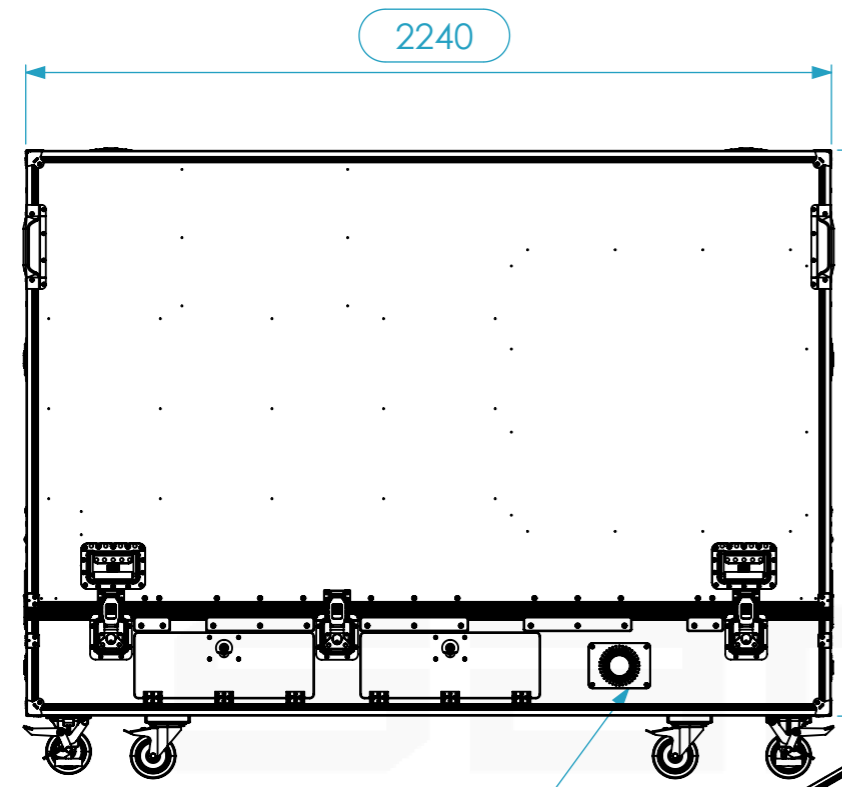

Roping Eye

Fixed wheels

Foot Locks

Swivel Wheels with brake

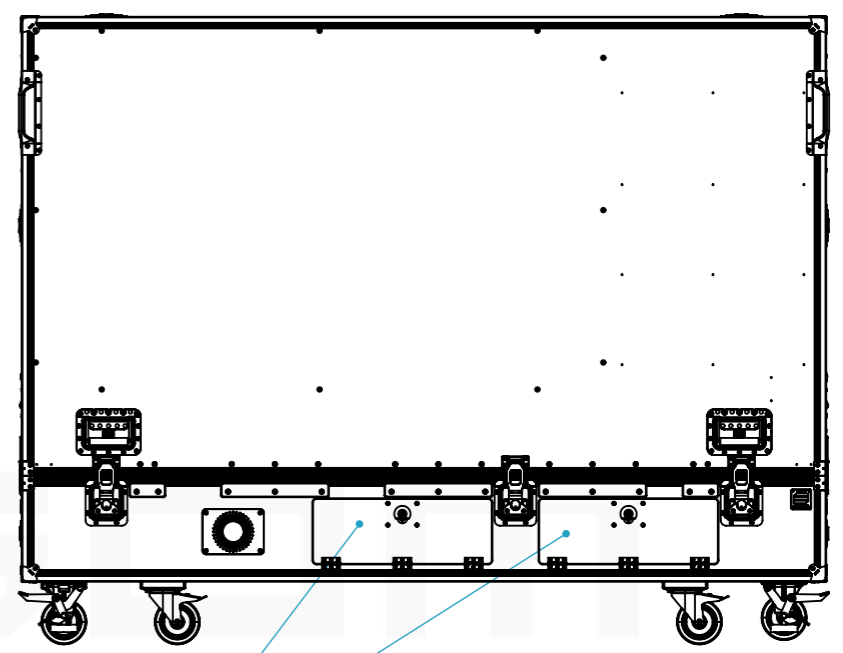

Two inner compartments with lockable hinged doors

Ventilation grid

Label Holder

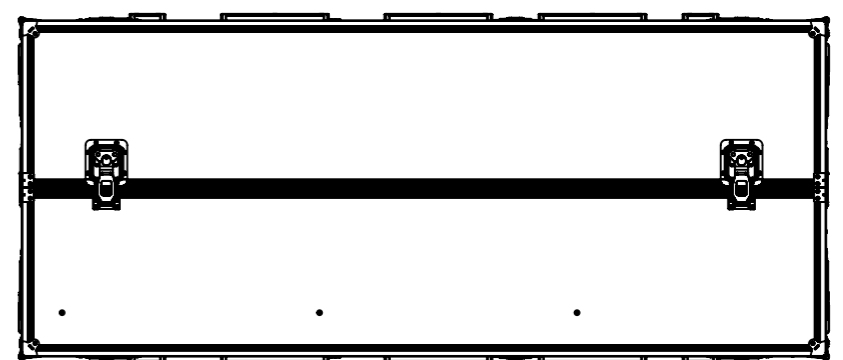
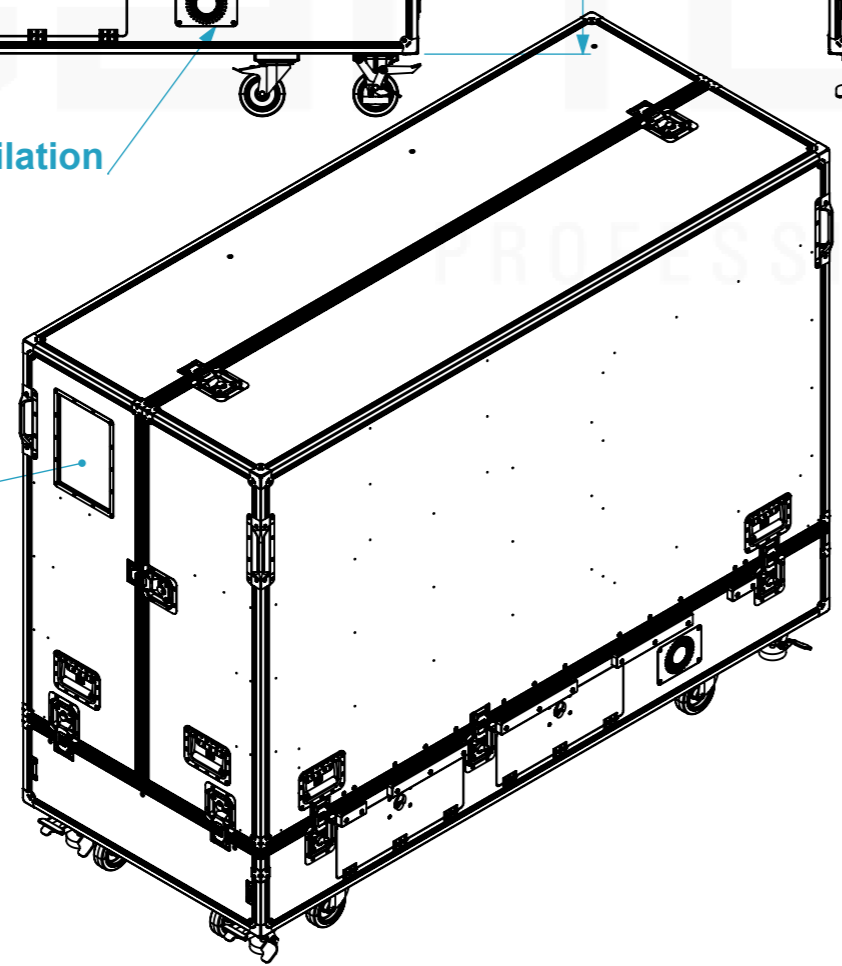

Drawn by	Name	Date
alexandre	alexandre	20-07-2018
Reference	2872.003	
Scale	units in mm	general tolerance
1:21	DO NOT SCALE	0.8mm
FC PRO-3, SIMULADOR CONDUÇÃO V3		



This drawing must not be copied or disclosed without consent of the owner

1st Angle projection

A3

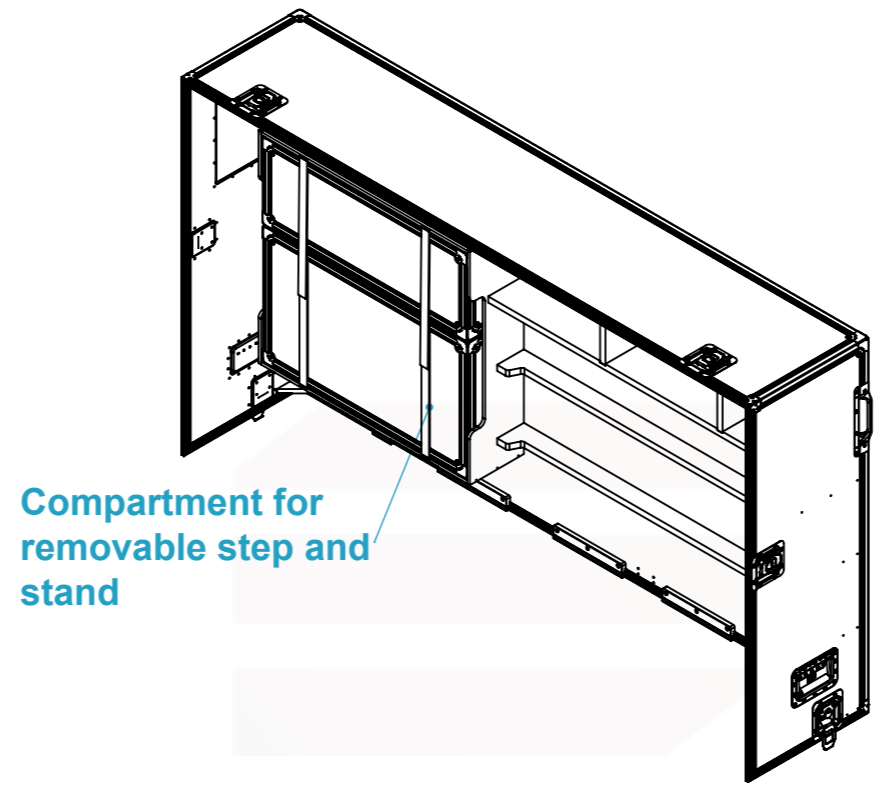
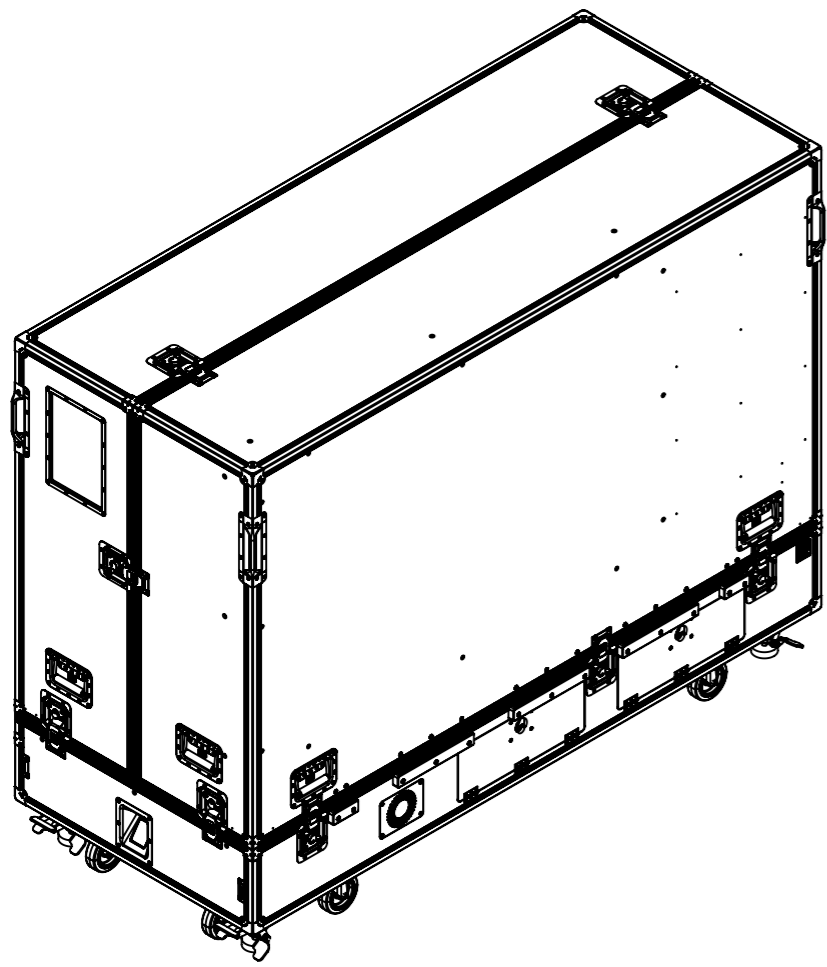

Compartment for removable step and stand

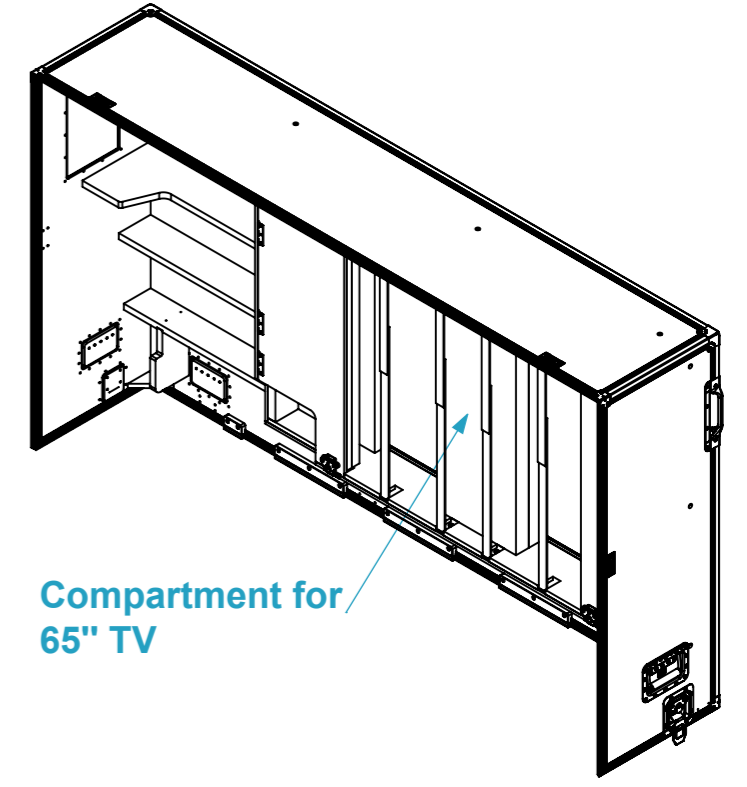

Compartment for 65" TV

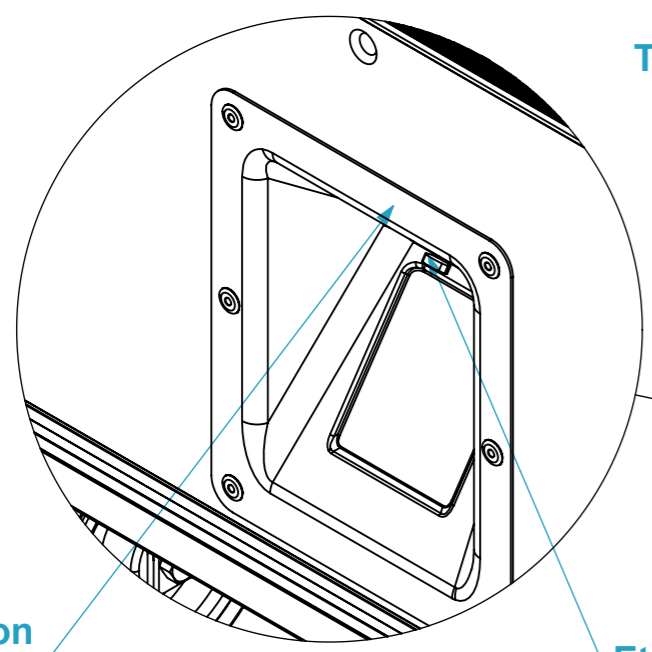

PowerCon Connector (Power In)

Ethernet Connector

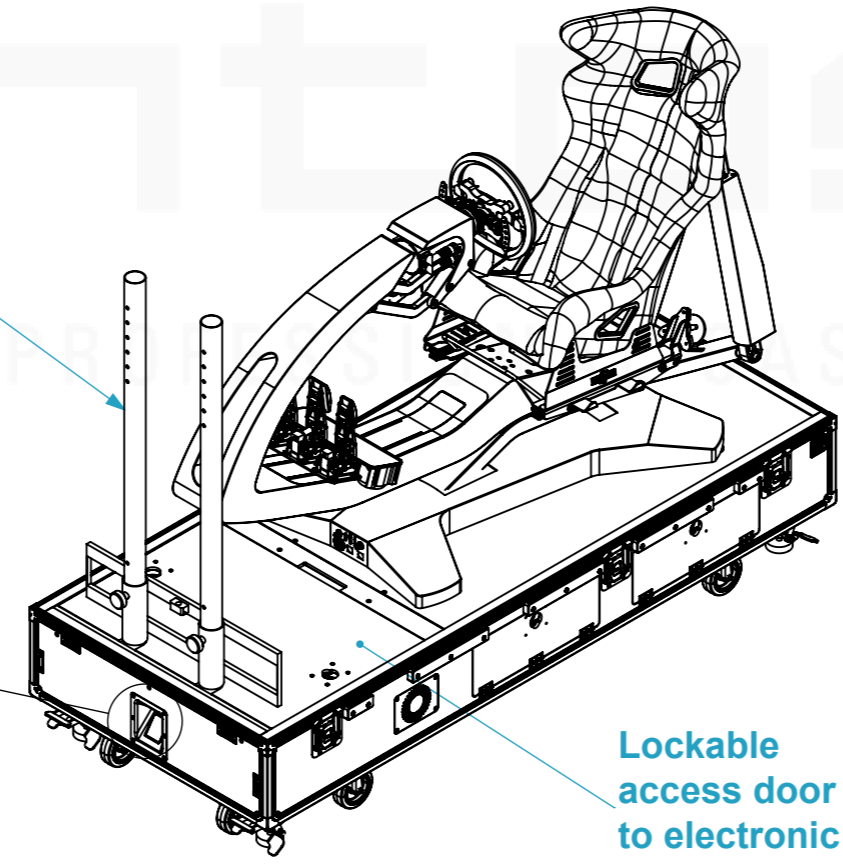

TV Stand

Lockable access door to electronic housing

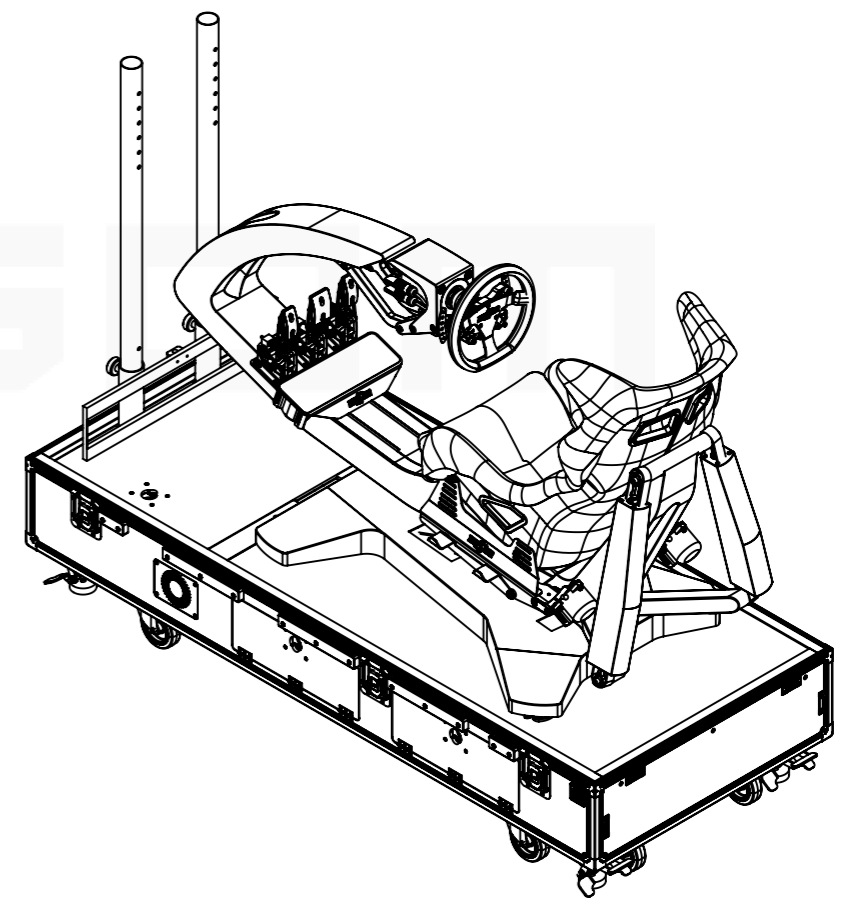

Drawn by	Name	Date
alexandre	alexandre	20-07-2018
Reference	2872.003	
Scale	units in mm	general tolerance
1:21	DO NOT SCALE	0.8mm
FC PRO-3, SIMULADOR CONDUÇÃO V3		



This drawing must not be copied or disclosed without consent of the owner



A3

Stand Configurations:

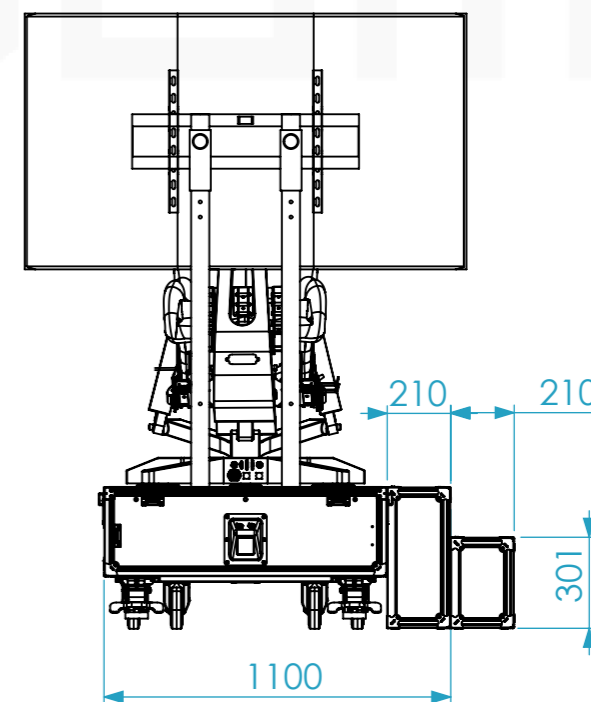
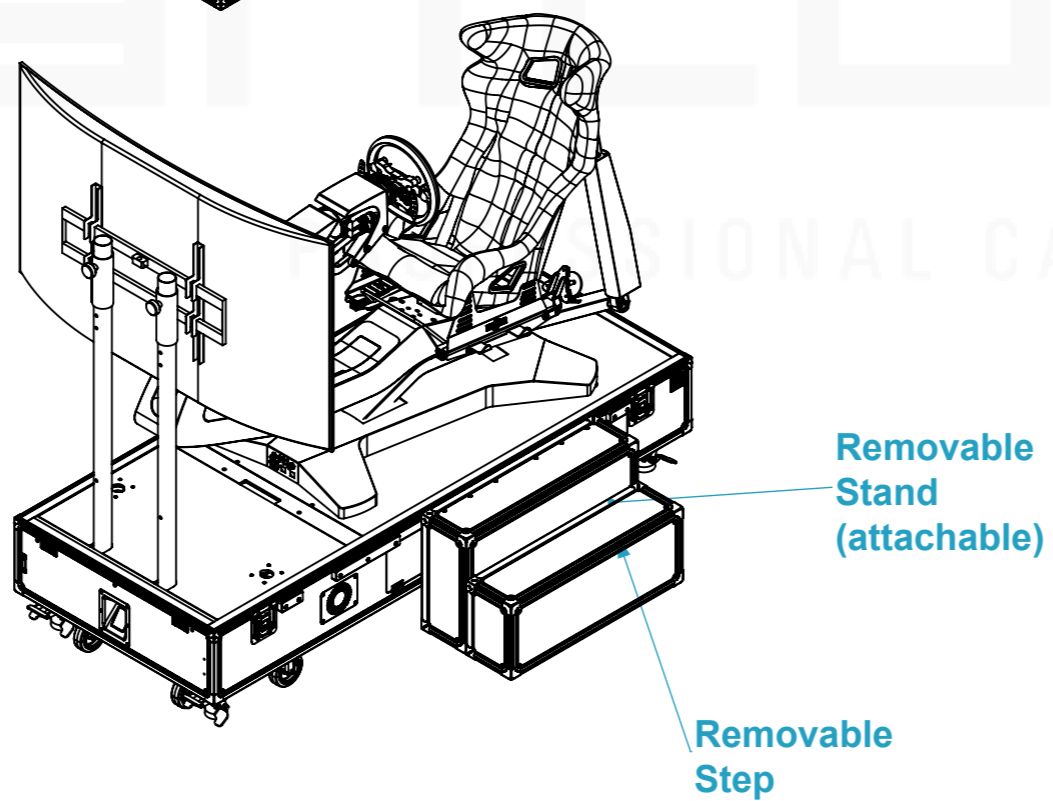
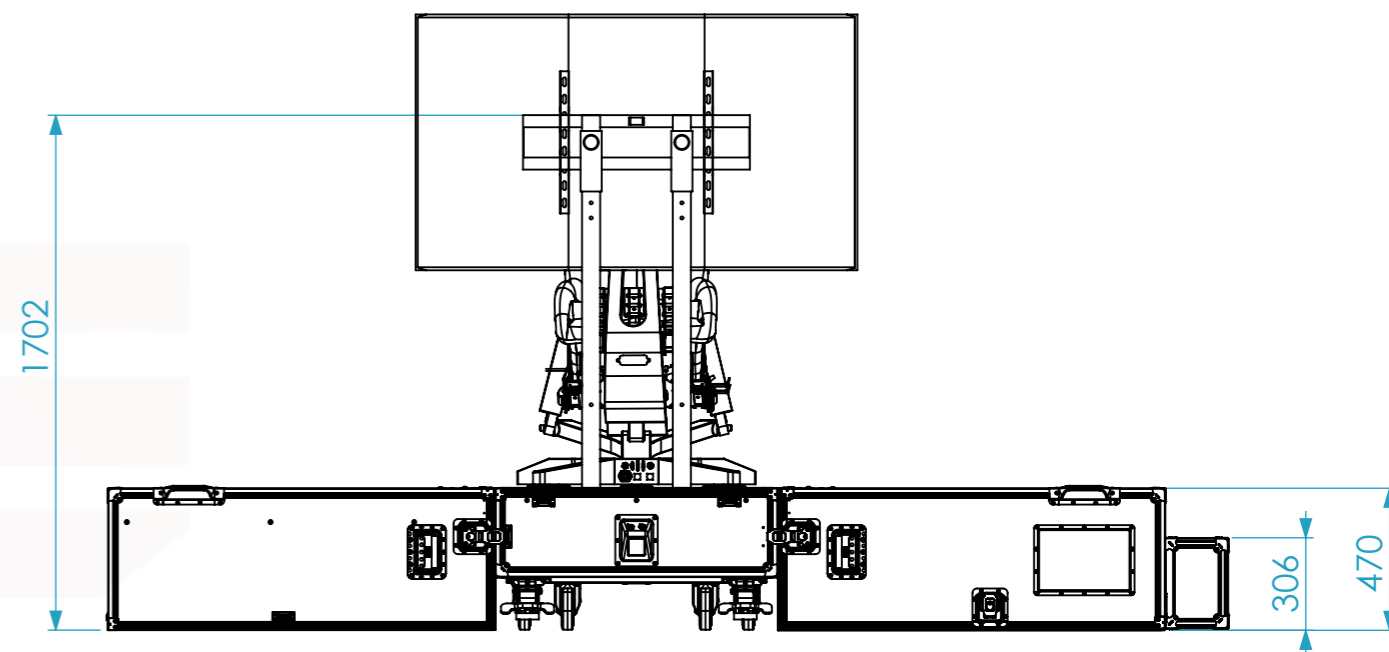
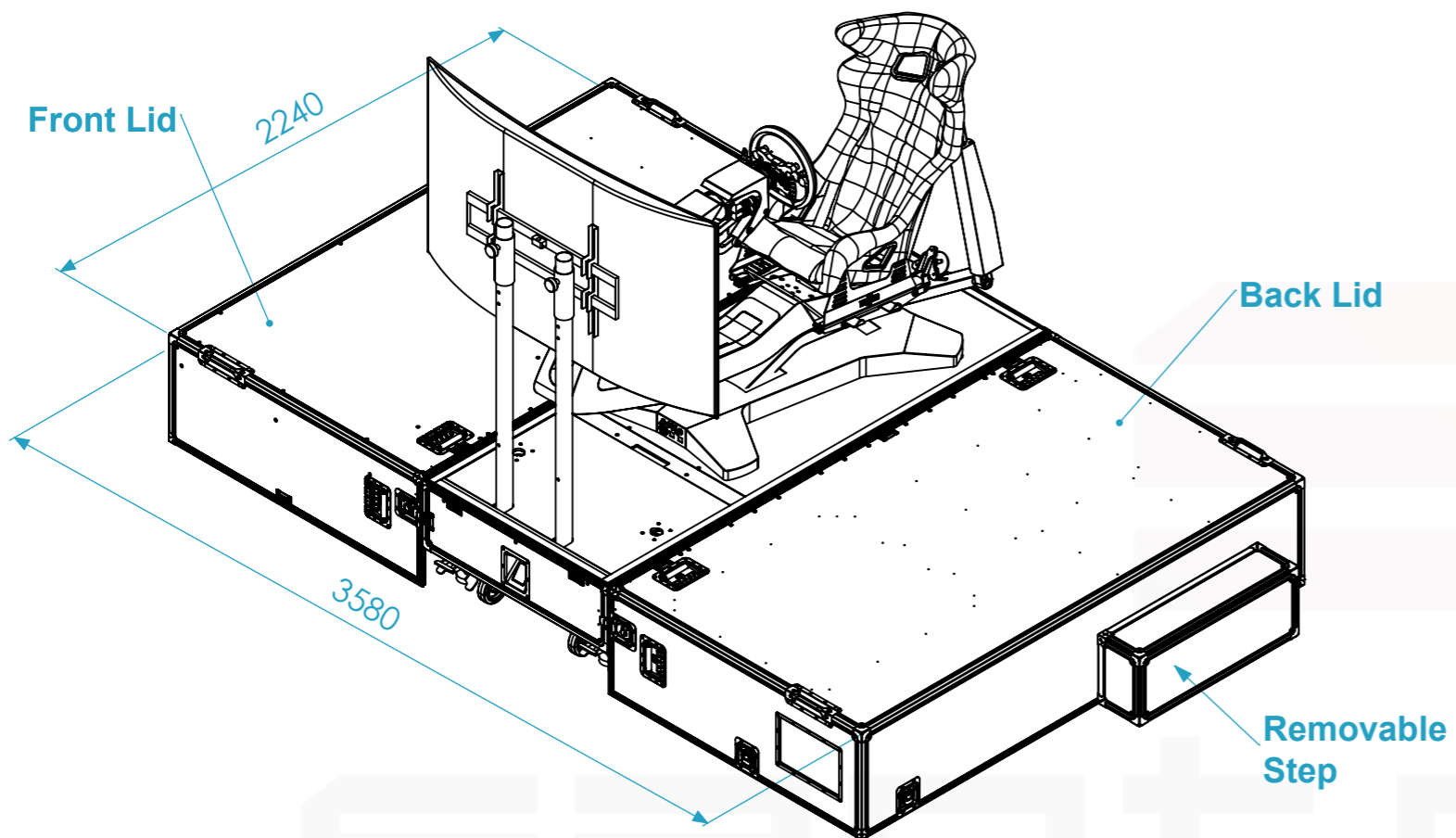

Drawn by	Name	Date
alexandre	alexandre	20-07-2018
Reference	2872.003	
Scale	units in mm	general tolerance
1:25	DO NOT SCALE	0.8mm
FC PRO-3, SIMULADOR CONDUÇÃO V3		



This drawing must not be copied or disclosed without consent of the owner



A3